

TABLE OF CONTENTS

4.1 PRELIMINARY DESIGN	4-5
4.1.1 GENERAL.....	4-5
4.1.1.1 Roadway Geometrics.....	4-5
4.1.1.1.1 Alignment and Grade.....	4-5
4.1.1.1.2 Typical Section and Roadway Width.....	4-5
4.1.1.1.3 Clear Zone.....	4-7
4.1.1.2 Bridge Geometrics.....	4-7
4.1.1.2.1 Span Length.....	4-7
4.1.1.2.2 Abutment Type.....	4-8
4.1.1.2.3 Bent/Pier Type.....	4-8
4.1.1.2.4 Approach/Sleeper Slabs.....	4-14
4.1.2 LAYOUT CRITERIA.....	4-17
4.1.2.1 Drainage Structure Sites.....	4-17
4.1.2.1.1 Box Culvert Sites.....	4-17
4.1.2.1.2 Bridge Sites.....	4-25
4.1.2.1.3 Reinforced Concrete Pipe Sites.....	4-26
4.1.2.1.4 Miscellaneous Drainage Sites.....	4-26
4.1.2.2 Grade Separation Structures.....	4-27
4.2 FINAL DESIGN	4-30
4.2.1 GENERAL.....	4-30
4.2.1.1 QC/QA.....	4-30
4.2.1.1.1 Quality Control.....	4-30
4.2.1.1.2 Quality Assurance.....	4-31
4.2.1.1.3 QA/QC Reviews.....	4-31
4.2.1.1.4 General.....	4-33
4.2.1.2 Load Rating.....	4-34
4.2.1.3 Design Method.....	4-34
4.2.1.4 Load Modifiers.....	4-35
4.2.1.5 Distribution of Flexural Reinforcement.....	4-35
4.2.2 LOADS.....	4-35
4.2.2.1 Dead Loads.....	4-36
4.2.2.2 Live Load.....	4-36
4.2.2.3 Seismic Load.....	4-36
4.2.2.4 Soil Load.....	4-36
4.2.2.5 Thermal Forces.....	4-36
4.2.2.6 Ice and Debris Load.....	4-37
4.2.3 MATERIALS.....	4-37
4.2.4 BOX CULVERTS.....	4-38
4.2.4.1 Barrel Design.....	4-38
4.2.4.2 Inlet and Outlet Design.....	4-42
4.2.4.2.1 Wing Wall Design.....	4-42
4.2.4.2.2 Drop Inlet or Outlet.....	4-43
4.2.4.2.3 Non-monolithic Aprons.....	4-43
4.2.4.3 Construction Joints.....	4-44
4.2.5 BRIDGE SUPERSTRUCTURES.....	4-44
4.2.5.1 General.....	4-44
4.2.5.1.1 Deck Slabs on Girders.....	4-44
4.2.5.1.2 Bearings.....	4-46

4.2.5.1.3 Expansion Devices.....	4-48
4.2.5.1.4 Sidewalks/Shared Use Paths	4-49
4.2.5.1.5 Railings.....	4-50
4.2.5.1.6 Deck Drains.....	4-51
4.2.5.1.7 Utilities and Lighting.....	4-52
4.2.5.1.8 Sign Supports.....	4-52
4.2.5.1.9 Stream Gaging Stations	4-53
4.2.5.2 Concrete Slab Superstructures	4-53
4.2.5.3 Prestressed Girder Superstructures	4-56
4.2.5.4 Steel Girder Superstructures	4-64
4.2.6 SUBSTRUCTURES.....	4-69
4.2.6.1 General.....	4-69
4.2.6.1.1 Foundations	4-69
4.2.6.1.2 Frost.....	4-69
4.2.6.1.3 Scour	4-69
4.2.6.1.4 Piling	4-70
4.2.6.1.5 Drilled Shafts.....	4-71
4.2.6.1.6 Spread Footings	4-72
4.2.6.2 Abutments	4-72
4.2.6.2.1 Stub Integral Abutments:.....	4-72
4.2.6.2.2 Sill Type Expansion Abutments:	4-75
4.2.6.2.3 Vertical Abutments:.....	4-76
4.2.6.3 Bents and Piers.....	4-76
4.2.6.3.1 Frame Bents.....	4-76
4.2.6.3.2 Pile Bents.....	4-77
4.2.6.3.3 Pier Walls (Including Pier Walls with Cantilevers).....	4-78
4.2.6.3.4 Single Column Hammerhead Piers	4-78
4.2.7 MISCELLANEOUS STRUCTURES	4-79
4.2.7.1 Signal Pole and Luminaire Footings.....	4-79
4.2.7.2 Sign Supports	4-80
4.2.7.3 Structural Plate High Profile Arch Structures.....	4-81
4.2.7.4 Retaining Walls.....	4-81
4.2.7.5 Stream Stabilization.....	4-82
4.2.7.5.1 Riprap.....	4-82
4.2.7.5.2 Gabions and/or Rock and Wire Baskets.....	4-82
4.2.7.5.3 Miscellaneous Stream Stabilization Structures	4-82

LIST OF TABLES AND FIGURES

Figure 4.1.1 - 1 Bridge Alignment for Horizontal Curve.....	4-6
Figure 4.1.1 - 2 Three Column Bent Continuous Concrete Bridge.....	4-9
Figure 4.1.1 - 3 Two Column Bent Continuous Concrete Bridge.....	4-10
Figure 4.1.1 - 4 Three Column Bent Girder Bridge.....	4-10
Figure 4.1.1 - 5 Two Column Bent Girder Bridge.....	4-11
Figure 4.1.1 - 6 Hammerhead Pier Wall Girder Bridge.....	4-11
Figure 4.1.1 - 7 Alternate Two Column Bent Girder Bridge.....	4-12
Figure 4.1.1 - 8 Steel Pipe Bent Continuous Concrete Bridge.....	4-12
Figure 4.1.1 - 9 Pier Wall on Drilled Shafts Continuous Concrete Bridge.....	4-13
Figure 4.1.1 - 10 Hat Type Sleeper Slab.....	4-14
Figure 4.1.1 - 11 L Type Sleeper Slab.....	4-15
Figure 4.1.1 - 12 Flat Type Sleeper Slab.....	4-15
Figure 4.1.1 - 13 Flat Type Sleeper Slab.....	4-16
Figure 4.1.2 - 1 Box Culvert Cell Layout.....	4-17
Figure 4.1.2 - 2 Cast in Place Box Culvert Length Layout.....	4-17
Figure 4.1.2 - 3 Precast Box Culvert Length Layout.....	4-18
Figure 4.1.2 - 4 Inslope Parapet Intersection (Cast in Place).....	4-19
Figure 4.1.2 - 5 Box Culvert Fill Height Designation.....	4-20
Figure 4.1.2 - 6 RHF and LHF Box Culvert Skew.....	4-20
Figure 4.1.2 - 7 Cast in Place Box Culvert Wing Flare Diagram.....	4-21
Figure 4.1.2 - 8 Cast in Place Box Culvert Working Points.....	4-22
Figure 4.1.2 - 9 Precast Box Culvert Inlet/Inslope Intersection.....	4-23
Figure 4.1.2 - 10 Structure Over State Highway.....	4-26
Figure 4.1.2 - 11 Structure Over Rural Interstate Highway.....	4-27
Figure 4.1.2 - 12 Structure Over Urban Street.....	4-27
Figure 4.1.2 - 13 Structure Over Railroad.....	4-28
Figure 4.1.2 - 14 High Profile Plate Arch Over Railroad.....	4-28
Figure 4.2.1 - 1 General Title Block Requirements.....	4-Error! Bookmark not defined.
Figure 4.2.4 - 1 Construction Vehicle Configuration.....	4-38
Figure 4.2.4 - 2 Fillet and Optional Fillet Details.....	4-39
Figure 4.2.4 - 3 Inlet Parapet Bevel Detail.....	4-40
Figure 4.2.4 - 4 Wingwall Design Height.....	4-40
Figure 4.2.4 - 5 Box Culvert Construction Joints.....	4-42
Figure 4.2.5 - 1 Steel Girder Fixed Rocker Bearing.....	4-46
Figure 4.2.5 - 2 Steel Girder Expansion Rocker Bearing.....	4-46
Figure 4.2.5 - 3 Single Slope Concrete Bridge Rail.....	4-48
Figure 4.2.5 - 4 Single Slope Concrete Bridge Rail End Block.....	4-49
Figure 4.2.5 - 5 Open Concrete Bridge Rail.....	4-50
Figure 4.2.5 - 6 Deck Drain Detail Continuous Concrete Bridge.....	4-51
Figure 4.2.5 - 7 Deck Drain Details, Girder Bridge.....	4-52
Figure 4.2.5 - 8 Pole Support on Bridge Rail.....	4-53
Figure 4.2.5 - 9 Sign Support Bracket Shy Distance.....	4-53
Figure 4.2.5 - 10 Drop Panel Haunch Continuous Concrete Bridge.....	4-54
Figure 4.2.5 - 11 Parabolic Haunch Continuous Concrete Bridge.....	4-55

Figure 4.2.5 - 12 Flat Slab Continuous Concrete Bridge	4-55
Figure 4.2.5 - 13 36M Prestressed Girder Properties	4-59
Figure 4.2.5 - 14 45M Prestressed Girder Properties	4-59
Figure 4.2.5 - 15 54M Prestressed Girder Properties	4-60
Figure 4.2.5 - 16 63M Prestressed Girder Properties	4-60
Figure 4.2.5 - 17 72M Prestressed Girder Properties	4-61
Figure 4.2.5 - 18 81M Prestressed Girder Properties	4-62
Figure 4.2.5 - 19 Parabolic Haunch Steel Girder	4-63
Figure 4.2.5 - 20 Bolted Field Splice Detail.....	4-64
Figure 4.2.5 - 21 Direct Tension Indicator Details.....	4-65
Figure 4.2.5 - 22 Shear Stud Connection Detail.....	4-65
Figure 4.2.5 - 23 False Work Overhang Bracket.....	4-66
Figure 4.2.6 - 1 Integral Abutment Prestressed Girder Bridge.....	4-72
Figure 4.2.6 - 2 Integral Abutment Steel Girder Bridge.....	4-73
Figure 4.2.6 - 3 Integral Abutment Continuous Concrete Bridge	4-73
Figure 4.2.6 - 4 Sill Type Abutment for Girder Bridges	4-74
Figure 4.2.6 - 5 Spacers Required for Column Spiral Reinforcing	4-76
Table 4.2.1-1.....	4-35
Table 4.2.5-1.....	4-49

SECTION 4 DESIGN

4.1 Preliminary Design

4.1.1 General

Preliminary design consists of determining the best structure for a given site, including type, size and location (TS&L). The preliminary structure type should be chosen with regard to function, economics, and aesthetics in concert with data received from other offices as well as standard Office of Bridge Design (OBD) practices outlined in this document and should be as complete as possible prior to the TS&L inspection and final design.

4.1.1.1 Roadway Geometrics

4.1.1.1.1 Alignment and Grade

Roadway alignment and grade are provided through the Office of Roadway Design (ORD). Preliminary alignment and grade will be used to layout structures and OBD will provide input relative to any adjustments necessary for vertical clearance and/or hydraulic considerations for consideration in the final grade line and alignment.

Bridges on horizontally curved alignments are generally discouraged, but where required the roadway crown on the structure should be constant or planar due to finish machine capabilities. See **Figure 4.1.1-1** for layout of bridges on curved alignments.

A minimum longitudinal vertical gradient of 0.2 percent is desirable over bridge structures to facilitate roadway drainage. Care will be taken in crest vertical curves such that all surfaces of the structure meet the above requirement. If the minimum longitudinal slope cannot be achieved additional hydraulic analysis of the drainage on the structure will be required.

4.1.1.1.2 Typical Section and Roadway Width

Typical grading sections are provided through the ORD. Typical surfacing sections are provided through the Office of Materials and Surfacing (OMS). Structures will be designed to match the typical section and finished roadway width provided.

Box culvert structures are designed to fit the typical grading section. In cases of low fill conditions where minimum clear zone requirements control structure length, the typical section is modified to reflect the flatter inslope required to fit the fill to the structure.

Bridge structures are built to the full finished roadway width (design lanes plus shoulders). In urban areas with curb and gutter an additional width of bridge deck is constructed to match the gutter pan section and align the face of the bridge rail or barrier curb with the face of the curb section.

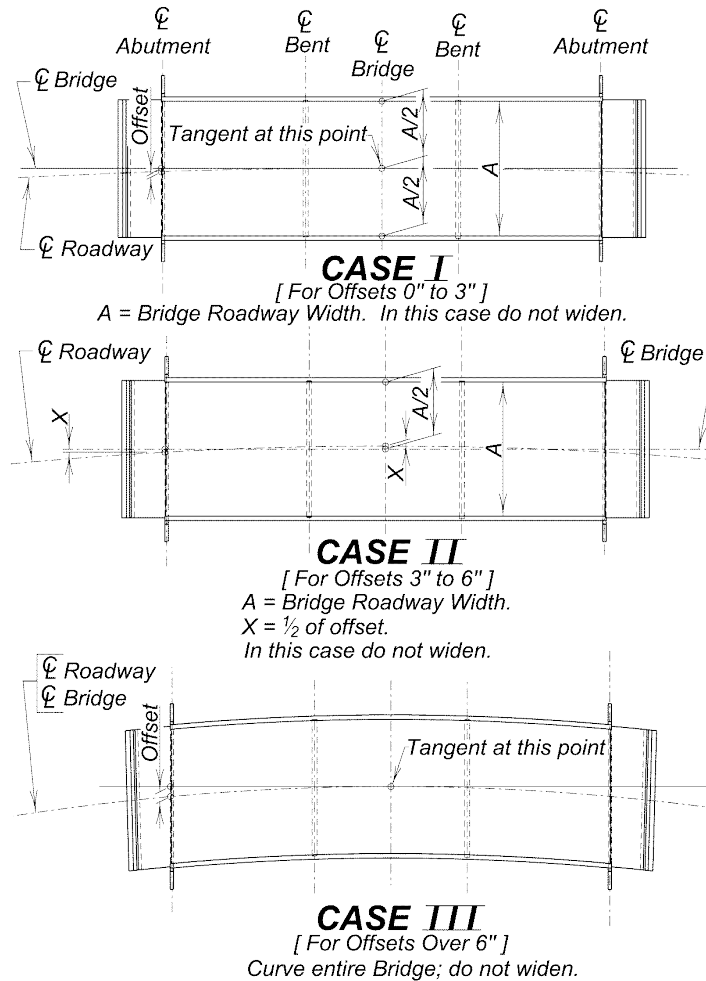

Figure 4.1.1 - 1 Bridge Alignment for Horizontal Curve

When sidewalks or shared use paths are provided in the typical section, practice is to provide for the sidewalks over the structure. Normally, a clear width of 5'- 0" is used for sidewalks and a clear width of 8'- 0" or 10'- 0" is used for shared use paths, however, actual width used is determined by the ORD. Sidewalks may also be provided on structures when it is anticipated that sidewalks will be added leading to and from the structure at a later date.

At grade separation structures, a small curb is provided on the sidewalk/bike path over the roadway below to prevent surface drainage from falling on the driving lanes and shoulders. The curb is ended on each side at a point above the roadway ditch section below.

4.1.1.1.3 Clear Zone

Clear zone and lateral offset for roadside obstacles and slopes are set by the ORD.

4.1.1.2 Bridge Geometrics

In addition to the geometric parameters controlled by roadway criteria, several geometric parameters are dependent upon the structure type, size and location.

When laying out and selecting the following criteria it is the Engineer's responsibility to select and proportion an appropriate structure type and fit the structure to the constraints of the site. It is generally not allowed to change the practices outlined in this manual to force a structure type or span arrangement without expressed prior permission of the Bridge Design Engineer.

4.1.1.2.1 Span Length

When determining span lengths and span arrangements for a structure location, several factors are to be considered and accounted for. The Engineer will consider all hydraulic, environmental, geometric, and construction constraints and provide the most feasible and economic structure/span arrangement possible.

The following office practices have been developed using the department's experience, economics, and structure response as the primary factors to limit spans.

Please note these are guidelines and some site conditions or project parameters may dictate exceeding these limits. However, the designer will get permission from the Bridge Design Engineer prior to specifying any spans over the following limits.

The maximum box culvert cell size normally used is a 12 feet span by 12 feet rise. Single span concrete slab bridge lengths are normally limited to a length of approximately 40 ft. to keep slab thickness reasonable. Single span concrete rigid frame bridges are generally limited to a length of approximately 50 ft. to keep slab thickness reasonable.

Multi-span continuous concrete slab bridges and multi-span concrete rigid frame bridges are generally limited to a maximum span length of 50 ft. and an overall length of approximately 700 ft.

Prestressed girder bridge span lengths are dependent upon many factors including beam section, beam spacing and continuity. Maximum span length for prestressed girder bridges is limited to approximately 140 ft. with 81" deep Minnesota shape girders. Other girder shapes may be considered if the typical fabricators in South Dakota have access to forms for the shapes, with permission from the Bridge Design Engineer.

When the span length required is greater than 140 ft. or superstructure depth is limited by clearance or freeboard constraints, steel girder bridges are typically used.

Span lengths for bridges are generally rounded to the nearest 3 in.

4.1.1.2.2 Abutment Type

The abutment type chosen (integral, sill type, vertical etc.) is chosen based on structure length and type along with other site specific conditions. Standard Office Practice is to use integral (stub) abutments whenever possible. When competent rock is too close to the surface to use piling, vertical abutments on spread or strip footings made integral with the superstructure are used. When structure lengths and/or skews exceed office standards, expansion sill type abutments are used. The following guidelines are used to determine the suitability of integral abutments:

For concrete structures, maximum structure length for integral abutments is approximately 700 ft.

For steel girder structures, maximum structure length for integral abutments is approximately 350 ft.

For all superstructure types, concrete or steel, the maximum skew for integral abutments is 35 degrees regardless of structure length.

4.1.1.2.3 Bent/Pier Type

Several bent and pier types are used by the Department. Office nomenclature refers to a substructure unit as a bent when frame action resists loads and as a pier otherwise. Bent/pier foundations are determined after receipt of the *Report of Foundation Investigation* provided by the Geotechnical Engineering Activity(GEA). Final bent or pier choice is based on several factors including function, economics and aesthetics.

Examples of bent and pier types generally used are shown in Figure 4.1.1-2 through Figure 4.1.1-9.

Pier walls or column bents with web walls are generally only used where debris and/or ice are potential problems or where structure width is such that frame action with columns cannot reasonably be accommodated.

Substructure units are generally built monolithic with the superstructure for continuous concrete bridges and rigid frame bridges. Girder bridges will have fixed bearings unless expansion and contraction movements cannot reasonably be handled by fixed supports, in which case expansion type bearings are used.

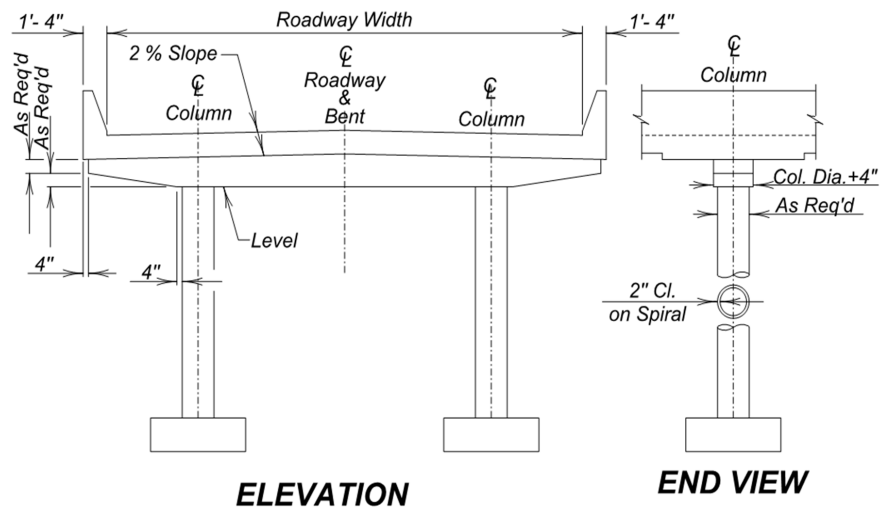

Figure 4.1.1 - 3 Two Column Bent Continuous Concrete Bridge

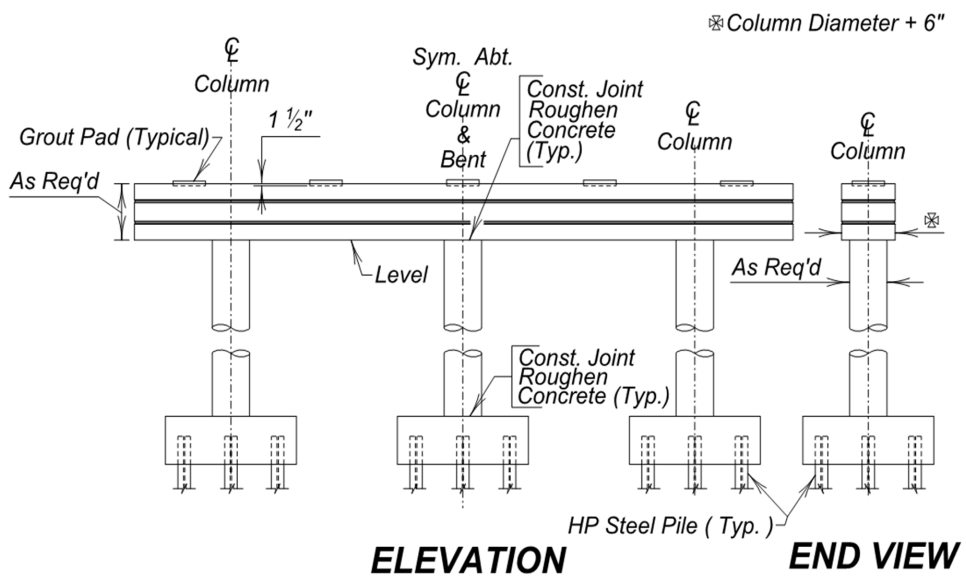

Figure 4.1.1 - 4 Three Column Bent Girder Bridge

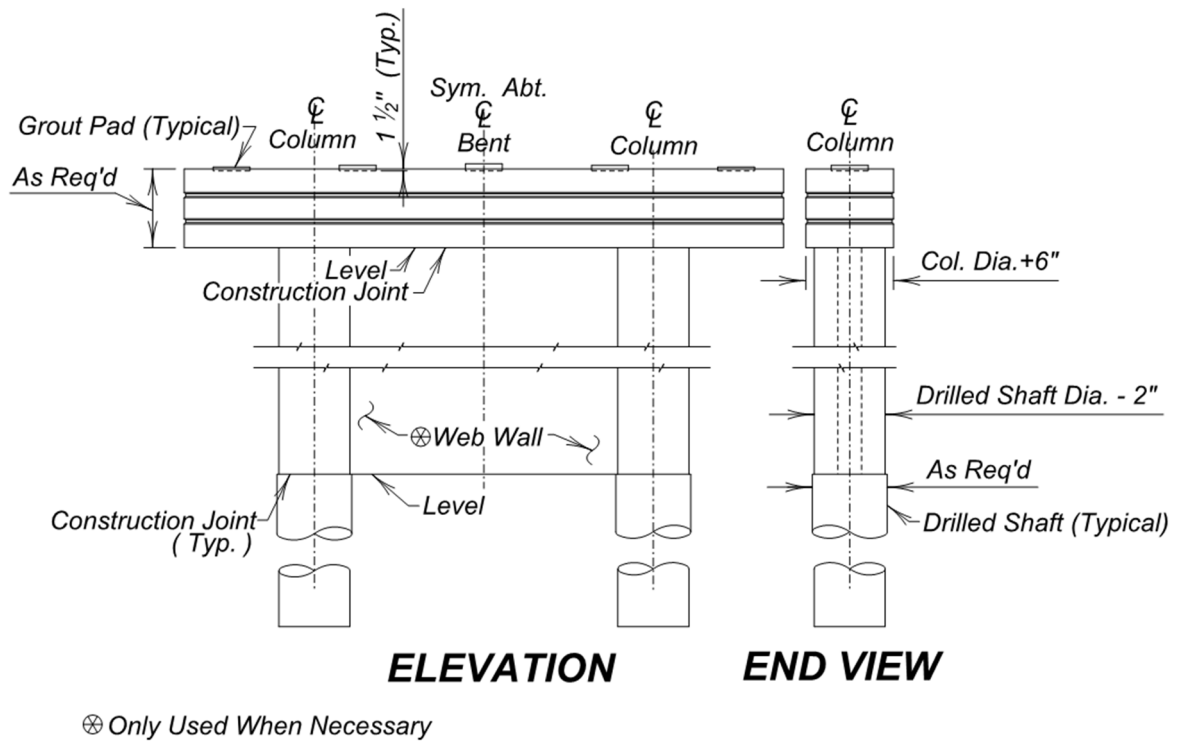

Figure 4.1.1 - 5 Two Column Bent Girder Bridge

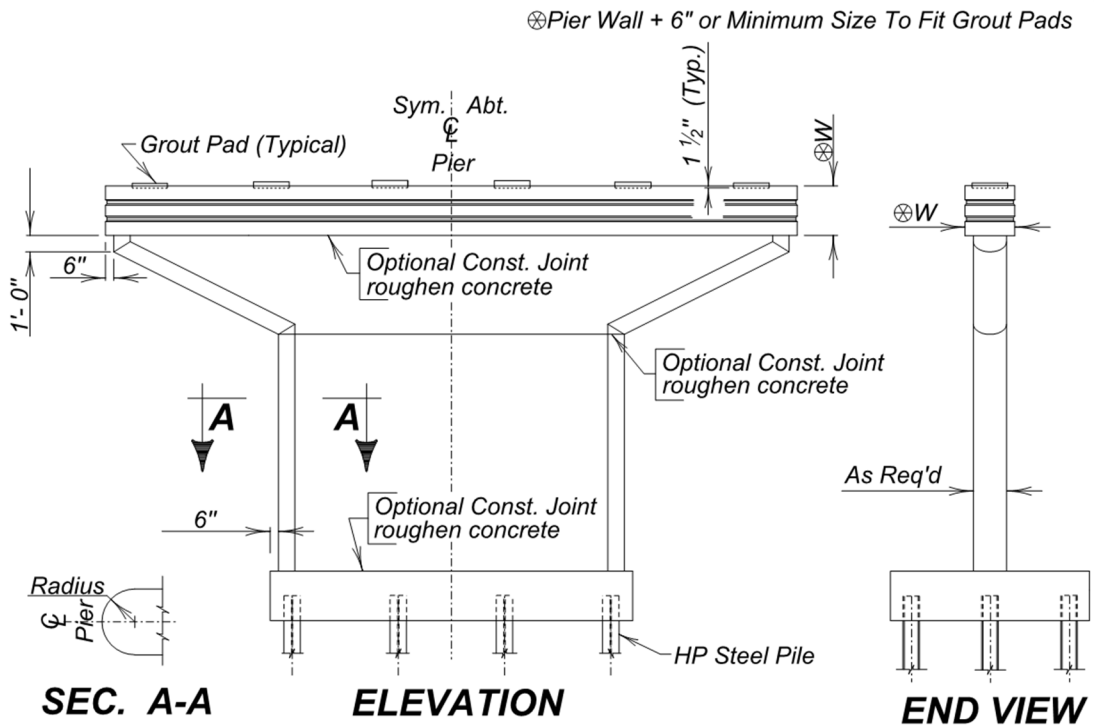

Figure 4.1.1 - 6 Hammerhead Pier Wall Girder Bridge

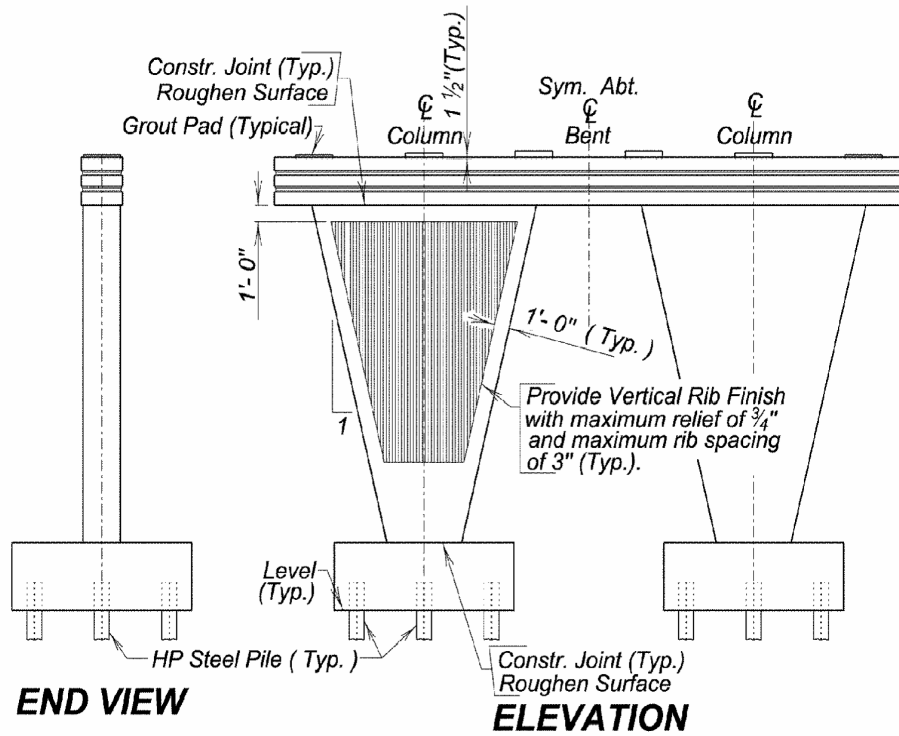

Figure 4.1.1 - 7 Alternate Two Column Bent Girder Bridge

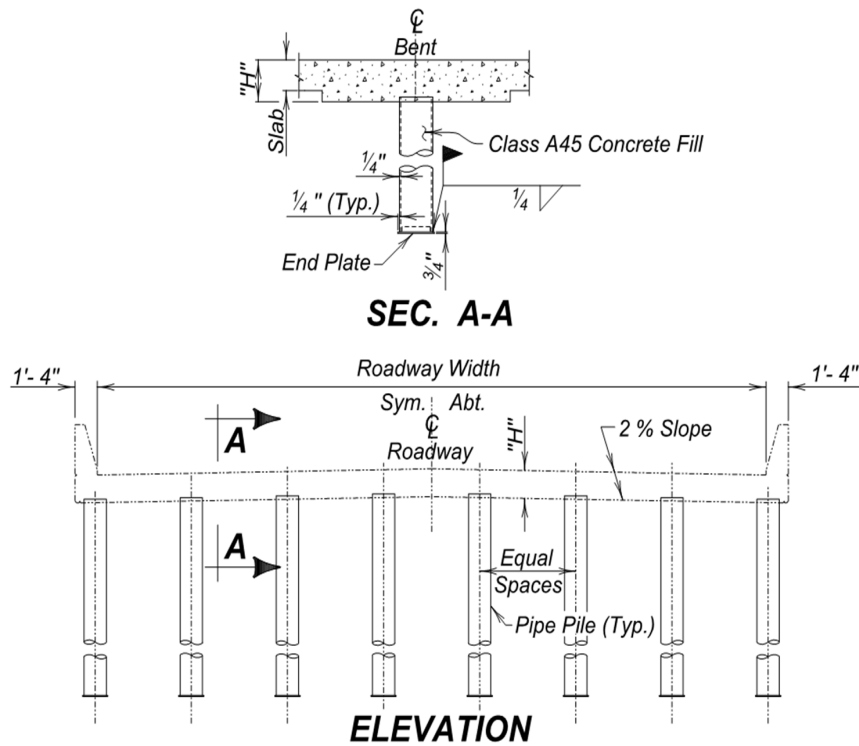

Figure 4.1.1 - 8 Steel Pipe Bent Continuous Concrete Bridge

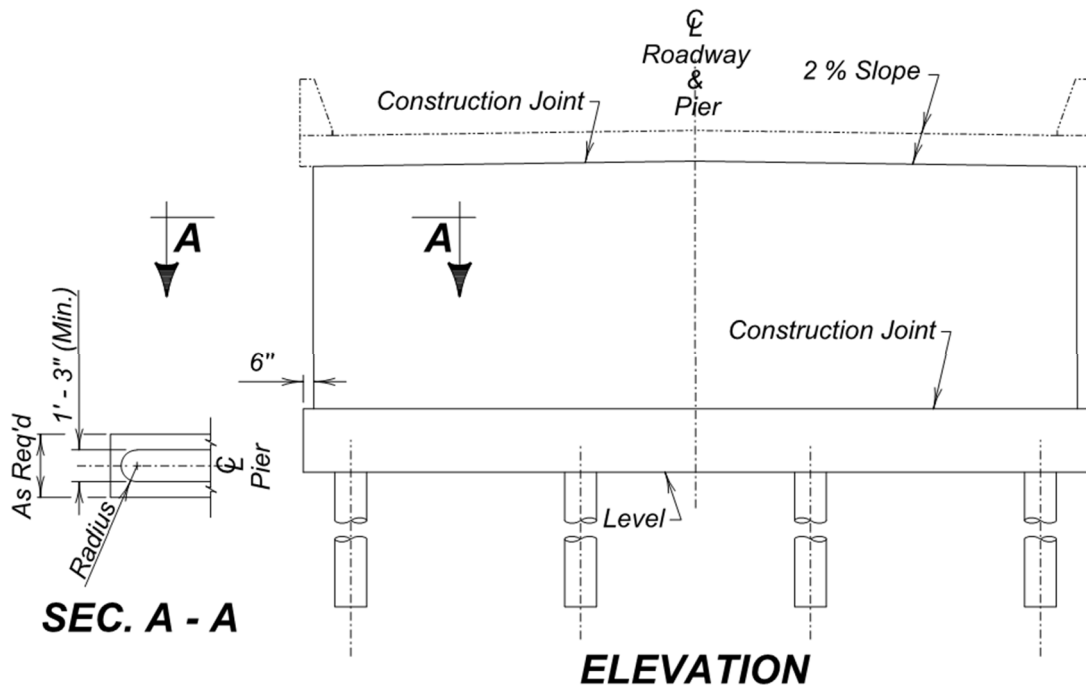

Figure 4.1.1 - 9 Pier Wall on Drilled Shafts Continuous Concrete Bridge

4.1.1.2.4 Approach/Sleeper Slabs

Current practice is to provide approach slabs off the ends of all new bridges on the state highway trunk system, unless otherwise recommended by the GEA. When the GEA recommends that approach slabs not be constructed with the initial bridge construction, provisions are made to incorporate approach slabs at a later date. Bridges on approach or gravel roads generally are not provided with approach slabs.

In accordance with Article 3.11.6.5 of the *AASHTO LRFD Bridge Design Specifications*, when approach slabs are used, no Live Load Surcharge need be applied to the abutment. When approach slabs are not installed with the initial bridge construction, the abutments shall be designed for a Live Load Surcharge in accordance with Article 11.6.1.2 of the *AASHTO LRFD Bridge Design Specifications*.

The standard approach slab for structures in a rural section is full width of the bridge deck between the face of bridge barriers or curbs with an 11 1/4 in. wide by 4 in. high mountable curb on each side of the slab. When the structure is in an urban section, the curbs are built to match the curb section used elsewhere along the roadway. The length of the approach slab for 0° skewed structures is set at 20 ft. along centerline roadway, measured from the Begin Bridge or End Bridge location of the abutment. For skewed bridges, the end of the approach slab is perpendicular to the center line of the road. The center line length should be detailed to the nearest three inches with short side of the approach slab a minimum of

15 feet. This may result in a centerline length longer than 20 ft. The thickness of the approach slab is 9 inches.

Sleeper slabs are normally used at the ends of all approach slabs. The configuration of the sleeper slab is dependent upon the approach pavement type and the need to accommodate expansion from the superstructure. When bridge expansion is accommodated at the joint between the approach slab and the sleeper slab (generally for integral type abutments) a membrane sealant expansion joint is used. When bridge expansion is accommodated at the abutment, the approach slab is tied to the sleeper slab and no joint is used between the sleeper slab and the approach slab. A growth joint (generally another membrane sealant expansion joint) is provided off the ends of sleeper slabs when the approach pavement is concrete. For short bridges (<50 ft.) with asphalt approach pavement, no growth joint is used. The various standard sleeper slab configurations are shown in Figures 4.1.1-10 thru 4.1.1-13.

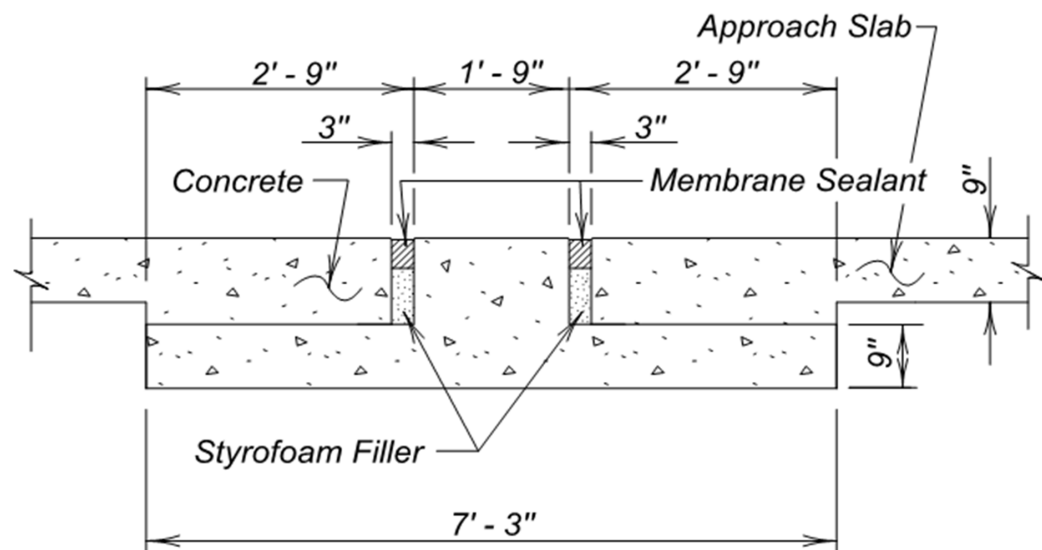

**Figure 4.1.1 - 10 Hat Type Sleeper Slab
(For Use with Concrete Approach Pavement and Integral Abutment)**

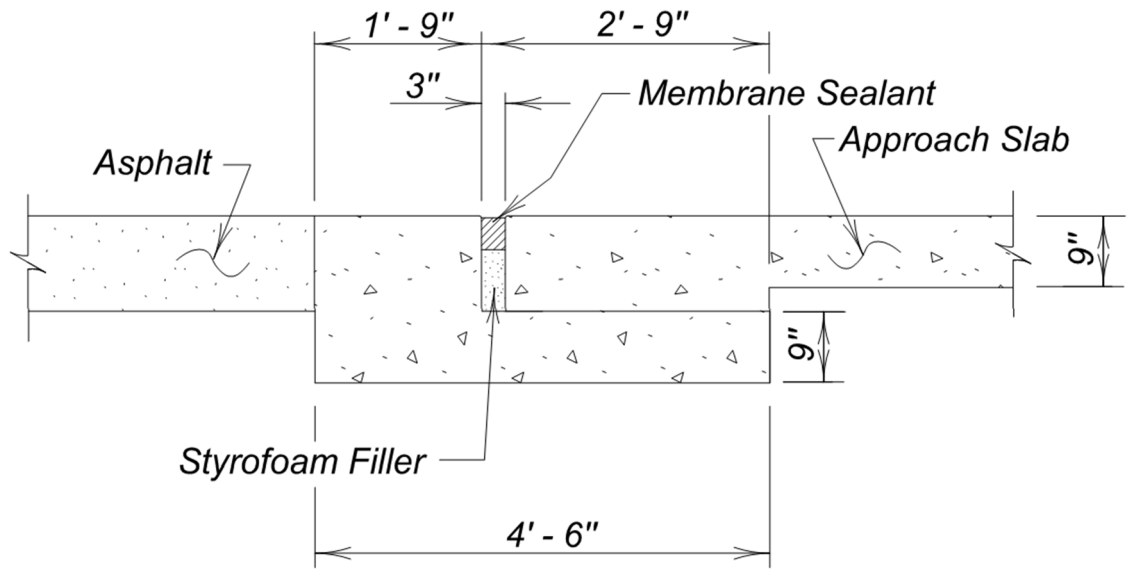

**Figure 4.1.1 - 11 L Type Sleeper Slab
(For Use with Asphalt Approach Pavement and Integral Abutment)**

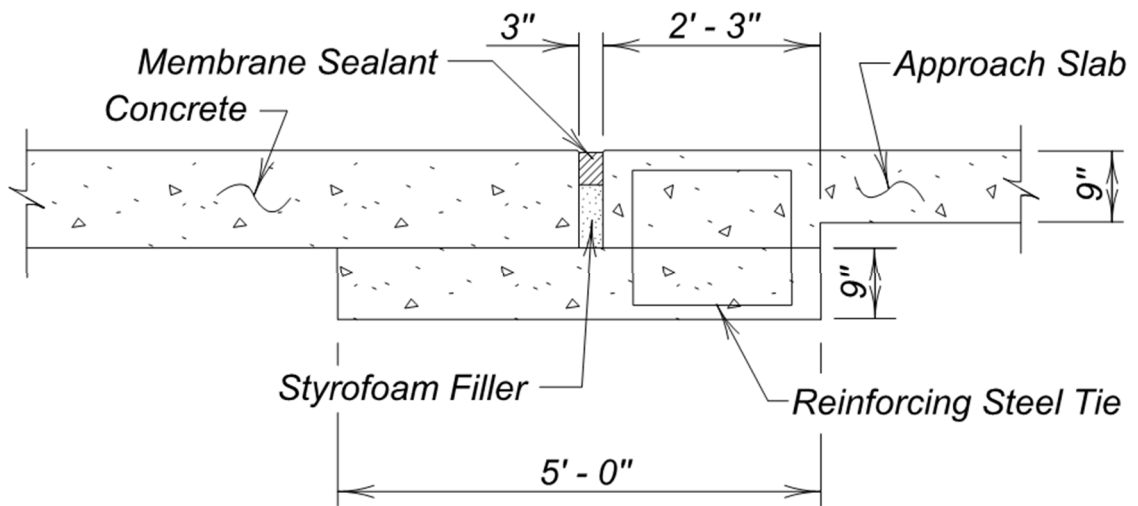

**Figure 4.1.1 - 12 Flat Type Sleeper Slab
(For Use with Concrete Approach Pavement and Sill Type Abutment)**

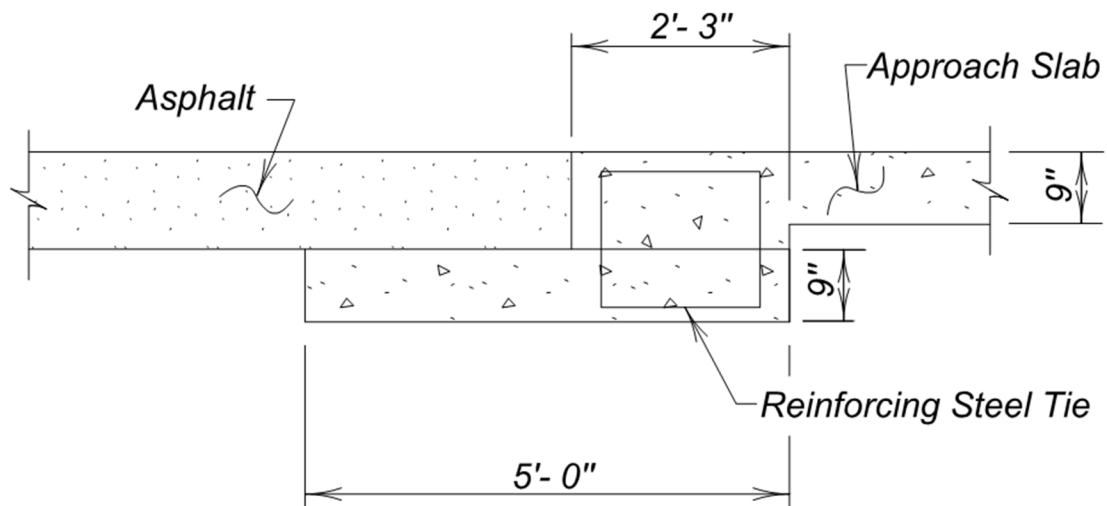

**Figure 4.1.1 - 13 Flat Type Sleeper Slab
(For Use with Asphalt Approach Pavement and Sill Type Abutment)**

4.1.2 Layout Criteria

4.1.2.1 Drainage Structure Sites

The layout of structures at drainage structure sites is based in part upon the data contained in the *Hydraulic Data Sheet* provided by the Hydraulics Section. This data, along with other information regarding roadway geometrics, standard OBD practices, and miscellaneous site specific requirements, is used to prepare structure layouts for distribution to other offices and for use in preparing final construction plans.

4.1.2.1.1 Box Culvert Sites

In referring to a box culvert, the span of the opening is referenced first, followed by the height of the opening. The span and height reference of a multi-cell box culvert is preceded by a number indicating the number of cells as shown in Figure 4.1.2-1.

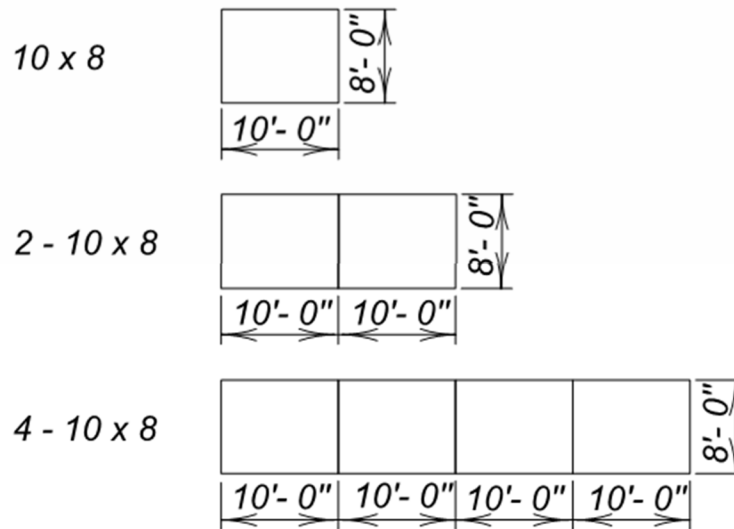

Figure 4.1.2 - 1 Box Culvert Cell Layout

For cast-in-place box culverts, the total length of the barrel is the distance on the longitudinal centerline of the box culvert from parapet to parapet but does not include the parapets. For precast box culverts, the length of the barrel is defined as the length of the box culvert between end sections. The cast-in-place inlet or outlet consists of the parapet and all portions of the wingwalls, aprons, cutoff walls, and barrel beyond the inside face of the parapet. See Figures 4.1.2-2 and 4.1.2-3 for examples.

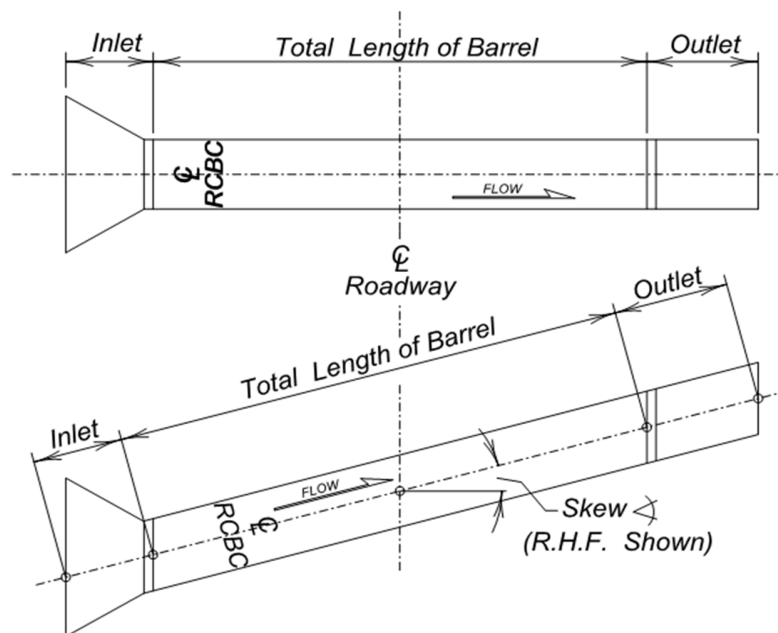

Figure 4.1.2 - 2 Cast in Place Box Culvert Length Layout

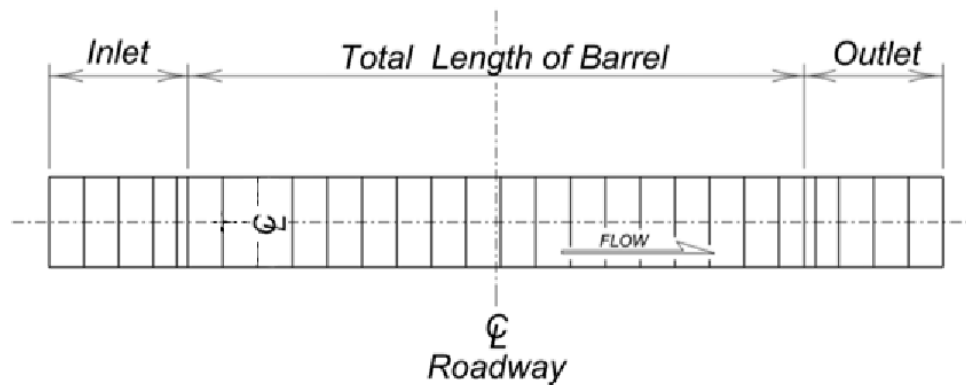

Figure 4.1.2 - 3 Precast Box Culvert Length Layout

Standard cutoff walls for all box culverts are 2 ft. below the bottom of the bottom slab (min.) or 6 inches below any adjacent riprap, whichever is greater. Deeper cutoff walls may be used if required by hydraulic analysis and the depth shown on the *Hydraulic Data Sheet* will be referenced from the bottom of the bottom slab. For cast-in-place box culverts, the deeper cutoff wall recommended by Hydraulics will be used on the apron and cutoff wall across the end of the heel only unless otherwise specified.

Normal practice for state highways is to provide plans for a cast-in-place box culvert installation and include an option for a precast concrete culvert installation unless the following conditions apply:

- Skew of proposed box culvert installation exceeds 10 degrees (for standard zero degree skew precast end sections).
- Culvert end treatments that do not have OBD approved precast details and are determined necessary (flared wing walls, slope tapered aprons, side tapered inlets, skewed end sections, water control structures, etc.).

Exceptions to these general rules may be considered where individual culvert site conditions allow. For instance, a culvert placed diagonally underneath a roadway intersection may fit better with zero skew (square) end sections and therefore a precast option could be viable there even though skew exceeds 10 degrees. Other site conditions such as depth of fill, size of culvert, channel configuration/depth, etc. may also be considered when evaluating viability of precast options. The decision whether to utilize options or not for locations with special conditions will be made during the structure TS&L inspection (with input from participants) and reflected in the site inspection report letter.

Individual culvert options should be entirely composed of one type of construction. No individual options composed of both precast and cast-in-place portions (“partial precast”) will normally be provided.

When specifically requested by the Region/Area office, plans may call for individual sites to be strictly precast type culvert installations (with no other option) due to time/cost constraints associated with the proposed project construction sequencing plan.

All drainage type structure options for a given site must provide similar hydraulic performance. No option shall be allowed that produces a theoretical water surface profile elevation upstream of the inlet more than 0.25 feet higher than the corresponding flared wing box culvert option at the 100-year frequency. In no case shall an option result in a theoretical upstream water surface profile elevation exceeding that of the existing conditions by more than 1 foot at the 100-year frequency (where practical).

Precast box culvert options for proposed multiple barrel cast-in-place concrete box culverts must be composed of the same number of barrels or fewer to be considered equivalent (i.e.: Twin box culverts cannot be an option for a single cast-in-place box. However, an equivalent single precast box may be an option for a cast-in-place twin box). Multiple barrel precast box options must be composed of the least number of barrel section types (i.e.: Triples must be composed of a double and a single side by side rather than three singles side by side; Quads must be composed of two doubles side by side, etc.)

Box culvert extension plans will not include structure options. Extensions shall be accomplished in-kind unless special circumstances apply (i.e.: construction sequencing time/cost considerations, location, etc.).

4.1.2.1.1.1 Cast-in-Place Box Culverts

In calculating the total length of barrel required, the inslope will intersect the parapet between 6" to 9" above the top slab of the box culvert as shown in Figure 4.1.2-4.

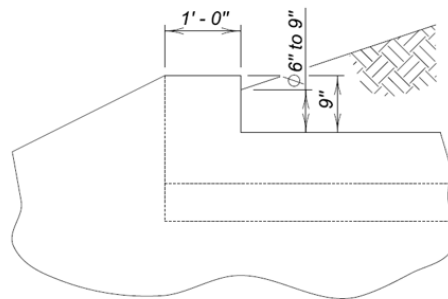

φ Range to be used when proportioning the length of barrel

Figure 4.1.2 - 4 Inslope Parapet Intersection (Cast in Place)

The total barrel length required shall be divided into sections not to exceed 60 ft. Barrel
April 2026

lengths are rounded up to the nearest foot. Minimum section length is 20 ft. Generally, section lengths are determined by fill height requirements with design fill heights in 1 ft. increments i.e. 2-5 ft., 2-15 ft. etc. A minimum of 2 ft. of fill is preferred due to LRFD live load considerations, however, a minimum fill height over the box culvert of 1 ft. over the entire finished roadway is allowed if necessary. Minimum fill heights are measured at the finished shoulder. In rare instances, it may be necessary for the top of the top slab of a box culvert to be the driving surface, with approval of the Bridge Design Engineer. Fill height designations for plans shall be an F followed by the maximum fill height over each section.

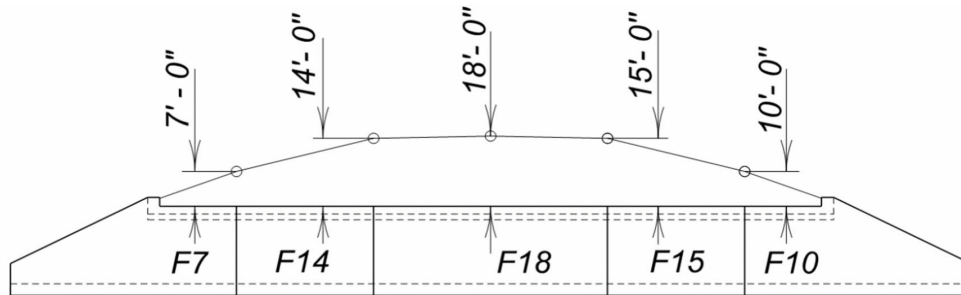

Figure 4.1.2 - 5 Box Culvert Fill Height Designation

For cast in place box culverts, parapets are normally placed parallel to the centerline of the roadway, or on horizontally curved alignments, parallel to the tangent at the centerline station. When the skew of the box culvert is 5 degrees or less, the parapets are constructed normal to the centerline of the culvert. An extraordinary combination of skew, grade and fill may necessitate the use of non-parallel parapet placement.

The skew angle of box culverts is the angular deviation between a line normal to the roadway at the centerline station of the box culvert, and the centerline of the box culvert, and is referred to as either RHF (right hand forward) or LHF (left hand forward).

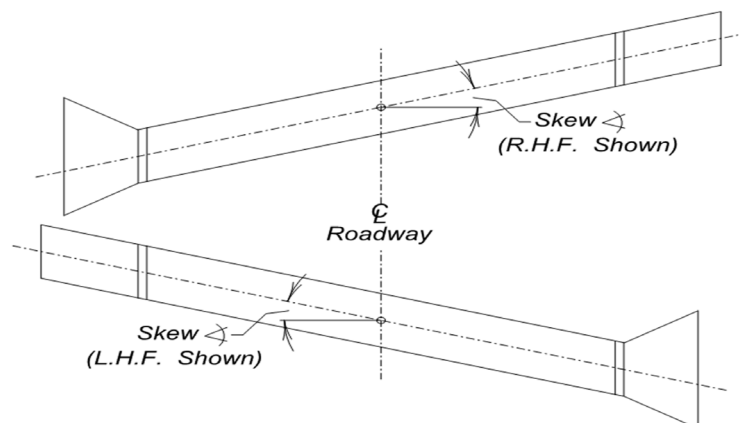

Figure 4.1.2 - 6 RHF and LHF Box Culvert Skew

Inlet and outlet lengths are determined by skew and embankment inslope to the end of the
April 2026

wing. Standard practice is to use a wing height of 1'-9" above the channel flowline at the end of the wing (when flowline is depressed for aquatic organism passage the wing height shall be 2' - 9" from the flowline of the box). When the box culvert flowline is submerged for environmental purposes, the height of the wing at the end is increased as necessary to maintain the 1' - 9" dimension above flowline. A dirt pile-up of one-half to full height of this dimension is permissible; however, inlets should be investigated to ensure that the dirt spill around the end of the wing does not encroach into the area of the main flow of water (inside face of exterior wall). When straight inlet wings are used, the Hydraulics Section should be contacted to ensure that any dirt spill present will not adversely affect hydraulics.

Flare, or flare angles are the angular deviation in alignment of the wingwall and the barrel wall from which the wingwall extends.

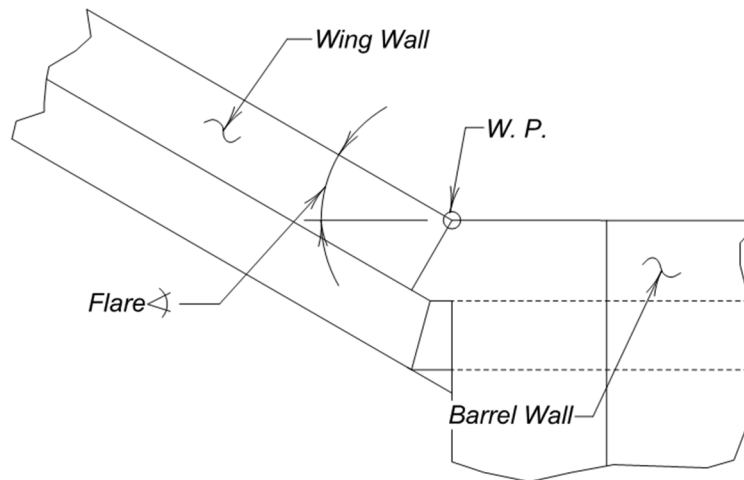

Figure 4.1.2 - 7 Cast in Place Box Culvert Wing Flare Diagram

Working points are located at the point where the outside of the exterior wall changes to the wing wall beyond the parapet. This point will occur at outside of the wall where the wall makes a bend for flared wingwalls. This point should not result in the inside face wall bend point occurring at a point 'below' the parapet but rather at or beyond the front face of the parapet. The location of the W.P. depends on the skew angle of the box culvert and the flare angle of the wingwall. Working points are also located at the end of the wingwalls at non-monolithic aprons.

FLARED WINGS ON A SKEWED BOX CULVERT

When the Exterior wall "bends" and becomes a flared wing, the "bend" shall occur at the edge of the parapet or beyond, but NEVER under it. Also, the "bend" of the wall shall never diminish the 1'-0" normal width of the Parapet. A constant wall, or wing thickness, shall be maintained.

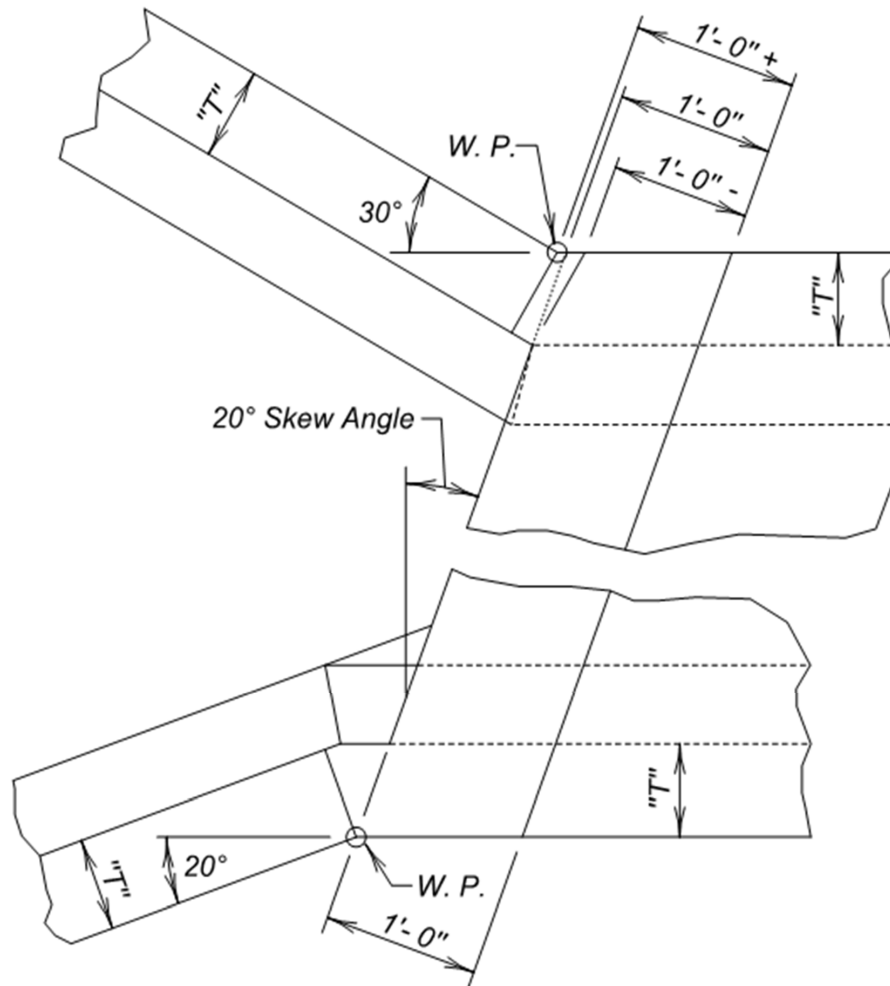

Figure 4.1.2 - 8 Cast in Place Box Culvert Working Points

4.1.2.1.1.2 Precast Box Culverts

In calculating the total length of barrel required, the dirt slope is 'zeroed out' at the top of the top slab 6" away from the inlet/outlet opening as shown in Figure 4.1.2-9.

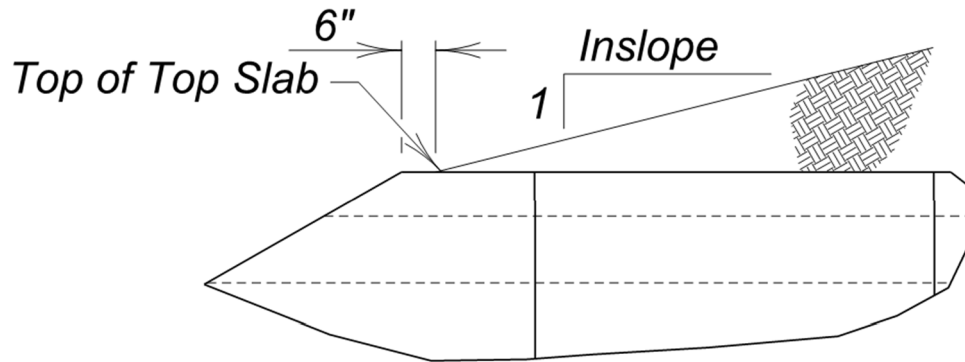

Figure 4.1.2 - 9 Precast Box Culvert Inlet/Inslope Intersection

The total barrel length required, as calculated above, should be rounded up to a whole number of 6 ft. precast box culvert section lengths. Barrel runs will be use as many 6 ft. or longer sections as possible with only two shorter sections per barrel run allowed. The shorter sections should be placed in the interior portion of the precast box culvert barrel length, but not immediately adjacent to one another. Note minimum length of the shorter box culvert sections will not be less than 4 ft.

Precast inlet and outlet lengths used are those available from industry precast manufacturers. Where the inlet or outlet section includes a length of top slab, the barrel length may be reduced, and part of the inlet or outlet used as barrel section to accommodate fill.

4.1.2.1.1.3 Box Culvert Extensions

When an existing box culvert does not fit the proposed grading section or is inadequate for clear zone requirements, consideration is given to extending the culvert. The decision whether to extend the existing culvert or replace with a new culvert is based on several variables including age of the box culvert, structural condition, and hydraulic capacity of the extended box culvert and channel. Consideration is also given to the anticipated length of time that an extended culvert may be in service before another opportunity for construction arises and whether or not the culvert is structure length and will receive regular structure inspections.

When the decision has been made to extend a box culvert, the required overall length of barrel and the wing lengths are determined as described previously. The actual length of the extension on one or both sides of the roadway is then determined based on the total barrel length required and the length and location of the existing culvert. When necessary, survey is requested to locate the ends of the existing structure with respect to the centerline of the roadway. When a culvert is to be extended on both sides of the roadway, it is desirable to make the extensions the same length on each end of the culvert, however, if the length of extension required varies significantly from one side of the roadway to the other, different length extensions are used. Minimum extension length is 5'-0".

When extending a cast-in-place box culvert, any portions of the existing box culvert inside the face of the parapet that are in poor condition (exhibiting deterioration or disintegration of concrete, extensive cracking, considerable efflorescence, leaching, concrete spalling, or opened construction joints) are removed and replaced when the extensions are added. It is common for the parapet region of the existing box culvert to exhibit deterioration due to roadway deicing salt runoff. When damage is visible, or it appears that deterioration in the near future is a possibility, the existing parapet and a portion of the top slab are removed and replaced.

4.1.2.1.2 Bridge Sites

Bridge length for trapezoidal channels is determined using the berm toe stations, elevations and slopes provided on the *Hydraulic Data Sheet*. The berm slope shown on the *Hydraulic Data Sheet* is taken normal to the channel. The configuration of the berm top near ends of the bridges varies with bridge type as follows:

For continuous concrete slab bridges with integral abutments, the elevation of the top of the berm is set at 4.5 ft. below the top of deck slab at low curb at the elevation along the centerline of the abutment. The standard width of the berm top is set at 7 ft. from the back face of the abutment, normal to the back face.

For prestressed and steel girder bridges with integral abutments, the elevation of the top of the berm is set at 2 ft. below the low bottom of girder elevation along the centerline of the abutment. The standard width of the berm top is set at 7 ft. from the back face of the abutment, normal to the back face.

For steel or prestressed girder bridges with sill type abutments, the elevation of the top of the berm is set at 1 ft. below the top of the abutment sill. The standard berm top width is set as the width of the abutment sill plus 5 ft. normal to the back face of the backwall.

When vertical abutment bridges are specified on the *Hydraulics Data Sheet*, the length shown is the clear distance between inside faces of the abutment wall normal to the channel centerline.

Bent or Pier locations should be chosen with regard to foundation conditions and superstructure type to provide an economical structure. Where possible, the bents or piers should be kept out of the main flow channel and positioned to minimize interference with existing substructure units. Bents or Piers located over waterways should be aligned as closely as possible to the direction of flow at flood stage. Single column pier substructures should be used where channel migration near the bridge is likely.

These guidelines are intended for normal bridge layouts. Special site or structure conditions may warrant the use of differing bridge berm or bent/pier configurations.

4.1.2.1.3 Reinforced Concrete Pipe Sites

When reinforced concrete pipe (round or arch) is specified on the *Hydraulic Data Sheet* and plans are prepared by OBD, the total length of pipe required is calculated by ‘zeroing out’ the inslope at the top of the pipe. The total pipe length required should be rounded up to a whole number of standard pipe section lengths. Where pipe is available in several laying lengths, the longest lengths should be used with no more than two shorter lengths allowed in any one line of pipe. The short lengths should be located in the interior portion of the pipe length, but not immediately adjacent to one another. Standard flared or sloped end sections are used at the ends of the pipe. Where the end sections include a length of pipe, the length of pipe specified may be reduced by the length of pipe included in the end sections.

When multiple lines of pipe are specified, office practice is to maintain 12 ft. clear distance between the lines of pipe to allow for compaction equipment. Where site conditions dictate closer spacing of pipe, a flowable fill material is used between the lines of pipe.

Normal practice is to use standard cast-in-place headwalls with a 3 ft. cutoff wall (measured from flowline down) at the ends of the sloped or flared end sections. When a deeper cutoff wall is specified on the *Hydraulic Data Sheet* it is measured from flowline down.

At skewed pipe sites, pipe length may be controlled by the fit of the standard headwall and typical section. Office practice is to maintain the typical section to the top of the standard headwall and warp the inslope to fit as required.

4.1.2.1.4 Miscellaneous Drainage Sites

Miscellaneous hydraulic sites for drainage features not covered here are laid out according to the criteria listed on the *Hydraulic Data Sheet* in conjunction with other data as required.

4.1.2.2 Grade Separation Structures

The layout of structures at grade separation sites is based in part upon the roadway geometrics provided by the ORD. This data, along with requirements set forth in the *AASHTO LRFD Bridge Design Specifications*, the *SDDOT Road Design Manual*, FHWA requirements and practices outlined in this manual are used to prepare structure layouts for distribution to other offices and for use in preparing final construction plans.

Berm configurations for the various bridge types are normally the same as listed in Section 4.1.2.1.2. Berm slopes are 2:1 unless otherwise recommended by GEA.

Horizontal and vertical clearances used for various configurations are shown in Figure 4.1.2-10 through Figure 4.1.2-14. The specified clearances are to be maintained over the entire surfaced width (design lanes plus shoulders) for vertical clearance and through the entire limits of the bridge for horizontal clearance. Horizontal clearances shown are normal to centerline of roadway.

★ Shield bent as required by AASHTO Roadside Design Guide.

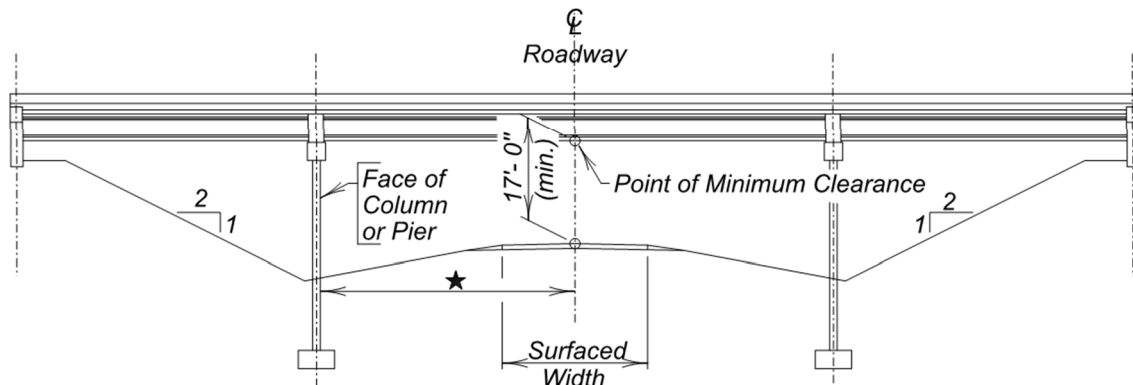

Figure 4.1.2 - 10 Structure Over State Highway

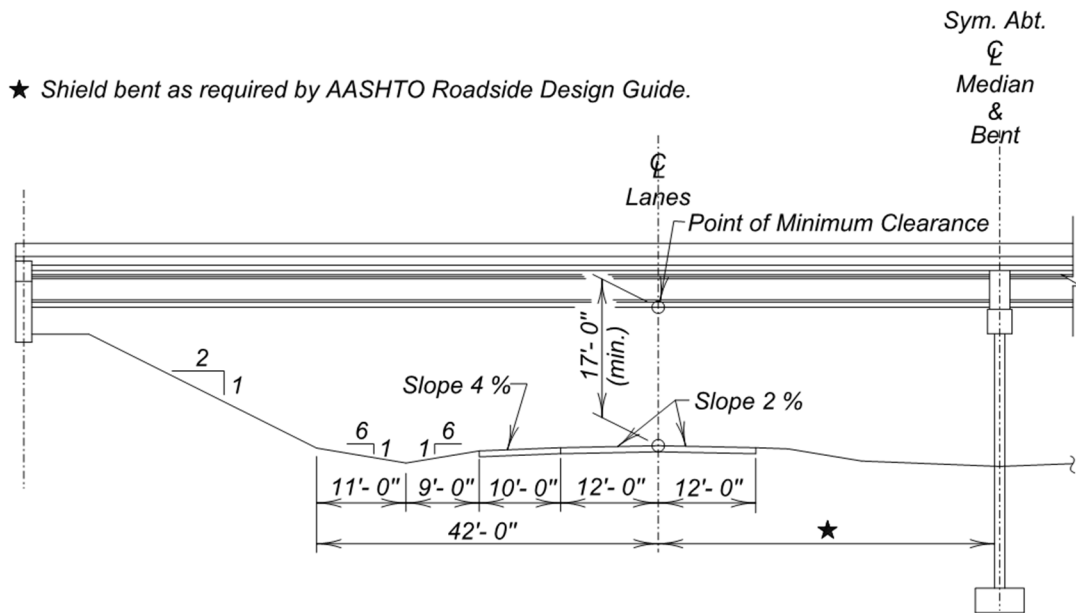
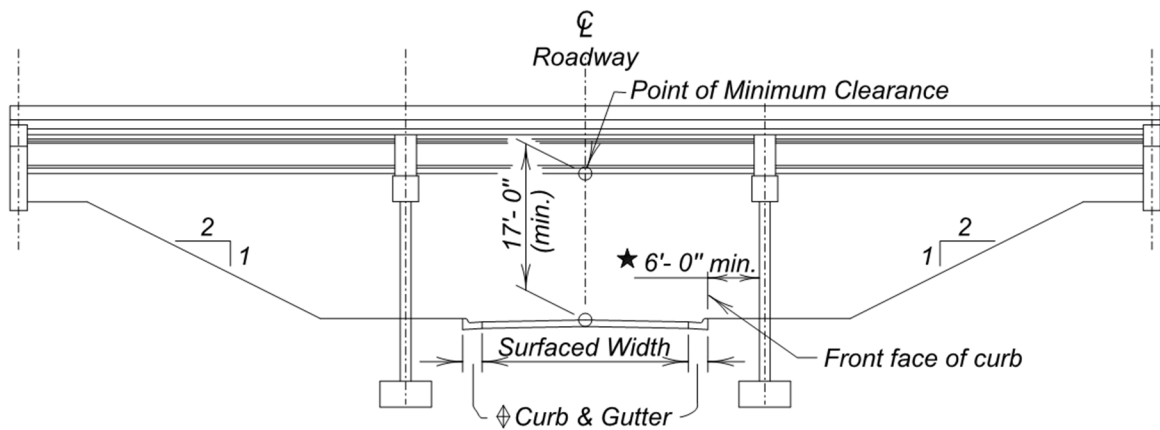

Figure 4.1.2 - 11 Structure Over Rural Interstate Highway

★ Shield bent as required by AASHTO Roadside Design Guide.
6'-0" minimum clear is Road Design minimum.



◆ Type B curb and gutter, design speed for urban street speed limit 40 mph and under

Figure 4.1.2 - 12 Structure Over Urban Street

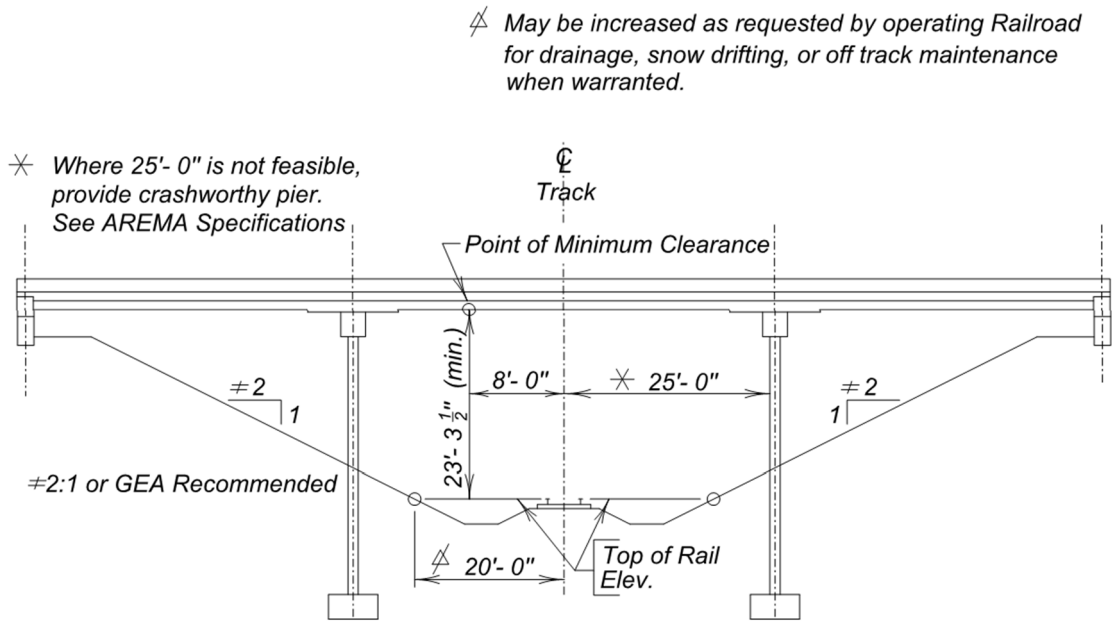

Figure 4.1.2 - 13 Structure Over Railroad

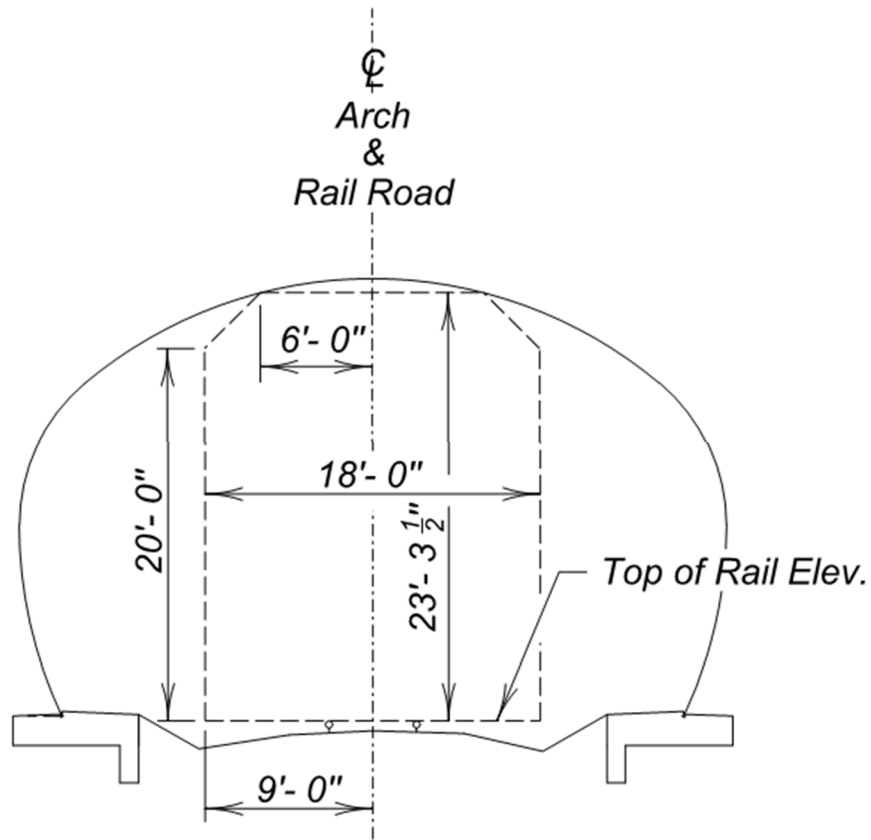

Figure 4.1.2 - 14 High Profile Plate Arch Over Railroad

4.2 FINAL DESIGN

4.2.1 General

Final design is the process of determining the final components of a given structure, their relationship to each other and their structural composition to provide a safe, economical and efficient structure. The final structure design should be performed in accordance with applicable codes, specifications, and this manual resulting in calculations and design details that can be used by structural draftsmen to produce structure plans for letting and construction.

To provide the traveling public the safest and most economical structures possible the OBD goes to great lengths to select the appropriate bridge site layout and efficient design of structural members. All main structural members will be proportioned to adequately resist the force effects applied to them. However, care will be taken to ensure the demand over capacity ratio at the controlling load case and force effect is as close as practical to 1.0.

4.2.1.1 QC/QA

The QC/QA practice herein described applies to all structure design performed in-house as well as all structure design for the Department performed by outside consultants.

The purpose of the SDDOT Office of Bridge Design QC/QA practice is to ensure that quality structure designs, plans, and specifications are produced. To that end, the QC/QA practice includes several checks and reviews. This process, by its very nature, can become adversarial and care must be taken to focus on the end goal of producing a quality product.

It is the intent of this process to provide complete plan sets with minimal errors at the end of the QC/QA process. Department review is not part of the process described in this document and any inconsistencies between the designer and check designer will be corrected prior to department review. OBD engineers and contracted consultants will have the knowledge and experience to perform the QC/QA process prior to department review and provide a relatively error free set of plans that follow SDDOT standard practices and format.

4.2.1.1.1 Quality Control

The structural design engineer and structural drafter both play a role in quality control. The design engineer is responsible for ensuring that appropriate specifications are used, specification interpretation is in accordance with standard practices, design assumptions are appropriate for the structure or structure component involved and calculations are

accurate. In addition, the design engineer is responsible for checking drafted plans to ensure that the plans correctly depict design intent.

The drafter is responsible for the quality and consistency of the structure plan sheets. The drafter must ensure that the plan sheets follow standard drafting practices and contain adequate information to allow for structure construction. Plans must be clear and concise, and details should be scaled such that they are easily read. When individual projects contain multiple structure plan sets, the plans must be consistent between structure sets.

Both the design engineer and the drafter must check their own work. Design calculations must be checked by the designer to eliminate errors and ensure that correct structural engineering theory and practice was applied. Drafters must check completed plans before engineer review to ensure that the plans are complete, without error and follow conventional drafting practices.

4.2.1.1.2 Quality Assurance

Quality assurance consists of an independent check design, an internal OBD review of the structure plans, and a SDDOT department wide review of the structure plans as part of the complete project plans.

The independent check design is performed by a second design engineer and intended to ensure that the design calculations, plans and specifications are correct and error free. It is vital that the independent check design is not simply a check of the initial designer's calculations, but independent design calculations and computer analysis, if applicable. After completion of the design and check design, it is the responsibility of the two design engineers to resolve any differences in design calculations and details to provide a consistent set of calculations and details for drafting, as well as for future reference. Differences that cannot be resolved by the design engineer and check design engineer shall be taken to the Bridge Maintenance Engineer or the Bridge Design Engineer, as appropriate, for resolution. The check design engineer is also responsible for checking drafted plans to ensure that the plans correctly depict design intent.

4.2.1.1.3 QA/QC Reviews

For SDDOT internal plan preparation the only required reviews are the OBD Review and Department review. It is expected that during the design process the Designer and Check Designer will have adequate knowledge of OBD practices, and oversight during the design process.

Consultants that have successfully demonstrated that they are familiar and proficient with OBD and Department practices, the only required reviews are the OBD Review and

Department review. Additional Reviews may be required at the discretion of the SDDOT Bridge Design Engineer or Bridge Maintenance Engineer.

Consultants with minimal experience working with the Department, on non-typical, or complex projects, will provide 30%, 60%, Office, and Department reviews.

For Locations that cross railroad right of way see Appendix I for reviews required by the railroad.

4.2.1.1.3.1 Concept plan

A Concept Plan is required to be submitted to the railroad and will include Plan, Elevation, and typical section of the proposed structure showing all applicable vertical and horizontal clearances. The submittal for the concept plan will also outline preliminary construction phasing, and a photo log of the proposed location.

4.2.1.1.3.2 30% Review Plans

30 % Review Plans will consist of the General Drawing with tentative index of sheets, Estimate of Structure Quantities and notes sheets with applicable notes and bid items (w/o quantities), and preliminary substructure and superstructure details (Rebar Schedule and bend details not required).

The 30 % Review Plans will be reviewed by the squad leader or consultant manager and the Bridge Design Engineer or Bridge Maintenance Engineer as applicable.

4.2.1.1.3.3 60% Review Plans

60% Review plans will consist of all applicable structure sheets. General substructure and superstructure details will be provided, dimensions of structure elements and elevations will be provided, final reinforcing details and quantities not required, however it is expected that partial reinforcing detail and quantities be provided.

60% Review plans will be reviewed by the Bridge Design Engineer or Bridge Maintenance Engineer as applicable.

4.2.1.1.3.4 90% Review Plans (OBD Review)

90% Review Plans will consist of all structure sheets fully detailed with quantities.

The 90 % Review Plans will be reviewed by the Bridge Design Engineer, Bridge Maintenance Engineer, Bridge Construction Engineer, and the Bridge Hydraulics Engineer.

4.2.1.1.3.5 95% Review Plans (Department Review)

95% Review Plans will consist of the 90% review set with all applicable changes made from the OBD review. 95% plans will be submitted to the project manager and will be incorporated with the other sections of the plan set for department review.

The list of reviewers varies by project type and location. All comments generated by the Department Review pertaining to the structure plans must be addressed by the structure designer and check designer. Review comments not incorporated into the plans must be brought to the attention of the Bridge Maintenance Engineer or Bridge Design Engineer, as appropriate. A record of the review comments and subsequent resolution must be kept with the department review plans. In addition, a letter is required to the Project Coordinator describing comment resolution. For structure plans prepared in-house this letter shall be prepared under the direction of the assigned squad leader and for consultant prepared structure plans this letter shall be prepared by the consultant.

4.2.1.1.4 General

Inherent in the preparation of quality structure plans and specifications is well qualified engineering and drafting personnel. The structure designer and check designer, as well as the drafter, should have a level of experience commensurate with the complexity of the structure being designed. Less experienced personnel should be under the direct supervision of experienced bridge engineers. While it is preferable to have one designer and one check designer for each structure, there may be times when this is not possible and multiple design engineers are required. In these cases, care shall be taken to ensure that all portions of the structure are adequately checked. For consultant designed structures, all rules and regulations as set forth by the South Dakota Board of Technical Professions shall be followed.

Design and check design calculations should include the design criteria, design assumptions, loads, structural analysis and individual member design calculations, and computer program input and output. Calculations may be longhand calculations or computer-generated design calculations; both are acceptable. However, it is the responsibility of the designer and check designer to understand what the computer is modeling and how that affects the design details of the structure. All calculations, whether longhand or computer generated shall be marked with the project number, structure number if applicable, and dated. In addition, the designer and check designer must initial their calculations. For new bridge structures and major rehabilitation of existing bridge structures, calculations are generally broken into superstructure and substructure designs. For all structures, it is important that the above information be arranged in a logical order and be neat and orderly. Project correspondence (for example, hydraulic data sheets, roadway design correspondence,

etc.) should not be copied and made part of the design calculations. A copy of consultant design and check design calculations shall be included with the final deliverables.

Check prints serve as a check of the drafting and also as a check of the design as assembled into construction plans. As such, every item on the check prints must be checked to ensure that the plans are correct and depict the engineers' intent. Standard practice is to have the designer and check designer highlight in yellow everything on the check prints that is correct and mark in red any revisions or corrections needed. The designer and check designer must initial and date check prints upon completion of drafting review. This procedure may be varied by consultants; however, a thorough check of drafted plans must still be made by the designer and check designer.

Construction plans must include the initials of the designer, check designer and drafter and also must identify the firm or SDDOT office that produced the plans. In addition, plans prepared in the OBD shall include the signature of the current Chief Bridge Engineer. Individuals performing the design and check design shall verify that proper initials are shown in the "DESIGNED BY" or "CHECK DESIGN BY" box on each sheet as appropriate and the individual performing the drafting shall verify that the proper initials are shown on each sheet in the "DRAFTED BY" box. The standard portion of the title block is used to identify the designer, check designer, drafter and Chief Bridge Engineer as well as office of plans preparation is shown in Figure 4.2.1-1 Consultant plans may use this block, or others as desired, however, the format used must contain the same information. The firm or SDDOT office that prepared the structure plans need only be identified on the first sheet of the structure plans.

PLANS BY: OFFICE OF BRIDGE DESIGN, SOUTH DAKOTA DEPARTMENT OF TRANSPORTATION	DESIGNED BY	CK. DES. BY	DRAFTED BY	BRIDGE ENGINEER
	XX	XX	XX	

Figure 4.2.1 - 1 General Title Block Requirements

4.2.1.2 Load Rating

See SDDOT Load Rating Manual

4.2.1.3 Design Method

All new highway structures, except supports for highway signs, luminaires and traffic signals are designed in accordance with the latest edition of the *AASHTO LRFD Bridge Design Specifications*. Highway signs, luminaires and traffic signal supports are designed in accordance with the latest edition of the *AASHTO Standard Specifications for Structural Supports for Highway Signs, Luminaires, and Traffic Signals*. Box culvert extensions are

designed to the same design specifications as the original culvert.

4.2.1.4 Load Modifiers

Equation 1.3.2.1-1 in the AASHTO LRFD Bridge Design Specifications is the basis of the LRFD methodology. This equation includes a load modifier η , which in turn has three components: ductility, η_D , redundancy, η_R and operational classification η_I . Most new structures will be designed with a load modifier of 1.0, however, office practice is to use load modifiers as shown in Table 4.2.1-1.

Table 4.2.1-1

Load Modifier	Value	Condition
Ductility (η_D)	1.00	Ductile Structures
Redundancy (η_R)	1.00	Redundant Structures
	1.05	Non-Redundant Structures
Classification (η_I)	1.00	All structures except as noted below
	1.05	Missouri River Structures & Structures with projected ADT > 30,000

4.2.1.5 Distribution of Flexural Reinforcement

For concrete sections in which the flexural tension in the section exceeds 80% of the modulus of rupture, Article 5.6.7 of the AASHTO LRFD Bridge Design Specifications requires the spacing of the tension reinforcement to not exceed the value given by equation 5.6.7-1.

When calculating the allowable reinforcing spacing, the exposure factor, γ_e , shall be taken as Class 1 for all surfaces not exposed to deicing chemicals and Class 2 for all surfaces exposed to deicing chemicals.

When calculating d_c , do not include the ¼ inch wear on the surface assumed for deck slabs or the 1 in. additional cover provided at the bottom of the bottom slabs of box culverts to account for uneven ground level.

4.2.2 Loads

In general, structures are designed for the loads, loading conditions, load factors and resistance factors specified in the applicable AASHTO specifications. Exceptions to the AASHTO codes for specific structures are listed with the structure type in question elsewhere in this manual. Other loading practices are listed in sections 4.2.2.1 through 4.2.2.5

4.2.2.1 Dead Loads

All bridge structures, except those on approach roads, are designed for a future overlay of 22 psf. The future wearing surface is not included in the initial calculation of dead load deflections.

For girder type structures, the barrier and any cantilever sidewalk loads are distributed evenly to the beams within 20 ft. from the curbline or 1/2 of the roadway width, whichever is less. The overlay load is distributed evenly to all girders. These loads are applied to the composite beam sections.

For slab type structures, the barrier and any cantilever sidewalk loads are designed to be taken by the edge beam.

4.2.2.2 Live Load

Bridge structures will be designed for the AASHTO HL-93 live load, unless otherwise approved by the Bridge Design Engineer.

4.2.2.3 Seismic Load

Structures are designed for AASHTO Seismic Performance Category 1.

4.2.2.4 Soil Load

A value of 120 lb./ft.³ is used for normal soil unit weight.

A value of 40 lb./ft.³ equivalent fluid pressure is used for lateral earth pressure, unless otherwise noted in this manual.

4.2.2.5 Thermal Forces

All structures are designed according to Section 3.12 of the AASHTO LRFD Specifications using Procedure A. The temperature range used shall be for the cold climate.

All thermal movements are assumed to take place from the center of the structure for structures with symmetrical substructure stiffness, and proportionally for asymmetrical substructure stiffnesses.

4.2.2.6 Ice and Debris Load

April 2026

Ice load is only applied to structures over major streams and rivers where site characteristics determine that significant ice conditions may occur. Debris concerns will be addressed with the ice load and/or adjusting the drag coefficient for the substructure for the stream pressure equation in the AASHTO LRFD Bridge Design Specifications.

Ice thicknesses are taken from the USGS publication *Evaluation of Factors Affecting Ice Forces at Selected Bridges in South Dakota*, published in 2002. Ice thicknesses are shown in Figure 14 of the above referenced publication.

Crushing strength will be based upon the AASHTO LRFD Bridge Design Specifications and historical ice / debris conditions at existing structure sites. Engineering judgment should be used to determine the ice crushing strength; if ice and debris are controlling the bent/pier design, contact the Bridge Design Engineer for guidance.

Special ice studies will be conducted for bridges over the Missouri River reservoirs.

For bridge structures, ice loads are applied at a height equal to 2/3 the height from the flowline elevation to HW (100 yr.) as shown on the Hydraulics Data Sheet.

When ice and/or debris conditions may occur at a box culvert site, standard practice is to minimize the number of culvert cells and increase the cell width within reason. Where multiple cells are required, the middle walls are extended to the full length of the apron, sloping the top of the wall from the top of the parapet to the height at the end of the apron as recommended by Hydraulics. No additional analysis is performed on the extended middle walls for ice load.

4.2.3 Materials

Unless otherwise specified, for normal cast-in-place structural concrete, compressive strength at 28 days $f'_c = 4500$ psi and reinforcing steel conforming to ASTM A615 grade 60. Welded wire reinforcement (WWR) conforming to ASTM A1064 grade 75 may be used in precast elements. Stainless steel reinforcing shall conform to ASTM A955 type 2204 or 2205 grade 60.

Stainless steel reinforcing steel is to be used in all state bridge decks, deck supported concrete barriers, and z1 bars extending into approach slabs except as noted below.

Please note that in no instance is stainless steel to be in direct contact with black reinforcing to prevent galvanic corrosion of the black reinforcing steel.

Reinforcing steel extending from substructure units into the superstructure, and approach slab reinforcing is to be epoxy coated. On rural highways with low traffic volumes and on rehabilitation projects reinforcing type will be considered on a case by case basis.

Drilled-in anchors secured with epoxy adhesive are not allowed in sustained tension applications in concrete members.

4.2.4 Box Culverts

4.2.4.1 Barrel Design

When designing reinforced concrete box culvert barrel sections, the current *AASHTO LRFD Bridge Design Specifications* shall be used with the following exceptions:

1. Box Culvert undercut recommendations will be provided by the GEA and the undercut depth will be measured from the bottom of the bottom slab and extended 2 feet larger than the box culvert perimeter. The sides will be sloped at a 1 to 2 (1 foot horizontal to 2 feet vertical). If MSE fabric is recommended the undercut should be lowered at the inlet and outlet to allow fabric to be continuous under the cutoff walls.
2. Use 60 lb./ft.³ equivalent fluid pressure for lateral loads, unless site conditions require a greater load.
3. Distribution Steel: Article 12.11.2.1 of the AASHTO LRFD Bridge Design Specifications requires distribution reinforcement in the bottom of the top slab of box culverts based on a percentage of primary reinforcement. Based on past practice and satisfactory performance of in-service cast-in-place box culvert structures, the AASHTO requirement for distribution steel for the top slab of C-I-P box culverts is waived and distribution steel shall be as follows:

Top and Bottom Slabs: Use No. 4 reinforcing bars spaced at 12" center-to-center. In the inside faces (bottom of the top slab and top of the bottom slab), place the No. 4 bars from edge of fillet to edge of fillet. In the outside faces (top of the top slab and bottom of the bottom slab), alternate No. 4 bars with those in the inside faces.

Walls: Use No. 4 reinforcing bars spaced at 18" center-to-center in both faces. Keep the No. 4 bars a minimum of 3" from the construction joint at the fillets.

4. Design of the barrel sections shall be based on a minimum of 2 ft. of earth cover and include all subsequent fill heights up to and including the maximum fill height, unless the actual fill under the finished roadway is less than 2 ft.; then design for a minimum of 1 ft. of fill. Design for a maximum fill height of 5 ft. when actual maximum fill over the top of the culvert is less than 5 ft. Design fill above the minimum shall increase in 1 ft. increments. Care will be taken to use the appropriate load distribution equations for above and below 2' of fill.
5. Use 1 in. clear cover to all reinforcing steel except in the bottom slab. Use 1 1/2 in.

- clear cover at the top of the bottom slab to account for surface wear in the barrel. Use 2 in. clear cover to the bottom mat of reinforcing steel in the bottom slab.
- The bottom slab of a box culvert will be proportioned to be the same thickness as the top slab unless structural analysis dictates that it be thicker. To account for irregularities in the bedding surface of the bottom slab, 1 in of the 2 in clear shall be neglected, and the reinforcing clear cover set to 1 in from the bottom of the slab in the structural model.

Other standard practices are outlined below:

- All portions of the barrel, including portions not directly under the traffic lanes, are designed for HL-93 to account for backfilling, construction and possible traffic detour loads. Traffic is assumed to pass over the culvert perpendicular to the centerline of the box culvert regardless of the skew of the box.
- When construction loads in excess of legal loads are anticipated, box culvert barrel sections are also designed for a construction vehicle as shown in Figure 4.2.4-1.

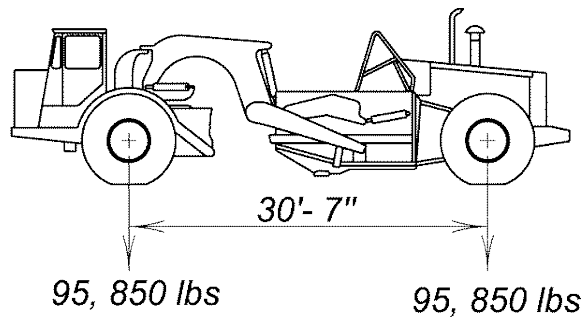

Figure 4.2.4 - 1 Construction Vehicle Configuration

- The construction load is applied using the Strength II Limit State. The construction load is not allowed to cross the structure with less than 4 ft. of fill is in place.
- Longitudinal distribution of the construction load is as per AASHTO. The construction load is distributed transversely through a transverse tire spacing of 7'-6" and a tire footprint width of 33 in. then through the fill as per AASHTO.
- Other construction loads are analyzed on a case-by-case basis.
- Barrel sections are designated according to the amount of earth cover. Where heavier sections are required for fill conditions, barrel design is changed. Barrel sections use an "F" followed by the design fill height for that section (i.e. F6=2-6 ft. fill, F14=2-14 ft. fill etc.) and are designed in increments of 1 ft. of fill.
- Maximum bar size used is no. 8.

8. For constructability (placing and vibration of concrete), minimum wall thickness is 7 in. for rise up to and including 8 ft. For each additional foot in rise, the minimum wall thickness is increased by one-half inch. The minimum top slab thickness shall be greater than or equal to that of the walls, and the minimum bottom slab thickness will equal to the thickness of the top slab. All structural element thicknesses will be proportioned to the minimums outlined in this manual unless structural demand requires them to be increased. Shear in box culverts is taken by the concrete; shear reinforcing is not used.
9. Reinforcing steel spacing shall be in increments of one-half inch with a minimum spacing of 4 in. Maximum bar spacing for main positive moment reinforcement in the top (n bars) and bottom (m bars) slabs and negative moment in the exterior corner joints (k and q bars) is 7 in. Maximum bar spacing for main negative moment reinforcement in the top and bottom (j and s bars) slabs is 7 in. at the center of the joints, and 14 in. beyond where the s bars are no longer needed for capacity. Maximum bar spacing for main reinforcement in the exterior barrel walls (h and k bars) is controlled by design or 12 in., whichever is less. Maximum bar spacing for main steel at interior wall joints (w bars) is limited to 12 in. or that required by design, whichever is less. E bar spacing in the wing heels is limited to that required by analysis or 18 in., whichever is less.
10. Detail 6 in. corner fillets and extend the bottom slab 6 in. beyond the outside face of the exterior wall and use a 6 in. square fillet on top of the bottom slab. An optional square fillet with a 2 in. bevel is also shown on the plans for use at the bottom slab to facilitate forming. See Figure 4.2.4-2.

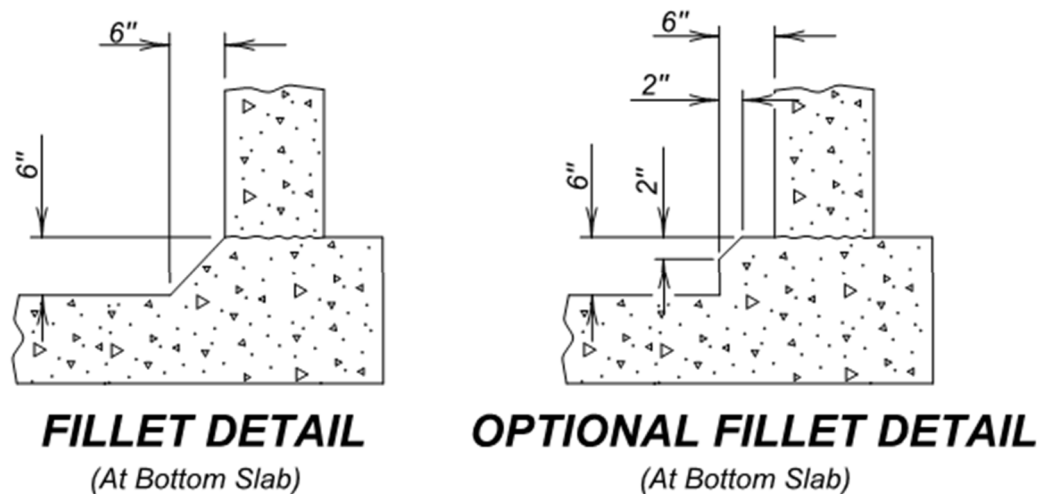

Figure 4.2.4 - 2 Fillet and Optional Fillet Details

11. The bottom of the top slab at the inlet is beveled to improve the hydraulic performance of the box culvert. Minimum bevel is 3 in. for box rises of 6 ft. and below and the

bevel is increased in one-half inch increments with each 1 ft. increase in barrel rise above 6 ft.

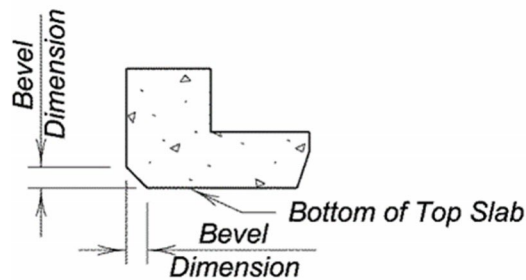

Figure 4.2.4 - 3 Inlet Parapet Bevel Detail

4.2.4.2 Inlet and Outlet Design

4.2.4.2.1 Wing Wall Design

4.2.4.2.1.1 Cantilever Wings

Cantilever wingwalls are designed as cantilever retaining walls using the design wing height equal to the height of the wing at the high quarter point along the length of the wingwall. See Figure 4.2.4-4.

The thickness of the cutoff wall beneath the wing is included in the footing width when sizing the heel, however the volume of concrete in the cutoff wall below the bottom of the heel is ignored in stability calculations.

Heel thickness is taken as the sum of the bottom slab and 6 inch outside fillet. The horizontal heel dimension is sized to keep the resultant soil pressure within the middle one third of the footing. The heel dimension is normally rounded up to the nearest 3 in. for plan details. The full heel dimension is used for the entire length of the wing.

Aprons, when used, are typically built non-monolithic with the wings (separated or debonded from the wings and barrel with preformed expansion joint filler material).

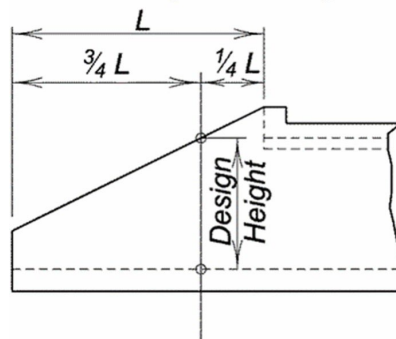

Figure 4.2.4 - 4 Wingwall Design Height

4.2.4.2.1.2 Monolithic Apron and Wings

Monolithic aprons and wingwalls are generally used when the span of the barrel is equal to or less than 7 ft. on single barrel box culverts or when extended middle walls are used at inlets to help pass debris and ice.

Monolithic wingwalls are designed as rigid frames with the walls and bottom slab cast monolithic. The wing wall thickness is kept the same as the barrel wall and the minimum thickness of the bottom slab is generally taken as the wing thickness plus one inch for irregular bedding surfaces. Design height for the walls is taken as the height at the high quarter point of the wingwall. Design span for the bottom slab is normally taken at the low quarter point of the wings. In addition to the final backfilled condition, monolithic inlets and outlets are designed assuming a portion of the soil beneath the bottom slab scoured out. The portion scoured out is taken as the middle 10 ft. or the span of the bottom slab, whichever is smaller. The bottom slab is also checked assuming no backfill adjacent to the wings.

4.2.4.2.1.3 Extended Middle Walls

Extended middle walls are designed monolithic with the bottom slab for C-I-P structures where the box culvert flowline is set at the stream flowline. If a countersunk box culvert flowline is used with riprap aprons, the extended middle walls are founded on their own footings. The height at the end of the extended middle walls is determined by the Hydraulics Program and is based on debris and ice considerations. Design considerations are essentially the same as for other wings, with the middle wall(s) designed for one barrel silted into a height equal to one-half of the barrel rise.

4.2.4.2.2 Drop Inlet or Outlet

Drop inlets may be designed with either monolithic or non-monolithic aprons (monolithic is preferred). When non-monolithic aprons are used, the wings are designed as cantilever retaining walls described above, except the normal fillet at the inside of the wing wall is eliminated. Design considerations for monolithic drop inlets are the same as for monolithic wings.

Drop outlets are designed as monolithic structures similar to monolithic wings described above, with an additional loading consisting of the outlet flowing full and the soil behind the wings scoured out. Where headwalls are used at the end of drop outlets, the headwalls are designed cantilevered off of the wing walls, where feasible, or as cantilever retaining walls assuming the soil in front of the headwalls to be scoured out to flowline.

4.2.4.2.3 Non-monolithic Aprons

Standard non-monolithic aprons are 6 in. thick with a 9 in. thick cutoff wall extending 3 ft.

below flowline. Non-monolithic aprons are reinforced with a single mat of no. 4 bars spaced at 12 in. in both directions placed in the center of the slab. The cutoff wall is reinforced with 5-no. 4 bars running the length of the wall and no. 4 stirrups spaced at 12 inches. Preformed expansion joint material is used between the apron and the adjacent wings and bottom slab.

4.2.4.3 Construction Joints

Transverse construction joints between barrels consist of a 2" x 3" keyway and shall be reinforced in accordance with Standard Plate No. 460.10 Titled *Box Culvert Barrel Tie Reinforcement*.

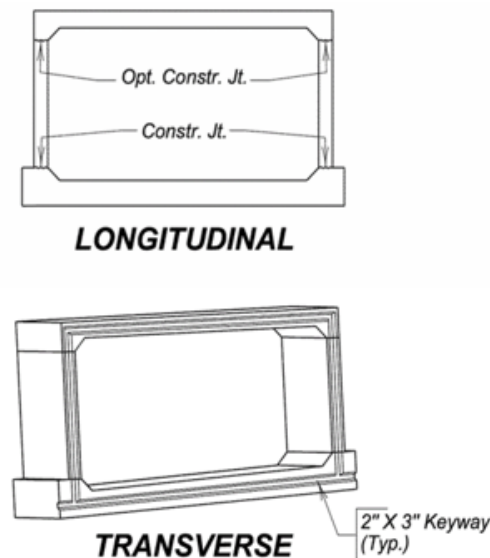

Figure 4.2.4 - 5 Box Culvert Construction Joints

4.2.5 Bridge Superstructures

4.2.5.1 General

The bridge superstructure is defined as the portion of the bridge above the bearing seat or, in the case of integral abutment slab or rigid frame structures, the portion of the bridge that directly supports the driving surface and up (i.e. the slab for a rigid frame or slab bridge).

4.2.5.1.1 Deck Slabs on Girders

Deck slabs on girders are typically designed using Article 4.6.2.1, Approximate Methods of Analysis of the current edition of the *AASHTO LRFD Bridge Design Specifications*, with the following exceptions:

April 2026

1. Clear cover to top reinforcing is set at 2 1/2 inches and bottom reinforcement is set at 1 in.
2. The slab is made composite with supporting girders by stud shear connectors welded to the top flange for steel beams and by extension of the shear reinforcement for prestressed concrete beams. The slab is designed to act compositely for the full length of the span for both steel and prestressed concrete beams.

Other standard practices are outlined below:

1. Minimum beam spacing is approximately 6.5 ft. and maximum beam spacing is limited to 10.5 ft.
2. Slab thickness is based on balanced conditions at service load stresses and, for normal girder spacing above, varies from 8 in. to 9 in.
3. Allowance is made in the reinforcing design for 1/4 in. of wear on the top of the top slab.
4. Stay in place forms are not allowed.
5. Straight transverse reinforcing steel placed perpendicular to the girder centerlines is utilized for main slab steel. No truss or “crank” bars are allowed. No. 5 bars are used for top transverse reinforcement and no. 5’s alternating with no. 4’s are used in the bottom. The bottom no. 5’s are cut off just beyond the exterior girder centerlines. Additional reinforcement may be required in the top of the slab in the cantilevers to handle excessive cantilever loads (barrier supported sidewalk, etc.).
6. Top longitudinal reinforcement consists of no. 5 bars spaced 12 inches on center from curbline to curbline, and for continuous spans, the number and/or size is increased in the negative moment region at the bents as required for the particular supporting girder design. Bottom longitudinal reinforcement is no. 5 bars spaced between edges of girder flanges as required to satisfy distribution reinforcement provisions of the *AASHTO LRFD Bridge Design Specifications*.

Continuous slabs placed on girders (whether placed full width or in phases) should be checked to ensure that the concrete remains plastic in regions where the slab may be in tension during placement of the deck concrete elsewhere on the structure. A plan note is used to specify a rate of placement of deck concrete (expressed in feet of deck per hour along centerline roadway) that will prevent deck concrete from reaching initial set and experiencing tension in any section or region during placement for the full deck length.

To calculate the maximum rate that the finish machine is capable of finishing, the following assumptions are used:

1. The rollers (with the carriage) travel at 80 ft./min. transverse to the machine.

April 2026

2. The rollers finish in both directions for 0° skewed structures and only in one direction for skewed structures.
3. The finish machine travels 9 inches per finishing pass along the centerline of the roadway regardless of the skew of the structure.

To calculate the minimum rate that concrete can be placed, the following assumptions are used:

1. Normal concrete remains plastic for 2 hours.
2. For steel girder structures, concrete placed beyond the far point of dead load contraflexure (0.75 span pt.) in a span does not cause tension in the slab at the support near the beginning of a span. Therefore, concrete must remain plastic from the pt. of dead load contraflexure (0.75 span pt.) of one span, over the support and to the far point of dead load contraflexure (0.75 span pt.) in the next span. The same requirements are used for prestressed girders made continuous for live load.

The maximum rate that concrete can be delivered to the deck is taken as 80 yd.³/hr. If the minimum rate required for the concrete to remain plastic in the tension regions is greater than this, or if the finish machine cannot finish at the minimum rate required, then staged deck pours, a longitudinal deck joint or admixtures to delay the initial set of concrete must be used.

When staged deck pours are required, office practice is to pour the positive moment regions first, then pour the negative moment regions. Plans are usually set up for numbered pours in each of the regions and the Contractor is allowed to combine the positive moment pours into one pour sequence and the negative moment pours into one pour sequence. Construction joints between pours are made with keyways if required by calculation.

When the rate of pour does not affect the structure (i.e. simple spans, slab bridges, temporary supports etc.) a minimum rate of 40 yd.³/hr is used.

4.2.5.1.2 Bearings

All bearings, whether fixed or expansion, are set on grout pads. The grout pads are recessed into the substructure 1 1/2 in. and sized in plan to be 2 in. larger (1 in. in each direction) than the bearing masonry plate or elastomeric bearing pads. Minimum grout pad height above the supporting surface is 1 1/2 in. and maximum height above the supporting surface is 6 in. Where the grout pad would project above the supporting surface more than 6 in. the supporting surface may be stepped, or alternately, the grout pad may be reinforced.

Plain elastomeric pads are used for fixed bearings with integral cast-in-place diaphragms on prestressed girder bridges. The width of the pad is set equal to the width of the bottom flange of the girder less the 1 in. chamfer on each side of the bottom flange. The pads are designed for the dead load reaction of the girder, slab, diaphragms and barriers only; live

load and any future overlay is assumed to be distributed through the cast in place diaphragms to the substructure unit.

Reinforced elastomeric pads with steel rocker plates are generally used for expansion bearings on prestressed girder bridges. The width of the steel rocker plate is set equal to the width of the bottom flange of the girder less the 1 in. chamfer on each side of the bottom flange. The width of the elastomeric pad is set equal to the width of the steel rocker plate less 2 in. The reinforced elastomeric pad is designed for the movement of the superstructure using the AASHTO cold temperature range. A bearing plate is used between the elastomeric pad and the rocker plate and is sized in plan dimensions to be 2 in. larger in all directions than the elastomeric pad. The elastomeric pad is set directly on the grout pad. To provide for transverse support, structural angles are bolted through the grout pad.

Steel rocker plates with steel sole plates and masonry plates are used for fixed bearings on steel girder bridges. Normal practice is to design the rocker plate with a radius of 18 in. for bearings at bents or piers and a radius of 12 in. at abutments. The masonry plate is set on a 1/8 in preformed fabric pad on top of a grout pad. The rocker plate is bolted to the sole plate which has been shop welded to the bottom flange. Slotted holes are provided in the sole plate to allow for construction tolerances and erection temperature. See Figure 4.2.5-1 for details.

Steel rocker plates with sole plates, masonry plates and stainless steel and Teflon sliding plates are generally used for expansion bearings on steel girder bridges. The sole plate is set equal to the width of the bottom flange plus 1 in. and the stainless steel plate welded to the sole plate is set at the same width as the bottom flange. The length of the sole plate and stainless steel plate is calculated using the AASHTO cold temperature range with an additional length of 3 in. added to each end of the plates for construction tolerances and erection temperature differences from an assumed erection temp. of 70° F. The width of the Teflon is 1 in. less than the width of the stainless steel sliding plate. The Teflon is recessed into the rocker plate 3/32 in. Steel keeper bars are used to handle any transverse loads. Stainless steel plates are provided on the sides of the sole plate and Teflon is bonded to the keeper bars. A gap of 1/8 in. is left between the keeper plates and the sole plate.

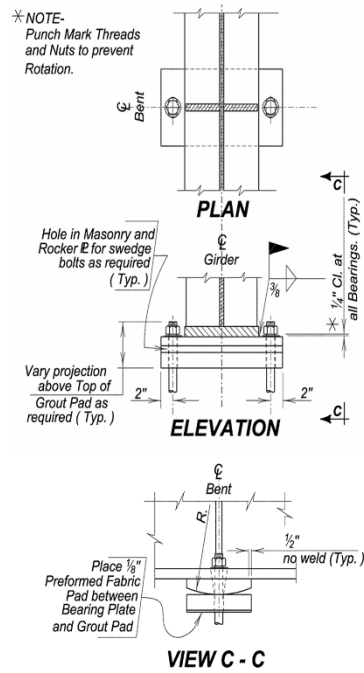

Figure 4.2.5 - 1 Steel Girder Fixed Rocker Bearing

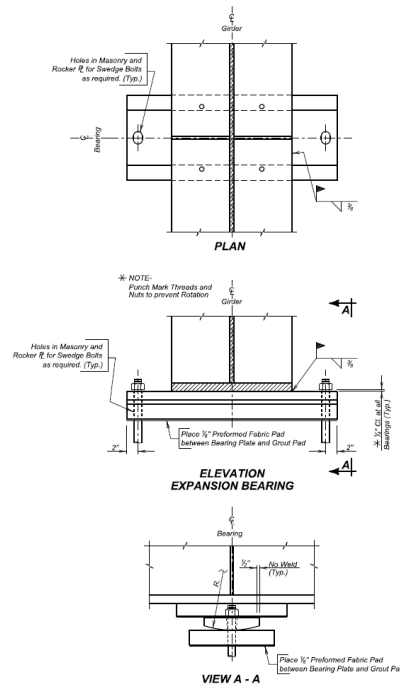

Figure 4.2.5 - 2 Steel Girder Expansion Rocker Bearing

4.2.5.1.3 Expansion Devices

For integral abutment structures, expansion devices are provided at the end of the

reinforced concrete approach slabs. Standard practice is to use a membrane sealant expansion joint between the approach and sleeper slab designed for movement based on temperature. Normal practice is to use a 3 in. gap at an assumed installation temperature of 70° F. However, this dimension should be checked to ensure a minimum joint width for installation of 1 1/2 in. at an assumed maximum installation temperature of 90° F. If needed, the 3 in. dimension can be adjusted.

For structures with sill type abutments, expansion devices are used at the abutment. The type of expansion device is dependent upon the overall movement of the structure at the abutment. Expansion device by type and structure movement are shown in Table 4.2.5-1.

Table 4.2.5-1

MOVEMENT AT ABUTMENT	EXPANSION DEVICE TYPE
< 4"	Membrane Sealant/Vseal
4" to 8"	Finger joint with neoprene seal
> 8"	Modular Joint

The plates in a finger joint are designed for movement using the AASHTO cold temperature range. A minimum gap between the end of the girders and the abutment backwall as well as in the expansion device of 1 1/2 in. is required at 90° F.

The gap in the concrete barrier at the expansion joint is left open if the maximum gap is 4 in. or less. Gaps larger than 4 in. are considered a "snag" point and are protected by sliding plates over the gap. Minimum thickness for the sliding plates is 1/2 in. Large gaps may require thicker plates to adequately span the gap.

4.2.5.1.4 Sidewalks/Shared Use Paths

Where a sidewalk or bike path extends over a box culvert, the culvert is extended to provide adequate length for the sidewalk as shown in the roadway typical section.

On bridge structures, 5'- 0" clear sidewalks are normally cantilevered off of the back of the barrier with an additional width of 10 in. to allow for railing and 8'- 0" or wider shared use paths are normally made part of the deck with an additional width of 10 in. for railing. Any gap at an expansion joint must be 2" or less to meet ADA requirements. If 2" cannot be maintained a sliding plate expansion device must be used to cover the joint.

4.2.5.1.5 Railings

4.2.5.1.5.1 Bridge Rail

Normal practice is to use a Single Slope barrier on all new bridges on the state highway trunk system. Exceptions to this practice include bridges on scenic highways where an open type of rail faced with timber or “Kansas Corral” type rail is used for aesthetics and situations where one of a twin set of bridges is being replaced in which case a matching rail may be used. Rail types for approach road structures are determined on a case-by-case basis considering landowner wishes (if applicable), economics and safety requirements. Standard end blocks are provided with single slope barriers to allow for attachment of either thrie beam or 3 cable guard rail.

When sill type abutments are used, a portion of the end block is cantilevered off of the abutment backwall. The section at the expansion joint is normally rectangular in shape with a transition to rectangular located on the structure. The bridge approach rail is attached to the portion of the end block cantilevered off of the abutment backwall.

Barrier Concrete per linear foot		
ITEM	UNIT	QUANTITY
Barrier	Cu. Ft.	3.46

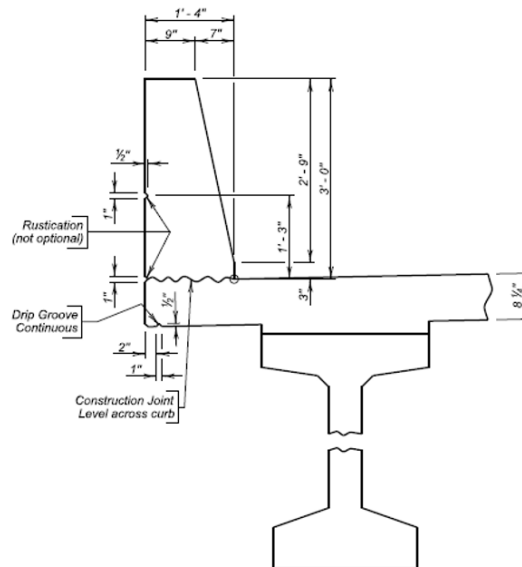

TYPICAL BARRIER SECTION

Figure 4.2.5 - 3 Single Slope Concrete Bridge Rail

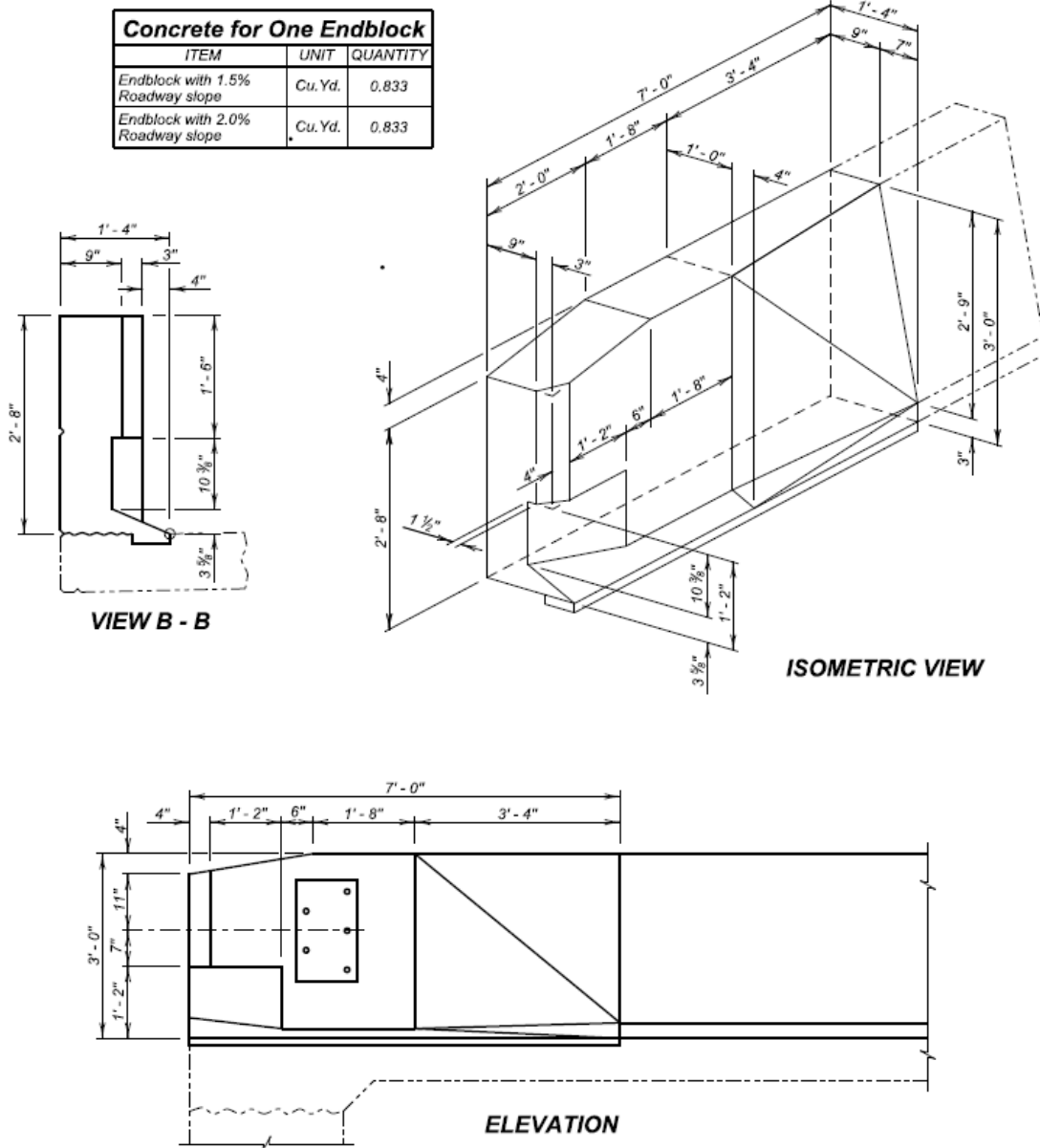

Figure 4.2.5 - 4 Single Slope Concrete Bridge Rail End Block

Results of Pooled Fund Project TPF-5(193) Supplement 151 provided a Mash Test Level 4 open Concrete rail shown in Figure 4.2.5-5. Refer to the Pooled Fund Project for design information.

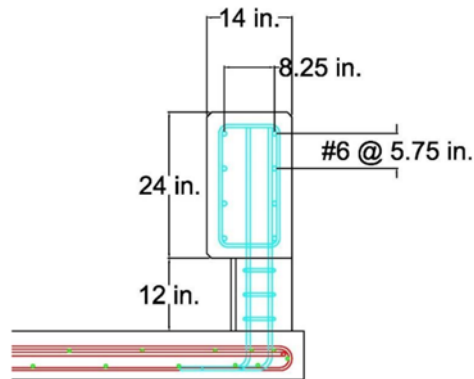

Figure 4.2.5 - 5 Open Concrete Bridge Rail

4.2.5.1.5.2 Pedestrian/Bike Path Rail

All design geometry and loading for new pedestrian and bicycle railing on structures shall be in accordance with the *AASHTO LRFD Bridge Design Specifications* current at the time of project railing design initiation. Railing design shall also be compliant with Americans with Disabilities Act requirements.

A railing height of 42" measured from the top of walkway should be used for bridge pedestrian and shared use paths less than 8' wide (clear width). For paths 8' wide or more (clear width) and for designated bikeways on bridges, a 54" height railing should be used.

Generally, walkways/paths incorporated on vehicular bridges should be separated from the roadway by combination railing. Unless design conditions prevent it, the combination rail height should match the walkway/path outside rail height above the top of walkway.

On grade separation structures spanning over public roads, the outside railing may incorporate an 8' high (measured from the top of walkway) curved extension, above the normal top of railing, to hinder objects being dropped or thrown onto traffic lanes below. For highway over railroad grade separations, outside railing may also incorporate similar protection details if requested by the operating RR.

The top horizontal railing element (42" or 54" high) should be designed continuous and smooth with no post protrusions or other attachments above top of rail (except in grade separation cases with rail extensions as described above).

A railing height of 42" measured from the top of parapet or wing should be used for box culvert mounted installations adjacent to pedestrian, shared use or bicycle paths. Railing shall be carried on top of the parapet and wings down to a point where the vertical drop from top of wing to flow line is 30" or less.

A railing height of 42" measured from the top of walkway should be used on retaining walls over 30" in height adjacent to and below pedestrian, shared use or bicycle paths.

Normal practice for bridge structures is to use a steel tube rail faced with chain link fence, to meet opening requirements, on the outside of the sidewalk or bike path and a single slope barrier topped with steel tube rail separating the pedestrian and bike traffic from the roadway traffic on the inside of the sidewalk or bike path. For railings over box culvert structures, standard practice is to use the same type of steel tube railing faced with chain link fence.

4.2.5.1.6 Deck Drains

Deck drains are used when they are required to limit the spread of deck drainage into the roadway. The number and maximum spacing of deck drains is determined in accordance with the *South Dakota Drainage Manual*.

Standard deck drains for slab type bridges are 4 in. diameter PVC tubes through the deck with a slight depression formed in the concrete surrounding the tube as shown Figure 4.2.5-2 and Figure 4.2.5-3.

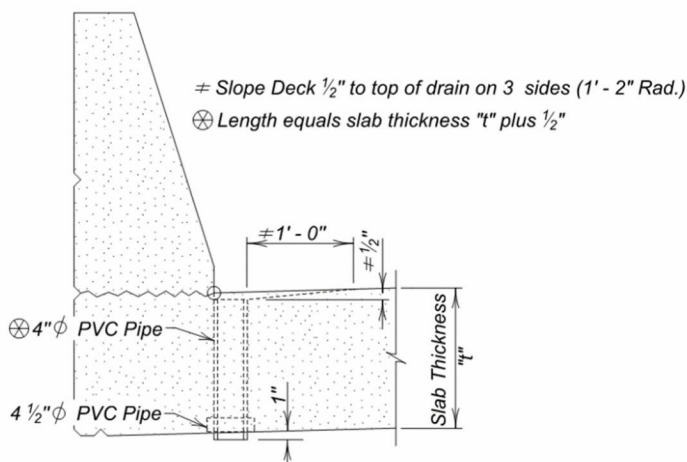

Figure 4.2.5 - 6 Deck Drain Detail Continuous Concrete Bridge

Standard deck drains for girder type bridges are 4 in. diameter fiberglass drop tubes extended to a minimum of 12 in. below the bottom of the exterior girder unless free board is less than 2 feet then reduce to 6 inches. The tubes are braced as shown in the following detail. The concrete deck immediately surrounding the drop tube is depressed slightly to facilitate drainage as shown in Figure 4.2.5-3. Prestressed girder shown; steel girders similar. Supports for steel girders will use a steel with the same mechanical properties as the web of the girder and will be bolted with a fully tensioned ASTM 3125 Gr. 325 bolt.

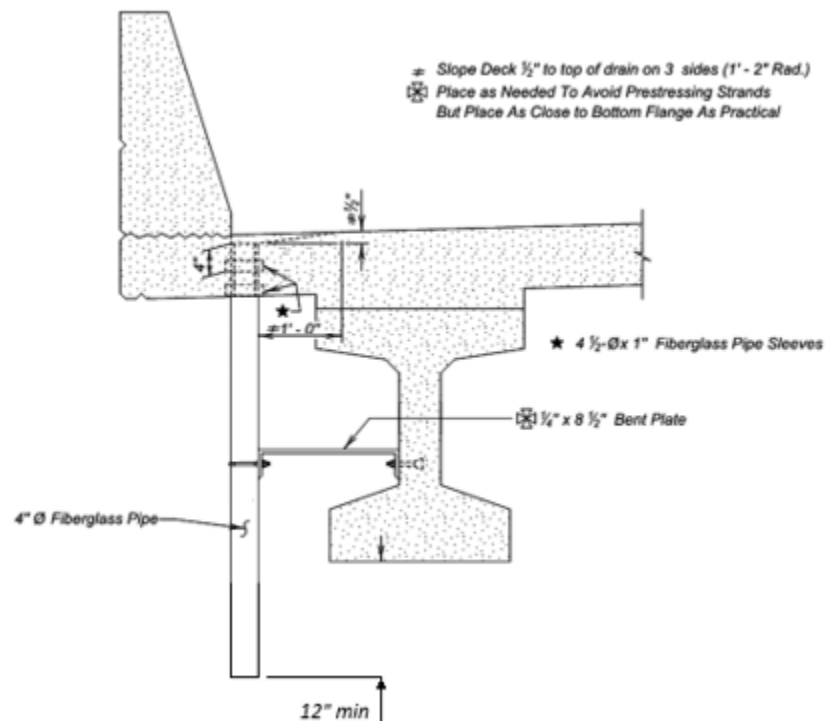

Figure 4.2.5 - 7 Deck Drain Details, Girder Bridge

4.2.5.1.7 Utilities and Lighting

When required, provision is made to attach utility conduits and lighting to bridge superstructures. Utility conduits are generally attached to the underside of the superstructure to line up with the utility off the end of the bridge. See *Administrative Rules of South Dakota* for utility attachment details. Sleeves are normally provided through abutments, diaphragms, and bridge end backfill to prevent damage to the conduit.

All attaching hardware that is embedded into the deck or other portions of the structure concrete shall be stainless steel or other approved corrosion resistant material.

Where roadway lighting is required across bridge superstructures, the poles are supported on standard supports provided behind the bridge rail.

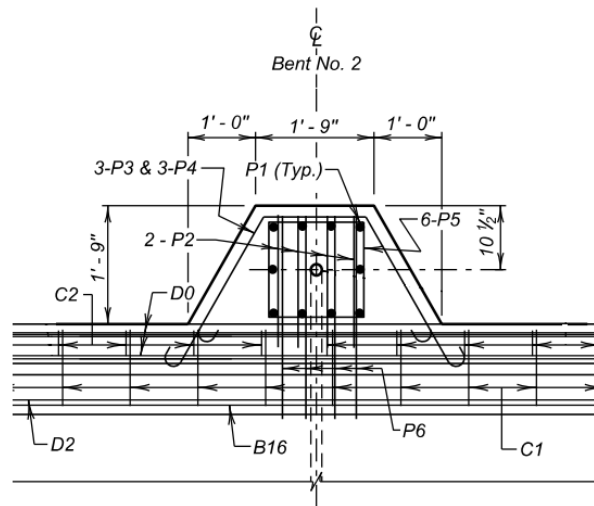
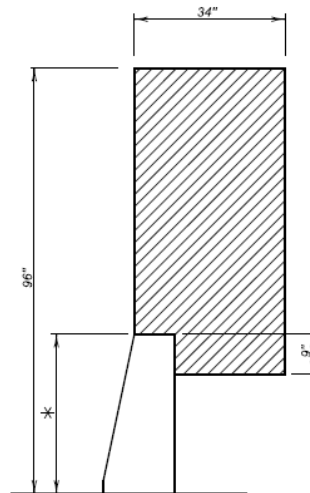

Figure 4.2.5 - 8 Pole Support on Bridge Rail

For all attachments not under the ownership or operation of the state a utility attachment permit is required.

4.2.5.1.8 Sign Supports

When required, provision is made to attach roadway signing to bridge superstructures. The preferred method of attachment is to bolt the sign directly to the back face of the concrete barrier this is not allowed on pedestrian rail or a sign that will be higher than the barrier. A bracket is fabricated and attached to the edge of the superstructure and the bridge girders (if any). The sign bracket must be a minimum of 9 inches below the top of barrier and the shy distance from the top front edge of the barrier to the sign or sign support structure will be a minimum of 34 inches. See Figure 4.2.5-8 for details.



* Review TL-4 barrier heights fall in a range of 29" to 42".

Figure 4.2.5 - 9 Sign Support Bracket Shy Distance

4.2.5.1.9 Stream Gaging Stations

When required, provision is made to attach stream gaging equipment for the United States Geological Survey. Details for equipment to be attached and attachment requirements are obtained from the United States Geological Survey.

For all attachments not under the ownership or operation of the state a utility attachment permit is required.

4.2.5.2 Concrete Slab Superstructures

Three slab configurations are used for continuous concrete slab bridges: haunch flat slab (drop panel), parabolic haunch slab, and flat slab bridges as shown in Figure 4.2.5-10 through Figure 4.2.5-12. A flat slab type bridge is most commonly used; however, a parabolic haunch slab is utilized where aesthetics is determined to be an important factor and where added stiffness is needed at the joints of rigid frame type slab bridges.

When designing continuous concrete slab bridges, the current *AASHTO LRFD Bridge Design Specifications* will be used with the following exceptions:

1. Slab thicknesses are proportioned by limiting the live load deflection in any span to $L/800$ and $L/1000$ (w/sidewalk). Use the gross moment of inertia for the live load deflection calculations. Refer to the AASHTO 9th edition or earlier LRFD Bridge Design Specification.
2. Wind loads and all longitudinal loads are assumed to be transferred to the abutments by the stiffness of the slab. These loads are not considered when designing the slab or bents/piers.

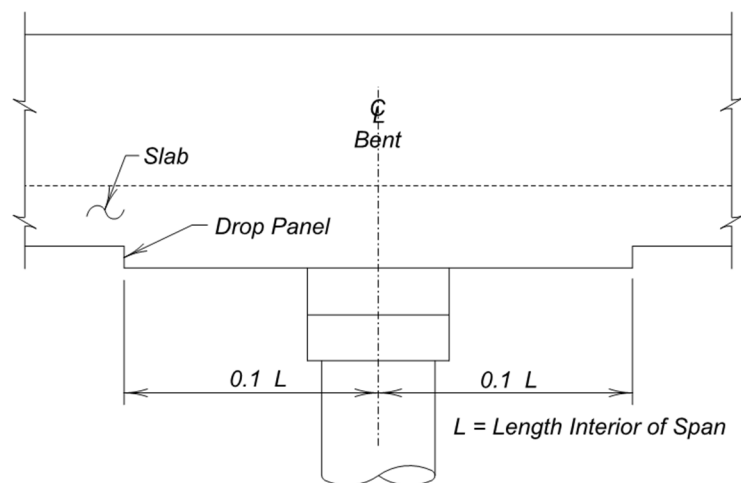

Figure 4.2.5 - 10 Drop Panel Haunch Continuous Concrete Bridge

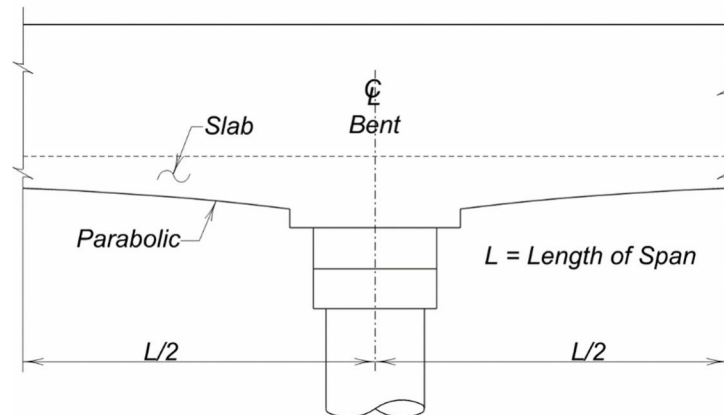

Figure 4.2.5 - 11 Parabolic Haunch Continuous Concrete Bridge

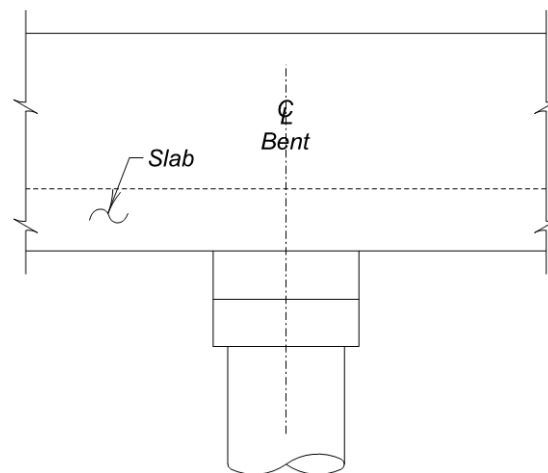

Figure 4.2.5 - 12 Flat Slab Continuous Concrete Bridge

Other standard practices are outlined below:

1. Span ratio is kept at 1.25:1 to optimize slab thickness for bending moment and keep dead load moment induced into intermediate supports to a minimum.
2. For haunch slabs, the ratio of the first moment of inertia of the gross concrete slab section at the haunch region (maximum slab thickness) to that at the positive region (minimum slab thickness) is kept very near 2.5. For haunch flat slab type, the length of the drop panel is set at one tenth of the interior span length on both sides of the support. For parabolic slab type, the parabola typically begins at midspan and extends to the interior support (extends both directions for interior spans).
3. For a flat slab, the slab thickness in the positive region of the interior span/spans is

normally kept the same as that in the end span.

4. Rigid frame structures normally employ a parabolic slab with the haunch depth approximately twice the minimum slab thickness.
5. Allowance is made in the design for 1/4 in. of wear on the top of the deck slab surface.
6. Reinforcing steel cut off points are determined by satisfying capacity, fatigue and flexural cracking requirements as specified by AASHTO with the appropriate extension as well as providing adequate development beyond critical sections.
7. Distribution reinforcement shall be taken as a minimum of 30% of the effective main positive moment reinforcement for each span. This policy was adopted based on results from a study conducted by Dr. Iyer at the South Dakota School of Mines and Technology titled *Load Capacity of Older Continuous Concrete Slab Bridges*.
8. Structures skewed from 20 degrees to 35 degrees are designed for the span length perpendicular to the supports. The required area of steel is determined as if the slab were straight then multiplied by the secant squared of the skew angle to account for the reinforcing steel being placed parallel to the centerline of the roadway (the effective area of steel acting in the direction perpendicular to the supports is the actual area in the direction along centerline divided by the secant squared of the skew angle). For skews beyond 35 degrees, other types of superstructures are recommended.
9. Longitudinal edge beams are designed in accordance with AASHTO. The design span length is taken as the length parallel to the centerline of roadway between supports. If sidewalks are provided, sidewalk dead and live loads are assumed to be taken solely by the edge beam. Live load moment from vehicular traffic resisted by the edge beam is taken as specified in the AASHTO Specifications unless a mountable curb with cantilever sidewalk and combination railing is used. In this instance, with one wheel on the sidewalk and one near the curb, the edge beam is assumed to take the full axle load in addition to the sidewalk and edge beam dead load (for this case, some additional width of slab may be included as edge beam if required).
10. Cantilever sidewalks are designed as cantilever slabs with pedestrian loading or concentrated wheel loads (if used with mountable curb and combination railing) as specified in the AASHTO Specifications using whichever load results in the most critical condition.

4.2.5.3 Prestressed Girder Superstructures

When designing prestressed girder bridges, the current *AASHTO LRFD Bridge Design Specifications* shall be used with the following exceptions:

1. Live load deflections are limited to $L/1000$ and $L/1200$ (w/sidewalk).
2. The maximum allowable tensile stress in the bottom fiber of the girder under HL-93 Service III loading shall be zero for Interstate and heavy truck traffic routes, and $0.0948\sqrt{f'_c} \leq 0.3$ (ksi) for all other structure locations. In special cases and with permission from the Bridge Design Engineer, the tension in the bottom fiber of the girder may be increased to $0.19\sqrt{f'_c} \leq 0.6$ (ksi).

Other standard practices are outlined below:

1. Maximum 28 day compressive strength of girder concrete f'_c shall be 7000 psi. Concrete strengths in excess of 7000 psi may be used with the approval of the Bridge Design Engineer. Minimum initial compressive strength of girder concrete f'_i shall be 4500 psi and increased as required in 100 psi increments.
2. Seven wire 0.6" nominal diameter type 270 k low relaxation strands conforming to AASHTO 203 are used for prestressing steel.
3. The preferred practice is to design prestressed girder bridges simple span for non-composite dead loads and continuous for live load and composite dead load with a span ratio to balance the strand requirements (usually between 1.05:1 and 1.1:1). See items below for limitations and guidance.
4. Girders are designed to be composite with the slab which has an f'_c of 4500 psi. The effective flange width used in the computation of composite section properties is adjusted by the ratio of the slab and girder concrete moduli of elasticity. For continuous designs, a constant composite beam moment of inertia is assumed for the full length of the bridge.
5. When skews are 35 degrees or less and the factor of safety against cracking over the intermediate supports under service loading is greater than 1.2, multiple span girder bridges are designed to be continuous for live load and composite dead load. The girder ends are placed on temporary elastomeric bearing pads, set 9 in. apart over the intermediate supports and are encased in an integral diaphragm. The bottom row of prestressing strands is extended and bent up into the diaphragm. Mild reinforcing steel is placed in the slab over the intermediate supports to make the upper negative moment continuity connection.
6. If skews are 35 degrees or less, but the factor of safety against slab cracking over the intermediate supports under service loading is less than 1.2, the girders are conservatively designed as simple spans for all loads. The girder ends are placed

on temporary elastomeric bearing pads, set 9 in. apart over the intermediate supports and are encased in an integral diaphragm. The bottom row of prestressing strands is extended and bent up into the diaphragm. Mild reinforcing steel is placed in the slab over the intermediate supports to make the upper negative moment continuity connection.

7. At integral abutments, girder ends are placed on temporary elastomeric bearing pads overhanging the centerline of the pile cap 1 1/2 in. and are encased in an integral abutment backwall. The bottom row of prestressing strands is extended and bent up into the abutment backwall.
8. When skews exceed 35 degrees, girders are designed as simple spans, and the ends are not encased in an integral diaphragm. Girder end blocks are normally used in this situation.
9. Beam ends are squared off on skewed structures to avoid stress concentrations.
10. Maximum spacing for vertical shear web reinforcement shall be 18 in.
11. Long term camber and deflection (used for determining girder haunches and slab form elevations) is calculated using the multipliers as described in Chapter 8 of the *PCI Bridge Design Manual, 3rd Edition*. Based on past results, the multiplier for upward camber at erection is taken as 1.80.
12. Midspan steel diaphragms are utilized. By plan note the Contractor is required to install the midspan diaphragms in conjunction with girder erection to provide support for girders prior to placing the slab.
13. Strand pattern will be determined by the designer and under no circumstances is to be left to the fabricator to determine. When required to reduce stress at the beam ends, strands are linearly draped (harped) through the web. Typically, the hold down(harp) points are located approximately 1/10 of the span length from side of the centerline of the beam. Approximately 1/3 the total number of strands are typically draped. Debonding of strands near beam ends is generally not allowed but if necessary and with permission from the Bridge Design Engineer debonding may be allowed.
14. Standard Shape girders are normally used. See Figure 4.2.5-13 to Figure 4.2.5-18 for details. With special permission from the Bridge Design Engineer other "I" shapes may be allowed, provided the availability of forms with local precast facilities is verified.

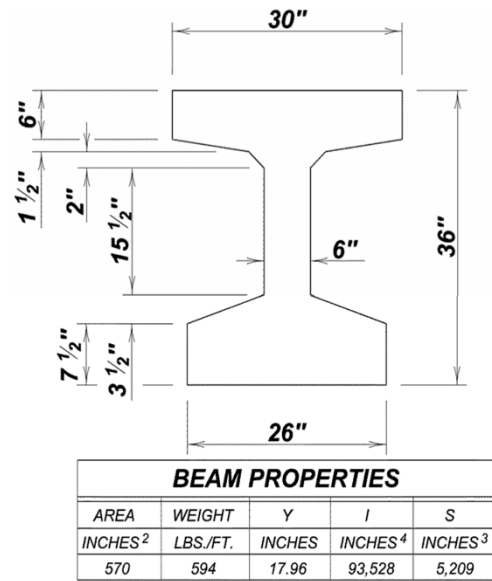

Figure 4.2.5 - 13 36M Prestressed Girder Properties

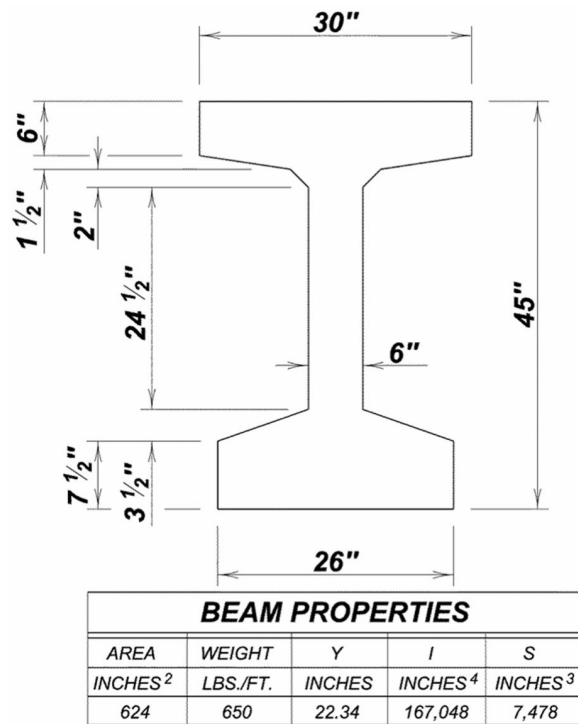

Figure 4.2.5 - 14 45M Prestressed Girder Properties

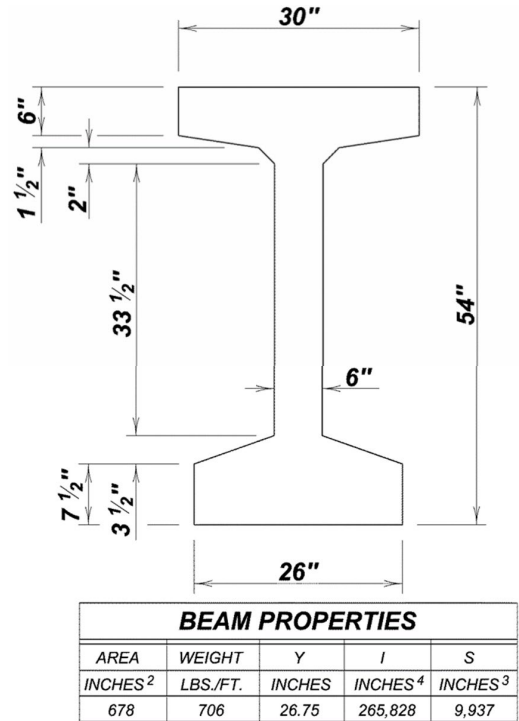

Figure 4.2.5 - 15 54M Prestressed Girder Properties

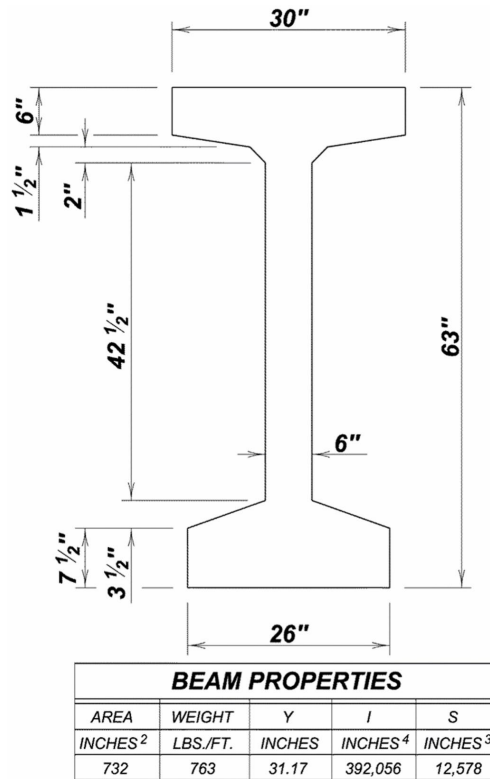
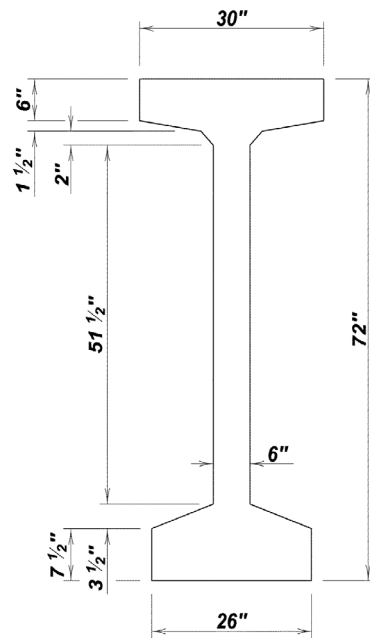
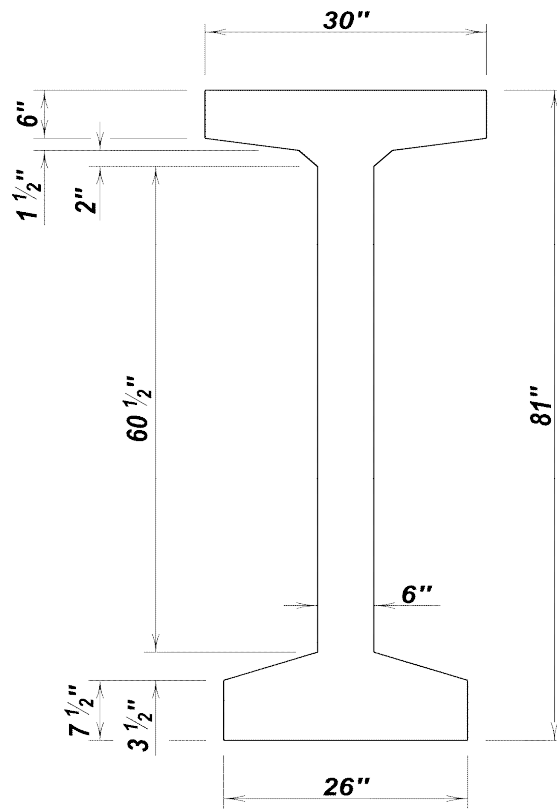

Figure 4.2.5 - 16 63M Prestressed Girder Properties



BEAM PROPERTIES				
AREA	WEIGHT	Y	I	S
INCHES ²	LBS./FT.	INCHES	INCHES ⁴	INCHES ³
786	819	35.60	547,922	15,391

Figure 4.2.5 - 17 72M Prestressed Girder Properties



BEAM PROPERTIES				
AREA	WEIGHT	Y	I	S
INCHES ²	LBS./FT.	INCHES	INCHES ⁴	INCHES ³
840	875	40.04	735,615	18,372

Figure 4.2.5 - 18 81M Prestressed Girder Properties

4.2.5.4 Steel Girder Superstructures

When designing steel girder bridges, the current *AASHTO LRFD Bridge Design Specifications* shall be used except that live load deflections are limited to $L/1000$ and $L/1200$ (w/sidewalks).

Other standard practices are outlined below:

1. Normal practice is to use continuous composite welded plate girders with a span ratio of 1.25:1, however, span length, allowable superstructure depth and economic criteria may result in the use of other types of steel girders.
2. ASTM A709 Gr. 50 weathering steel is generally used. Where aesthetics is a concern for weathering steel structures, the outside face and the bottom of bottom flange of the fascia girder may be painted. Structures over high speed roadways where salt spray is a concern and structures over waterways with limited freeboard at the 100 yr. high water elevation are designed using painted A709 Gr. 50 or 70

steel. Hybrid girders, using Grade 70 steel, are considered for long span (spans > 200 ft. or so) continuous steel structures. Steel for stiffeners, diaphragms and other secondary attachments may be ASTM A709 Gr. 36 at the option of the fabricator. Main load carrying members are required to meet Charpy requirements in temperature range T2 for structure locations south of Highway 20 and T3 for structure locations on and north of Highway 20.

3. Parallel flange girders are preferred. Where site conditions or aesthetics dictate, haunch girders may be used, with permission of the Bridge Design Engineer. Standard haunch configuration is as shown:

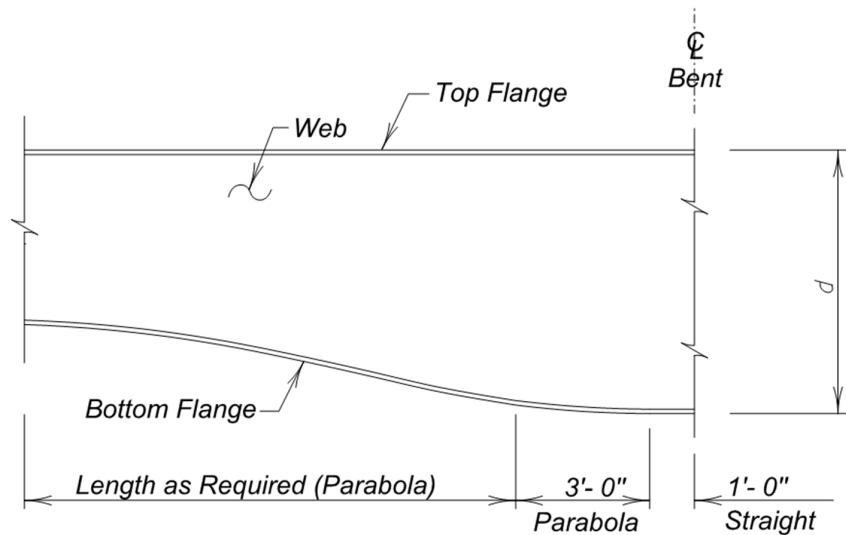

Figure 4.2.5 - 19 Parabolic Haunch Steel Girder

4. Steel girders are designed continuous over the interior supports for both dead and live loads. Composite action is assumed the full length of the structure.
5. Steel girders are designed for Fatigue Limit State I, including shear connectors.
6. Office practice plate size requirements are as follows:

Minimum web “t” = 3/8”. Size web thickness to provide minimum transverse stiffeners. Longitudinal stiffeners will be avoided for spans less than 250’; for spans greater than 250’ longitudinal stiffeners should be considered for economics.

Maximum flange “t” = 2”. Minimum top flange in the positive moment region is 14” x 3/4”

Cover plates are NOT used.

Web and flange plate increments are as follows:

Web depth is in 3" increments.

Web thickness is in 1/16" increments; minimum 3/8".

Flange thickness is in 1/8" increments; minimum 3/4".

Flange width is in 1" increments. Changes in flange width should be avoided, if possible, to aid in slab forming and splice construction.

Minimum filler plate thickness 1/8".

7. When a flange thickness or width is changed at a welded shop splice, transitions in the both the thickness and width will designed to provide proper flow of stresses through the transition.
8. Standard transverse stiffener size is 5" x 3/8". Diaphragm stiffeners are 6" x 3/8". By plan note, stiffener "t" may be increased to web "t".
9. Standard practice is to assume a loading of 35 lb./ft. for attachments (stiffeners, diaphragms etc.) Where lateral bracing is required, this number should be checked for adequacy.
10. Girder splices are designed as slip critical connections. Standard practice is to use 7/8" dia. F3125 Gr. A325 bolts with direct tension indicators. Faying surfaces are painted with one coat of primer and the slip resistance is taken as Class B. See Figure 4.2.5-21 for standard splice details and Figure 4.2.5-22 for direct tension indicator details. Faying surfaces for weathering steel will be abrasive blasted and left bare with no primer.

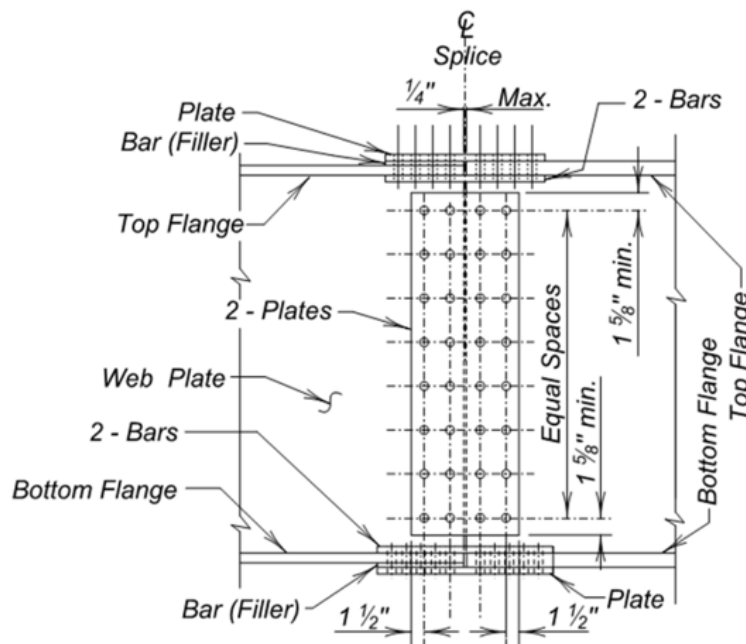

Figure 4.2.5 - 20 Bolted Field Splice Detail

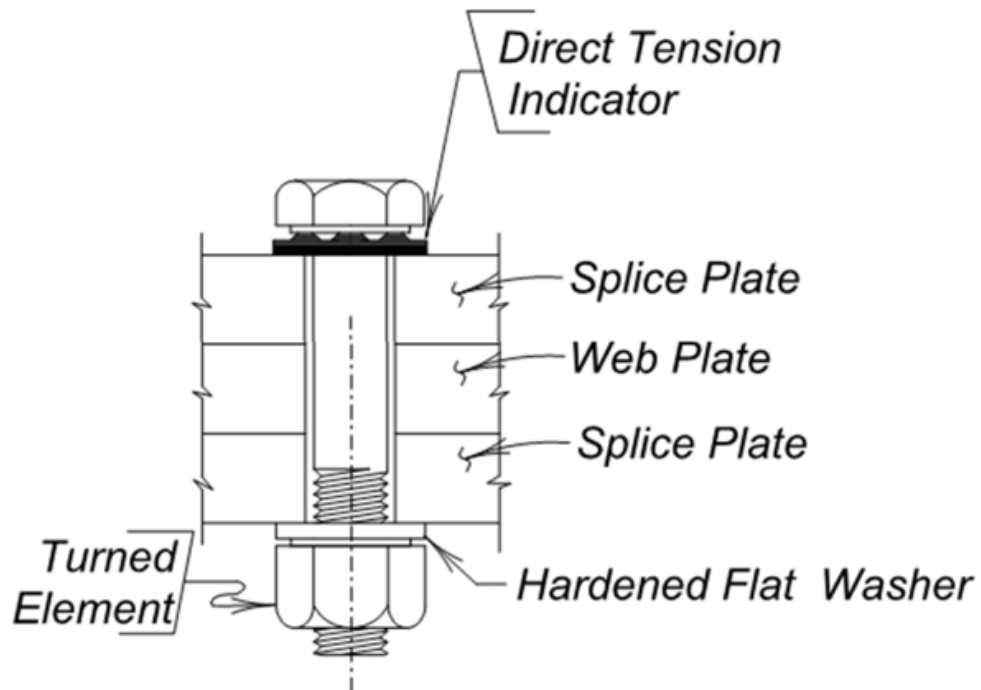

Figure 4.2.5 - 21 Direct Tension Indicator Details

11. Composite action is achieved using end welded anchor studs. Standard practice is to use 7/8" studs in rows of 3 or more depending upon AASHTO code requirements and top flange widths. A minimum edge distance of 1 1/2" is maintained. See Figure 4.2.5-22 for details.

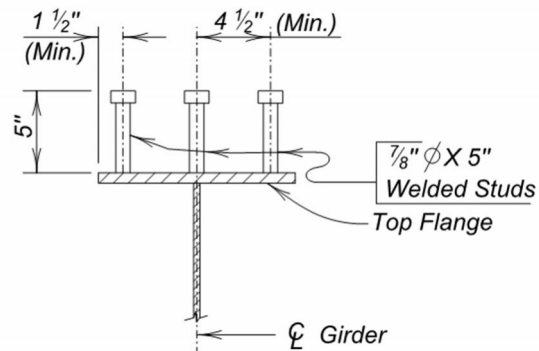

Figure 4.2.5 - 22 Shear Stud Connection Detail

12. For web depths of 48" or less, bent plate diaphragms are used. When the web depth exceeds 48" "K" brace diaphragms with top struts are used. Diaphragms are placed "in-line" when the bridge skew is 20° or less. When the skew is greater than 20°, the diaphragms are placed normal to the girder centerline. As part of the superstructure design, a torsional analysis of the exterior steel girders for

construction loading shall be completed. Girders under 3 feet in depth will use needle beam false work so rotation from construction loading need not be checked. The analysis should be based on the following assumptions:

- The concrete bridge deck cantilever slab formwork will be constructed using prefabricated steel overhang brackets (w/o needle beams)
- Finish machine rail loads are also to be supported on the overhang brackets using a 2500 lb effective point load 0.125 feet beyond the edge of the deck.
- The overhang bracket spacing will be 3 feet and the length of the top cord of the overhang bracket will be the length of the deck overhang plus 2.5 feet for the walk way and forms. The diagonal leg will be from the middle of the walkway to 0.5 feet above the bottom flange of the girder. A live load of 50 psf will be applied to the walkway and a concrete and form dead load of 160 pcf plus 50 psf live load will be applied to the deck overhang along with a 75 plf load at the edge of the deck.
- Total lateral deflection limit of 0.25" at any point along the girder top flange

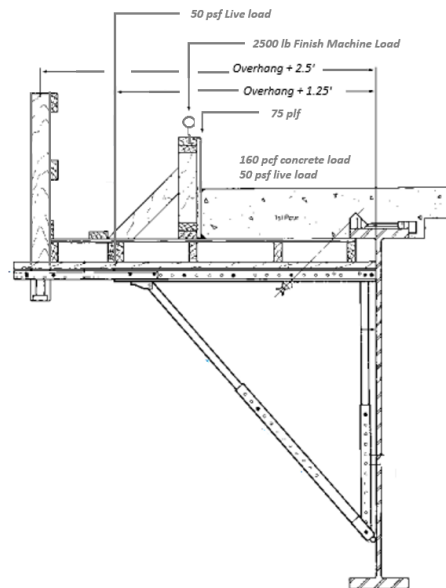

Figure 4.2.5 - 23 False Work Overhang Bracket

If the torsional analysis indicates that temporary lateral bracing (between diaphragms or cross frames) will be needed, notes to cover the associated contractor falsework submittal requirements shall be included in the plans as follows:

The Contractor shall be required to include with the Falsework Plans, design calculations and details for limiting the outside edge of the deck overhang from deflecting vertically more than 0.25" during the deck placement operations. Acceptable methods of limiting the lateral torsion of exterior

girders include needle beam supports for deck cantilevers, and top flange tie-bars combined with bottom flange struts. Other proposed methods may be submitted for consideration with the falsework plans along with corresponding comprehensive calculations and details. Any tie-bars, connections, hardware or other items associated with the torsion limiting devices that are permanently cast into the deck slab shall be stainless steel or made of an approved corrosion resistant material. No welding of any kind will be allowed on steel bridge girders for attachment of torsion limiting devices. All costs associated with furnishing and installing exterior girder torsion limiting devices shall be included with the deck falsework and are incidental to the item Class A45 Concrete, Bridge Deck.

All submitted contractor falsework plans that utilize exterior girder overhang brackets supporting the bridge deck cantilevers and finish machine screed rails (w/o needle beams) shall be analyzed for exterior girder top flange lateral deflection due to torsion. This analysis should be conducted as part of the normal bridge deck falsework check done in the OBD.

13. Camber is typically cut into the webs of plate girders for dead load deflection and grade. When the camber cut in a girder piece is less than 1/4", camber is not cut in the webs and the haunch is used to "take-up" the dead load deflection of the beam and correct for grade. A minimum haunch of 3/4" is maintained at the abutments and piers.
14. For painted steel girders, no paint is applied to the top of the top flange. When painted steel girders are used with integral abutments, the paint is extended 2" into the abutment, and the remainder of the girder embedded into the abutment is left unpainted.
15. Maximum girder piece length is 145'-0" and maximum girder piece weight is 45 tons.

4.2.6 Substructures

4.2.6.1 General

The bridge substructure is defined as the portion of the bridge below the top of the bearing seat, or, in the case of integral abutment or rigid frame structures, the portion of the bridge that is below the elements that directly support the driving surface (e.g. the portion of the bridge below the slab for a concrete slab bridge).

4.2.6.1.1 Foundations

The foundation type (spread footing, drilled shaft, pile footing, steel pipe pile, etc.) is chosen based on the GEA Report of Foundation Investigation along with due consideration

of structure type, site conditions (frost, scour, debris or ice conditions, crash wall requirements, etc.), uniformity between substructure units, economics, and engineering judgment.

4.2.6.1.2 Frost

The bottoms of all major structure footings are placed below the prevailing depth of frost, which unless otherwise specified in the Report of Foundation Investigation is taken as a minimum of 6 ft.

Integral (stub) abutments are placed 1 ft. below the berm top elevation and backfilled with free draining material to keep frost heaving to a minimum.

4.2.6.1.3 Scour

Scour, as discussed below, is the total scour occurring at a bridge site. at a stream, or river crossing and includes long-term profile changes, contraction scour and local scour (i.e. pier or abutment scour).

Preferred practice is to place the tops of all major structure footings at intermediate supports below the total scour elevation calculated at the 100 year recurrence interval. In cases of extreme total scour depth, the intermediate footing elevations may be raised to a more reasonable depth provided the supporting piling are designed for an unsupported condition. Piling will be designed and proportioned for all applicable load cases, down to the 100 year recurrence total scour elevation.

At end supports abutment scour is mitigated by appropriate countermeasures up to the 100 year recurrence event. For design and proportioning of countermeasure, please see the SDDOT Drainage Manual.

In addition to the design requirements above, all foundations are also investigated for stability to ensure that they do not fail due to the maximum total scour resulting from the super flood (500 year recurrence interval flood or an event that produces the maximum scour up to the 500 year recurrence). Please note at this stability check the structure should be checked for all applicable load cases.

4.2.6.1.4 Piling

When pile founded substructure units are used, the following office practices are employed:

1. Piling type and capacity is based on the Report of Foundation Investigation with due consideration of economics and structure type. To alleviate potential steel H-Pile supply issues, foundations supported on H-Piling shall use HP10x42, HP12x53 or HP14x73 piling unless otherwise approved by the SDDOT Bridge Design Engineer or specifically recommended by the GEA.

2. The use of consistent pile sizes throughout a structure is encouraged.
3. Plan quantities for HP bearing pile shall be calculated based on the cutoff elevation and the tip elevation as shown on the Report of Foundation Investigation and shall be shown in 5 ft. increments, rounded up to the nearest 5 ft. Plan quantities for HP test pile shall be 5 ft. longer than the bearing pile length listed.

4. Pile embedment is as follows:

Timber piles in footings = 12 in.

Timber piles in stub abutments = 2 in. with 3 no. 4 bars 4 ft. in length driven 2 ft. into the timber pile.

Steel H pile in footings: Footings <3'-0" thick, use 1'-6"

Footings \geq 3'-0" thick, use 1'-9"

Steel H pile in abutments = 2'-0"

Steel pipe pile in abutments and as pile bents = 2 in. with reinforcing steel in the top 3 ft. extending into the structure.

5. Individual piling in a footing pile group are not designed to resist moment, only axial load. If horizontal restraint is necessary, an appropriate number of piling are battered (2 in 12). Moment transfer through the footing from the column or shaft is resisted by the axial load capacity of the piling depending on their respective distances from the neutral axis of the pile group. Normally, uplift is not permitted in pile footing design. When uplift is used, contact the GEA for allowable pile loading in tension.
6. Pile founded footings are designed for the vertical loads as well as the longitudinal and transverse moments from the various loading combinations and their respective group reduction factors. The pile group is designed such that no pile in the pile group exceeds the allowable pile capacity. The pile group reduction factor is applied if deemed applicable by the GEA.
7. Piling subject to moment is considered fixed at a point one third its length below the surface or at a point determined by the GEA. Engineering judgment should be used in cases where the embedment length is excessive.
8. Pipe piles are driven closed end, unless otherwise recommended by the GEA.

4.2.6.1.5 Drilled Shafts

When drilled shafts are used, the following office practices are employed:

April 2026

1. Drilled shafts subject to moment are considered fixed at a point one third its length below the ground surface/flowline or at a point determined by the GEA. Engineering judgment should be used in cases where the embedment length is excessive.
2. Drilled shafts are designed for skin friction for the portion of the shaft below the friction elevation using the values as recommended in the Report of Foundation Investigation. End bearing is conservatively neglected in determining required shaft length.
3. The minimum shaft diameter is 36 inches. A minimum clear cover of 3 inches is maintained from the sides of the shaft to the spiral steel. No. 4 spiral steel is used for reinforcing steel cages with a diameter of 48 in. or less, and no. 5 spiral steel is used for cages with diameters greater than 48". The pitch of the spiral steel is held at 6 in. (same as normal tied column steel). Longitudinal reinforcing steel is spaced such that a minimum clear spacing between bars of 4 inches is maintained, including lap locations.

4.2.6.1.6 Spread Footings

When spread footings are used, the following office practices are employed:

1. The bottom of the spread footings are placed at the elevation listed in the Report of Foundation Investigation, at the appropriate scour elevation, or below the frost line, whichever is greater. If sound rock is encountered at or above the frost line, the bottom of the footing may be placed at the rock level and not down to the frost depth.
2. When possible, the footings are designed so that the entire footing will be effective in bearing under all load cases. However, when this results in excessive footing dimension, uplift or reduced effective footing dimensions are utilized to keep footing sizes reasonable.
3. When required by the Report of Foundation Investigation or by loading conditions, the footing is doweled into the supporting rock. Standard practice is to use no. 11 dowels embedded 30 in. into bedrock and spaced no greater than 6 ft. nor less than 18 in. Minimum distance to the edge of the footing is 12 in.

4.2.6.2 Abutments

For abutment design, the current *AASHTO LRFD Bridge Design Specifications* shall be used with the following office practices:

April 2026

4.2.6.2.1 Integral (Stub) Abutments:

1. For girder depth < 45 " Abutment wingwalls will be straight with maximum length of 7'-0".
2. For girder depth > 45 " wingwalls will be swept back with maximum length of 16'.
3. On continuous concrete bridges the wingwalls will be straight.
4. A single line of steel piling shall be used with the piling oriented such that the web of the pile is parallel to the centerline of the abutment. For steel girder structures the web of the pile will be perpendicular to the girder centerline.
5. Prebore depth for abutment piling will be provided in the GEA Foundation Report or will be minimum of 10 ft. or to natural ground line, whichever is greater.
6. For continuous concrete slab bridges and prestressed girder bridges, maximum pile spacing is 10 ft. For steel girder bridges, use one pile at each girder location. Long spans may require additional piling between girders.
7. For holes thru the web to accommodate reinforcing in steel girders on integral abutments, OBD standard practice is to make the holes the same diameter and meet the size requirement for the larger bar. On girders for skewed bridges check the hole size to ensure bar can be placed.
8. OBD Standard practice is using #6 bar minimum in the front face of integral abutments for steel girders and in the front face of the pile cap for prestressed girder.
9. Minimum abutment thickness is 2 ft. Increase abutment thickness as required for skewed girder structures to keep girder ends and/or extended and bent strands (prestressed girder bridges) within the reinforcement cage. Steel flanges may be "clipped" to keep within the reinforcing cage. The standard extended and bent strand detail may be modified slightly as required to keep bent strands within the limits of the abutment reinforcing steel cage for more severe skews. In addition, backwall thickness may be increased to accommodate larger piles as necessary to keep the piling within the limits of the reinforcing steel cage. Due consideration should be given to pile driving tolerances when determining backwall thickness.
10. Wingwall thickness on continuous concrete bridges is reduced to 1 ft. at the outside edge of the barrier. Wingwall thickness on girder bridges is kept the same as the backwall thickness of the abutment on straight wingwalls and on "swept back wingwalls" the wingwall thickness is reduced to 1'- 4" to match the barrier thickness atop the wingwall or 1'-0" when swept back wingwalls are outside the

barrier.

11. For prestressed girder bridges all efforts to minimize the height of the abutment from the bottom of the pile cap to the deck surface will be made. Standard practice is to start with a 3' – 0" tall 2' – 0" wide pile cap and 1.5" grout pad projection at the low girder. When roadway geometry causes grout pad projection to exceed 6" from the top of the pile cap either the grout pad will be reinforced, or the pile cap will be stepped at the discretion of the engineer. At no time will the pile cap portion of the abutment exceed 3' – 6" due to stepping for roadway crown. When roadway dictates the bottom of the cap will be stepped to stay within these limitations.
12. The backwalls of integral abutments for prestressed girder bridges are covered with a waterproofing membrane from above the deck-backwall construction joint to below the backwall-pile cap construction joint to prevent moisture from leaching through the backwalls at the girder locations. See Figure 4.2.6-1.
13. A 9" x 6" paving notch is provided in the back face of all integral abutments to accommodate an approach slab.
14. On all abutments the z bar in the paving notch at the back of the abutment to tie the approach slab to the superstructure will be detailed full length and shown in the reinforcing schedule full length. By plan note the contractor may substitute 2 short bars and a mechanical splice.

Typical integral abutment cross sections are shown in Figure 4.2.6-1 thru Figure 4.2.6-3.

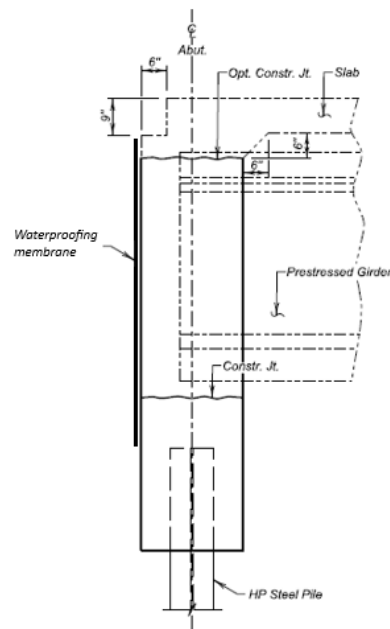

Figure 4.2.6 - 1 Integral Abutment Prestressed Girder Bridge

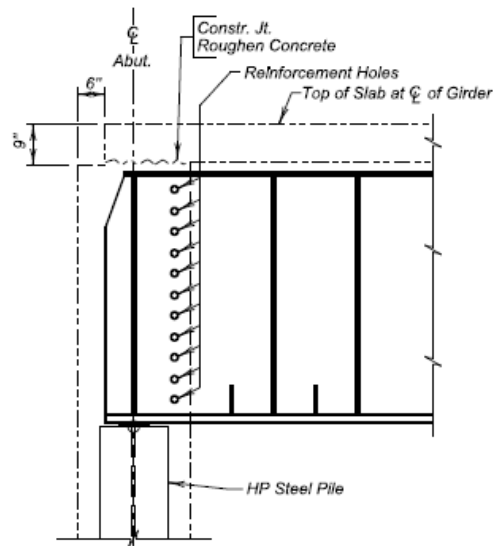

Figure 4.2.6 - 2 Integral Abutment Steel Girder Bridge

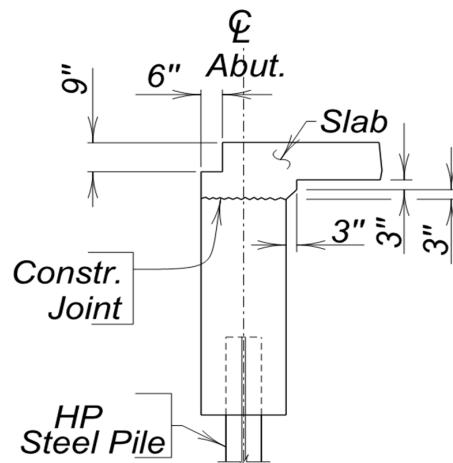

Figure 4.2.6 - 3 Integral Abutment Continuous Concrete Bridge

4.2.6.2.2 Sill Type Expansion Abutments:

1. Wingwalls will generally be straight if the length becomes excessive than swept back wingwalls can be designed but will need approval from the Bridge Design Engineer.
2. Use a minimum of 2 piling at each bearing location. The piling are placed with the strong axis parallel the abutment centerline. The front piling is normally battered to help in resisting the lateral loads from the backfill.
3. Minimum sill thickness is 2.5 ft. Minimum backwall thickness is 1 ft.

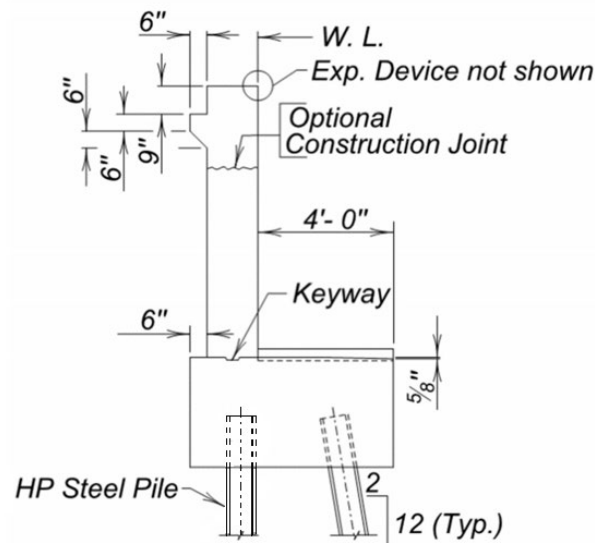

Figure 4.2.6 - 4 Sill Type Abutment for Girder Bridges

4.2.6.2.3 Vertical Abutments:

1. Vertical abutments are normally founded on rock. Spread footings are utilized for structures without moment resisting joints at the top of the abutment and strip footings with a hinged joint at the top of the footing are utilized for frame type structures with moment resisting joints at the superstructure/abutment joint. When rock is not available at a reasonable depth, vertical abutments may be founded on piles.
2. Abutment wingwalls are normally cantilevered off of the backwall unless the wingwall length or other geometry is such that the reinforcement required between the wingwall and the backwall becomes excessive or in the case of rigid frame structures. In these cases, the wingwalls are constructed as standalone retaining wingwalls.
3. 3 in. weep holes are provided at the ordinary high water elevation to drain the backfill and keep hydraulic pressures minimized. In addition, 2 in. of polystyrene insulation is used below the weep holes on the back side of the abutment.
4. Boundary conditions and restraint are very important when designing vertical abutments. It is critical that the engineer accurately predict the behavior of the structure in their structural model. Wingwall attachments/configuration, abutment configurations, and joint details have a considerable impact on the structural response of the structure.

4.2.6.3 Bents and Piers

For bent and/or pier design, the current *AASHTO LRFD Bridge Design Specifications* shall be used with the following office practices:

4.2.6.3.1 Frame Bents

1. Frame bents are generally designed and constructed integral with continuous concrete slab bridges. Where excessive moments result from the effects of temperature and shrinkage, pinned connections at the top of the columns or non-integral bents with expansion bearings may be used. The designer is cautioned to consider overall structure stability when using pinned columns.
2. Column spacing is chosen to balance the negative moments in the bent cap over the exterior column with the positive moment at the midspan between columns.
3. Minimum column diameter is 2'-3" except when drilled shaft foundations are used, in which case the minimum diameter is 3'-0". The designer is encouraged to use column sizes for which standard column forms are available.
4. Bent caps for girder bridges are normally 6 in. wider than the columns and square in cross section. For bents constructed integral with the superstructure in continuous concrete slab bridges, the bent cap is normally 4 in wider than the columns and is designed as a T-beam with the portion of the slab above the bent cap utilized for section design. The depth of the cap below the slab is kept as shown in Figure 4.1.1-2 Figure 4.1.1-3.
5. Minimum footing thickness for spread footings or pile caps is equal to the column diameter.
6. When web walls are required by hydraulics for debris or ice concerns, bents are designed independently of the web. Standard web wall is a one foot thick web extending from the bottom of the bent cap to one foot below the flowline elevation shown on the *Hydraulics Data Sheet*.
7. Columns are normally designed as fixed at the bottom. When drilled shafts are used the column is assumed to be fixed at the friction elevation established by GEA and listed in the Report of Foundations Recommendations. At the top in the transverse direction, the columns are assumed to be fixed against rotation and free to translate. In the longitudinal direction the top of the column is assumed to be free to both translate and rotate.
8. Normal practice is to use tied columns with a 6 in. pitch spiral for lateral reinforcement. Spacer bars are required for spiral reinforcement, the number of spacer bars in each column should be according to section 5.10 Spiral

Reinforcement and Spacers in the CRSI manual. Update notes in the reinforcing schedule include weight in the reinforcing quantity. Weight is figured at $\frac{3}{4}$ pound per foot. If the foundation is drilled shafts the spacer should extend the full length of the shaft.

MINIMUM NUMBER OF SPACERS PER SPIRAL

Spiral Bar Diameter	Spiral Core Diameter, in.	Minimum Number of Spacers
$\frac{3}{8}$ in. or #3	Less than 20	2
	20 to 30	3
$\frac{1}{2}$ in. or #4	More than 30	4
	24 or less	3
$\frac{5}{8}$ in. or #5	More than 24	4

Figure 4.2.6 - 5 Spacers Required for Column Spiral Reinforcing

4.2.6.3.2 Pile Bents

1. The slenderness ratio is not allowed to exceed 100.
2. 16 inch $\frac{1}{2}$ inch wall thickness pipe piles are driven closed end and filled with unreinforced concrete (reinforcement is placed in the top 3 ft. to make the connection to the pile cap). The connection of the top of the pile to the deck, in the case of a continuous concrete slab bridge with driven pipe pile bents, is checked for punching shear to ensure that the pile will not punch through the deck under design loading. The pipe piles are then checked for bearing, axial load and moment analyzing the concrete filled pipe as a reinforced concrete column pinned at the top and fixed at the bottom. Concrete used to fill pipe pile will be Class A45 concrete.
3. The steel pipe, minus $\frac{1}{16}$ in. for corrosion, is considered the reinforcing steel for the center concrete portion for analysis.
4. A 3 in. out of position tolerance for the top of the pile is handled by designing the column for 3 in. eccentricity on the axial load applied.

4.2.6.3.3 Pier Walls (Including Pier Walls with Cantilevers)

1. Minimum wall thickness is taken as 16 in. The slenderness ratio in the longitudinal direction is not allowed to exceed 100.

2. Cantilever lengths for hammerhead pier walls are limited to $1/4$ of the width of the wall or 10 ft., whichever is greater. Depth of the cantilever at the face of the wall is normally taken as $1/2$ of the cantilever length.
3. For girder type superstructures, a square cap is placed on top of the pier wall, sized to accommodate grout pads and bearings. Pier walls supporting slab type superstructures are either framed into the slab or connected using a pinned connection, depending on structure specifics.
4. Minimum footing thickness supporting pier walls is 2 ft.
5. Lateral reinforcement for pier walls shall consist of ties spaced not greater than 12" in the vertical direction and per AASHTO code in the horizontal direction.

4.2.6.3.4 Single Column Hammerhead Piers

1. Single column hammerhead piers are typically used in streambeds that have a history and tendency to meander. Single columns are efficient at many different stream attack angles.
2. Most single column hammerhead piers are founded on large, drilled shafts (6' – 0" to 10' – 0" diameters). The point of fixity will be located at the GEA recommended skin friction elevation provided in the Report of Foundation Recommendations. When pile caps or spread footings are utilized, the point of fixity will be taken at the bottom of the column.
3. Caps for this substructure type will taper in both depth and width and will be proportioned to resist the force effects applied from the superstructure and stream and ice forces.
4. Columns will utilize the same reinforcing cage as the drilled shaft. Reduction in column diameter with respect to the drilled shaft is allowed but is discouraged and should only be done with permission from the Bridge Design Engineer.
5. On severe skews and grades care shall be taken so that clearances between the girders and cap are maintained. When they cannot, the top of cap elevation may need to be lowered or stepped to maintain clearances.

4.2.7 Miscellaneous Structures

4.2.7.1 Signal Pole and Luminaire Footings

When designing signal and luminaire pole footings, the *AASHTO LRFD Specifications for Structural Supports for Highway Signs, Luminaires and Traffic Signals* is used with the following criteria:

1. The 700 year mean recurrence interval is used for all luminaire and traffic signal footings except traffic signal pedestal poles where a 10 year mean recurrence interval is used.
2. In determining the required footing depth, the top 2 ft. of soil is assumed to be ineffective. The minimum effective depth used is 4 ft. resulting in a total minimum depth of 6 ft. for all footings. Footing depth should be increased as needed in 1 ft. increments.
3. At the request of a city or municipality accommodation for attachments (banners, flowerpots, etc.) may be made. The cost of any attachments will be the responsibility of the city or municipality. The size and weight of the attachments must be known, and both the footing and light pole structure must be designed to accommodate the additional loads. If the additional wind load for holiday decorations increases the depth of the footing by more than 1 foot, consider reducing the design surface area with approval from the Bridge Design Engineer.
4. For the range of soil strengths normally encountered and where no constraints of footing depth exist (i.e. bedrock etc.), it has been our experience that increasing the depth of footing is more efficient than increasing the diameter of footing.

Other standard practices are outlined below:

1. Structural support members other than footings for signals and luminaires are designed by fabricators to the AASHTO Specifications and our requirements. All footings for signals and luminaires on state projects are designed in the Office of Bridge Design.
2. Traffic signal and luminaire footings are designed for wind and dead loads based on an assumed multi-sided tubular pole geometrically similar to that of Millerbernd. When investigating the ice load case, the same pole configuration as for wind and dead load is used.
3. A cylindrical reinforced concrete footing is used in all but special cases. A spread footing may be used where the elevation of bedrock prevents the use of the standard footing. Footings for high tower lighting may be cylindrical, spread, or founded on

piling, as required by design loads, site conditions and economics.

4. Cylindrical footing size is determined using the factored geotechnical resistance provided by the GEA. The calculated soil bearing pressure above the footing's neutral axis is limited to the allowable upper bearing pressure as determined by the GEA based on soil tests. Maximum deflection of the footing (at the ground surface) is 1/2 in.
5. When the *Report of Foundation Investigation* indicates that water may be encountered during footing excavation, a plan note regarding high water table with the date of the investigation, corresponding water elevation, and possible casing recommendations is added to the plans to alert the Contractor.
6. The minimum footing diameter for pedestal mounted traffic signals and luminaires is 2'-0" and for traffic signal poles is 3'-0". Footing diameter is normally increased in increments of 6 in. as required.
7. Cylindrical type concrete footings are reinforced similar to columns. A reinforcing cage consisting of longitudinal bars enclosed within a spiral is used. The total area of the longitudinal reinforcement is equal to or greater than 1 % of the gross cross sectional area of the concrete section. A no. 3 spiral bar with 12 in. pitch is normally used. Hoops of the same size and spacing may be used at the Contractor's option. Minimum clear cover is set at 2 in. on the sides of the footing and 3 in. at the top and bottom of the footing.

4.2.7.2 Sign Supports

The SDDOT utilizes various types of post material and shapes. Steel W-shapes and S-shapes are the most common posts used on the larger informational or logo signs that require two or more supports. Flanged (maximum depth of 5 in.) and pipe (maximum diameter of 4 in.) steel posts, wood posts, U-channel posts and perforated square posts are most commonly used for signs requiring one support.

All signs on high speed highways located within the clear zone widths determined by the criteria given in the *SDDOT Road Design Manual* shall be placed on breakaway supports. Signs located outside suggested clear zone may be put on fixed supports, unless there is a history or other high probability of being struck by errant vehicles.

When designing sign supports, the current *AASHTO LRFD Specifications for Structural Supports for Highway Signs, Luminaires and Traffic Signals* shall be used with the following office practices employed:

1. Use The 700 year mean recurrence interval
2. Anchor bolts shall conform to ASTM F1554, Grade C having a minimum yield stress of 36 ksi.
3. Concrete in footings shall be Class “M6” with $f'c = 4000$ psi.
4. Structural steel shall conform to ASTM Specifications A36.

Standard detail and calculation sheets are available from the OBD for fixed and breakaway sign supports.

4.2.7.3 Structural Plate High Profile Arch Structures

Long span structural plate high profile arches may be used at railroad overheads when economical or when safety concerns warrant. Structural plate arches are generally not used for hydraulic crossings due to scour potential.

Structural plate arches are designed by the fabricator to the appropriate AASHTO Specifications and calculations are provided for review. Footings for the structural plate arches are designed in-house with loads calculated based on the structural plate arch to be supplied.

Recommendations for allowable footing bearing loads as well as for special backfill requirements, including material specifications and backfill geometry, as applicable, are provided as recommended by the GEA.

4.2.7.4 Retaining Walls

Several types of retaining walls are used including cast-in-place concrete gravity walls, gabion retaining walls, gravity bin type walls, soldier pile walls, cantilever sheet pile walls, large block gravity walls and mechanically stabilized earth (MSE) walls including T walls for some railroad applications. Drainage tubing will be required at the base of the retained material and placement, elevation, and outlet location shall be provided in the plans.

Final wall type selection should be based on economics, aesthetics and applicable site specific conditions.

When designing retaining walls, the current *AASHTO LRFD Bridge Design Specifications* shall be used with the following exceptions:

1. Lateral earth pressure is calculated using the Rankine Method.

2. A value of 120 lb./ft.³ is used for the 2 ft. surcharge (when applicable).

Mechanically stabilized earth (MSE) and gravity block walls are designed by the contractor/supplier. A list of approved companies and their systems is maintained by the Office of Materials and Surfacing. Plan preparation consists of a general drawing sheet with a layout showing the wall location, drain with outlets, a typical section through the wall, quantities for bidding, and a subsurface investigation sheet (provided by the GEA). Appropriate plan notes are also provided to cover required submittals by the supplier and Contractor as well as any site specific requirements.

4.2.7.5 Stream Stabilization

4.2.7.5.1 Riprap

Riprap type erosion protection is used when specified by the Hydraulics Section. The limits described in the *Hydraulic Data Sheet* are followed for plan dimensions and quantities.

4.2.7.5.2 Gabions and/or Rock and Wire Baskets

Rock and wire basket type erosion protection is used when specified by the Hydraulics Section. The limits described in the *Hydraulic Data Sheet* are followed for minimum plan dimensions. Normally, plan dimensions and quantities are calculated using standard commercially available gabion sizes and allowing, by plan note, the substitution of rock and wire baskets to the minimum dimensions shown. Gabion quantities are calculated using the values listed in the South Dakota Department of Transportation Standard Plate No. 720.01. No additional payment is allowed for the substitution of rock and wire baskets.

4.2.7.5.3 Miscellaneous Stream Stabilization Structures

Other stream stabilization and protection structures, including wingdams, sheet pile deflectors, and various energy dissipaters are designed to the dimensions included with the *Hydraulics Data Sheet*. The Hydraulics Section should be contacted to verify final plans and for any questions that may arise.