

Revised October 2021

# Earthwork



CHAPTER 1	
INTRODUCTION - - - - -	3
THE ROLE OF AN INSPECTOR - - - - -	3
COMMUNICATIONS AND ATTITUDE - - - - -	3
QUALIFICATIONS OF THE INSPECTOR - - - - -	4
SAMPLING AND TESTING - - - - -	5
RECORDS - - - - -	5
INSPECTOR EQUIPMENT AND MATERIALS - - - - -	5
SUMMARY - - - - -	6
CHAPTER 2	
PREPARATION FOR CONSTRUCTION - - - - -	7
PLAN REVIEW - - - - -	7
PROPOSAL REVIEW - - - - -	8
PRELIMINARY PROJECT INSPECTION - - - - -	8
MATERIALS AND CERTIFICATION REVIEW - - - - -	8
PRE-CONSTRUCTION MEETING - - - - -	-10
CHAPTER 3	
CONSTRUCTION DOCUMENTATION- - - - -	12
FIELD DIARY - - - - -	-12
EXTRA WORK AUTHORIZATION - - - - -	-14
FORCE ACCOUNT - - - - -	-15
FORCE ACCOUNT SUMMARY - - - - -	19
CHAPTER 4	
HIGHWAY LAYOUT - - - - -	-20
ROADWAY ELEMENTS - - - - -	-20
TYPICAL GRADING SECTION - - - - -	-22
CHAPTER 5	
CONSTRUCTION EQUIPMENT - - - - -	-24
SCRAPER - - - - -	-24
TRACK TYPE TRACTOR (BULLDOZER) - - - - -	25
MOTOR GRADER - - - - -	-26
FRONT END LOADER - - - - -	-27
BACKHOE (EXCAVATOR) - - - - -	-27
WATER TRUCK - - - - -	-28
DISK - - - - -	-28
CHAPTER 6	
PRELIMINARY WORK - - - - -	-29
PIPE AND OTHER SALVAGEABLE MATERIALS - - - - -	29
ASPHALT SALVAGE - - - - -	-30
NON-SALVAGEABLE MATERIAL - - - - -	-30
STEEL BRIDGES AND SIMILAR STRUCTURES - - - - -	-31

CHAPTER 7	
EXCAVATION AND EMBANKMENT CONSTRUCTION	-32
TOPSOIL	-32
CUT SECTIONS	-33
UNCLASSIFIED EXCAVATION	-34
ROCK EXCAVATION	-36
MUCK EXCAVATION	-39
UNDERCUTTING	-39
BACKFILLING	41
ADDITIONAL MATERIAL	-42
ADDITIONAL EXCAVATION	42
TEMPORARY EASEMENT	-42
BORROW MATERIAL	-43
OPTION BORROW	-43
DISPOSAL OF SURPLUS EXCAVATION AND WASTE	-49
EMBANKMENT	-50
TYPES AND PLACEMENT OF EMBANKMENT MATERIAL	-51
EARTHWORK BALANCE	52
HAUL	53
COMPACTION OF EMBANKMENT	54
SURCHARGE	-56
DENSITY	-56
SPECIFIED DENSITY	-56
ORDINARY COMPACTION	-56
MOISTURE CONTENT	57
PREWATERING (PRE-IRRIGATION)	-59
COMPACTION DEFICIENCIES	60
CHAPTER 8	
CONSTRUCTION STAKES	-61
CONTROL POINTS	-61
BENCHMARK	-61
HUB LINE	-62
RIGHT-OF-WAY STAKES	-63
REFERENCE POINTS	-63
OFFSET STAKES	-64
SLOPE STAKES	-65
GRADE AND SLOPE CONTROL	-71
EQUIPMENT	-71
GRADE CONTROL	-75
FILL SECTION	-76
BLUE TOPS	77
CHAPTER 9	
FIELD TESTING	79
MOISTURE TESTS	-79
DENSITY TESTS	82
STANDARD DENSITY SPECIFICATIONS	84

CHAPTER 10	
DRAINAGE - - - - -	88
CHAPTER 11	
FENCING - - - - -	-89
REMOVAL OF EXISTING FENCE - - - - -	89
PLACEMENT OF RIGHT-OF-WAY-FENCE - - - - -	89
CHAPTER 12	
FIELD LABORATORY - - - - -	91
CHAPTER 13	
GLOSSARY OF TERMS - - - - -	-94
CHAPTER 14	
MEASUREMENT CONVERSIONS - - - - -	-98
CHAPTER 15	
ANSWERS TO MANUAL'S PROBLEMS - - - - -	103

All figures cited in this manual are in the envelope at the back of the manual.

Note Throughout this manual, reference is made to provisions of the South Dakota Standard Specifications for Roads and Bridges. For example, (120.3.A.) refers the reader to Section 120.3 paragraph A, Excavation in the specification book.

Additional manuals that the earthwork inspector should be familiar with are:

- Materials Manual
- CMP Manual
- Survey Manual
- Pipe Installation Manual
- Erosion Control Manual

This book should be kept by the Earthwork Inspector as a reference guide during the performance of his duties. If, after participating in the course or during construction, you have ideas or suggestions for improving the course submit them for incorporation in future training courses.

The Department of Transportation is grateful for and wishes to recognize the efforts of its employees who have made significant contributions to the improvement of this training manual. Those employees include:

Matt Stone, Rapid City

Harlen Brown, Winner Area (Retired)

## INTRODUCTION

### THE ROLE OF AN INSPECTOR

---

The construction of a sound earth roadbed is an essential part of highway construction. It provides the foundation for the base and surface courses.

The Earthwork Inspector is given the responsibility of assuring that a sound earthwork foundation is constructed. Training Activity has provided this course to aid and assist the Earthwork Inspector in this task. This course contains important instructional material, procedures and policies that have been developed to maintain uniformity among Earthwork Inspectors.

Earthwork involves all of the various construction activities that are needed to prepare a roadbed to its final sub grade elevation. A typical earthwork project will include:

- Surveying
- Erosion Control
- Pipe Installation
- Clearing and Grubbing
- Excavation
- Embankment Placement
- Surfacing
- Fencing

This course will cover what you need to know, do and look for during the inspection of excavation and embankment placement.

### COMMUNICATIONS AND ATTITUDE

---

Communication is one of the most important aspects of an inspector's job. Communication is essential to ensure that the project is properly managed. The inspector helps the contractor anticipate problems and helps find ways to resolve them. The inspector is friendly but firm and impartial in making decisions when dealing with the contractor and his/her personnel.

One of the most important steps in establishing communications is the preconstruction meeting. These meetings are held before the beginning of any major

construction project. At the meeting, the inspector becomes acquainted with the contractor's key personnel. Attendees will discuss the plans and specifications for the project, traffic control techniques, and define lines of authority.

The inspector is proactive by understanding the project from the contractor's point of view. The inspector does not permit reduced quality in order to increase the contractor's productivity.

An inspector influences the construction process to obtain the best possible results. He/she cannot watch any particular situation passively. If an inspector has a suggestion for changing a procedure to improve the quality and efficiency of the work, he/she does not hesitate. This benefits both the Department and the Contractor.

The inspector's attitude is especially important. Offer assistance while being careful not to supervise construction. Inspectors must avoid giving the impression that they control the work. An inspector should never issue a direct order to the contractor's workers. The inspector must never assume supervision of the work. The task is to judge the quality of work that is performed by methods that meet specifications. Failure to do this can cause legal problems later.

## **QUALIFICATIONS OF THE INSPECTOR**

---

- Be honest and conduct him/herself in a fair straightforward manner.
- When under stress, the inspector must still be able to maintain personal composure and make good decisions.
- Be frank and sincere in relationships with people, and be a skilled diplomat able to handle tough situations without arousing hostility.
- Be observant and be capable of keeping neat, concise accurate records.

Technical study and/or construction experience is necessary to perform well as in inspector. The inspector must:

- Be able to perform accurate mathematical calculations.
- Know how to read and understand plans, specifications, and other contract documents.
- Understand the basic engineering principles of roadway design.
- Be familiar with the characteristics of construction materials.
- Know the principles of material testing as well as how to interpret the test results.

If all the qualifications of an inspector could be reduced to four, they would be:

- Knowledge
- Common Sense
- Observational Skills
- Courtesy.

Knowledge - The more knowledge the inspector has, the better prepared he/she is to perform his/her duties. The inspector should be familiar with the technical aspects of construction, equipment operation and policy. The inspector should make frequent use of this and other materials to ensure accurate tests and checks.

Common Sense - While common sense is no substitute for knowledge, it is the means by which an inspector can interpret specifications to enforce their intent. Common sense grows out of knowledge and cannot be learned from a book.

Observational Skills - It is important for an inspector to look carefully at everything going on around the site. "Seeing," means thinking carefully about what the eyes observe. Then corrections, documentation, and testing are more accurate.

Courtesy - A major part of the inspector's job is to inform the contractor when conditions are unsatisfactory or when the specifications are not being met. The contractor expects the inspector to provide suggestions to improve operations. Yet the inspector's manner of presenting the comments can cause a poor relationship. Experience shows that it is not what is said as much as the way it is said that is important. Gruff, bossy, and sarcastic comments are unacceptable from any inspector, even if given in answer to a contractor's aggravating remarks. Be friendly, courteous and positive.

## **SAMPLING AND TESTING**

---

Sampling and testing are methods of evaluating the quality of the work. The inspector must know where and how to correctly sample. The inspector must make sure that every sample is identified with the proper information. The inspector must be equally as confident and knowledgeable about prescribed testing procedures and documentation of results. Follow the Materials Manual for guidance.

## **RECORDS**

---

One of the most important functions of the inspector is to keep accurate records and document thoroughly. Records and reports are necessary to determine that contract requirements have been met so that payments can be made to the contractor. Records and reports should be kept current and submitted on schedule. They should be neat, complete and legible.

- The inspector is given standard forms for routine reporting.
- The form may require daily, weekly or monthly entries.
- In addition to the standard forms, the inspector should keep a written or electronic diary of activities.

The importance of entries listed in the inspection's diary cannot be over emphasized. The information is a reference that can be used to perform similar future work or in case of legal action. More importantly, it can give clues for investigators in case the job fails.

- Records and reports are used to determine quantities of materials for payment.
- They ensure that the contractor is paid fairly.
- The basis for calculation of material quantities, such as field measurements, should be indicated on the inspector's report.
- The quantity records must be complete and accurate.
- The quantities of materials wasted or rejected should be identified so those totals can be checked by audit.

## **INSPECTOR EQUIPMENT AND MATERIALS**

---

The inspector, in addition to what is available from the field lab, needs these few items:

- 1 Specifications Book referenced in the project plans



- 2 Set of plans for the project
- 3 A Materials Manual
- 4 Lined tablet and pencils
- 5 Project diary or electronic data recorder
- 6 Hand held calculator
- 7 Metric and English measuring device
- 8 DOT forms
- 9 Laptop with CMP & MS&T installed

## **SUMMARY**

---

The role of the inspector is to see that the plans and specifications are followed. This requires that the inspector be honest, sincere, knowledgeable and courteous. It also requires that he/she develop the skill of observation and use common sense. In addition, the inspector must be able to keep neat, concise, accurate work records.

The inspector's responsibility is to identify to the contractor any situation in which plans and specifications are not being followed. The inspector does not have the authority to reject or suspend payment for any work that does not meet job requirements. Nor does the inspector have the authority to supervise the contractor's workers or to give orders.

To maintain good working conditions, the inspector must have relationship with the contractor in which both parties understand and respect each other's viewpoints.

To do a professional job, the inspector must want to do a good job, know how to do it, and then go about it in a professional manner.

# PREPARATION FOR CONSTRUCTION

Before your actual inspection duties commence, a number of preliminary activities are necessary. For purposes of this course, we will assume survey work has been completed.

## PLAN REVIEW

---

Prior to construction, a complete review of the plans and specifications should be conducted so you are familiar with the requirements of the project

As per Section 5.4 in the Standard Specifications for Roads and Bridges, the sequence of priority concerning Specifications is:

- Special Provisions
- Plans Notes
- Supplemental Specifications
- Standard Specifications

Special Provisions govern over the Plan Notes, Supplemental Specifications and Standard Specifications.

Plan Notes govern over Supplemental Specifications and Standard Specifications.

Supplemental Specifications govern over the Standard Specifications.

The figures at the back of the book are example sheets from different plans for you to refer to throughout the course.

- Figure 1 - Typical Grading Section
- Figure 2 - Plan/Profile Sheet
- Figure 3 - Cross Section
- Figure 4 - Cross Section (Muck Excavation)
- Figure 5 – Cross Section (Surcharge)
- Figure 6 - Pit Information Sheet
- Figure 7 - Waste Embankment Deposit Site

## **PROPOSAL REVIEW**

---

The Proposal for a set of plans should be reviewed for the following items:

- Special Provisions
- Supplemental Specifications
- Agreement to Sell Material
- Haul Road Agreement
- Utility Adjustment Plans

In addition to the plans and proposal, the following items should be reviewed:

- Figure 8 - Right of Way Agreements/Temporary Easement Agreements

## **PRELIMINARY PROJECT INSPECTION**

---

Tour the project to become familiar with the area and how the location of the roadway, important survey points and other physical data relate to the project plans. Look for possible problems and locations that may require special observation and/or handling. The following are some examples of specific potential problem areas:

- Wet or boggy areas
- Bentonite or other soil types
- Special rock conditions

During your tour become familiar with soil surveys from the roadway, borrow areas and physical locations. The Soils Profile will show the location of each roadway and borrow test hole and their respective test results from laboratory analysis. The Soils Profile review will also familiarize you with general soil types, depths and moisture conditions of materials that will be encountered during excavation work.

## **MATERIALS AND CERTIFICATION REVIEW**

---

Review Materials and Certification required for the project. This information is available on the DOT-14. An example of a DOT-14 is shown on the following page.

Review the Materials Manual for other requirements and test procedures.

**Figure 2.1** Example DOT-14

**Summary of Requirements for Tests and Certs**

**DOT - 14**

**Contract:** 3609 **Date Let:** 09/21/2011  
**PCN:** 6954 (Main) Related PCN 03CY  
**Project(s):** P 0073(44)37 (Main) Related Projects P 0073(64)37  
**County:** Bennett, Jackson  
**Location:** Fm the Bennett/Jackson Co Line to N of the N Jct of SD44  
**Type of Work:** Grading, Structures and Blotter Surfacing  
**Contractor:** Loiseau Construction, Inc **Length:** 15.428 miles  
**Engineer:** Richard Frazier **Area:** Winner Area

Material	Quantity	Unit	Reqd	Made	Requirement
120 Unclassified Excavation	1,740,841.0	CuYd			
			*	10	Cross Pipe Pre-Install Dens. for Acceptance - One below each mainline cross pipe prior to installation
	1740841/200000 = 9		9	4	In-Place Emb Den or S. Analy for Independent Assurance - Density or soil classification. Not required if less than 10,000 cu. yds..
			*	62 U	In-Place Emb Den or S. Analy for Acceptance - Density or soil classification.
			*	48	InPlace Pipe/Box Den or SAnaly for Acceptance - Density or soil classification.
			*	3	InPlace Pipe/Box Den or SAnaly for Independent Assurance - Density or soil classification.
			*	178 U	Moisture Content - Embankment for Acceptance - One per 2 hours
			*	1	Moisture Content-Pipe/Box Emb for Acceptance - One per 2 hours
			*	2	Sieve Analysis (Four Point) for Information Only - One per source, combination or type (Not req'd. if 5,000 cu. yds. or less)
			*	2	Standard Density (4 Point) for Acceptance - One per soil type (Not req'd. if 5,000 cu. yds. or less)
120 Pit Run Material (Tier 3)	60.0	TON			
			1	0	Visual Inspection for Acceptance
260 Base Course (Tier 3)	80,020.2	TON			
	80020/50000 = 2		2	1	Central Lab Test for Quality
			1	3	In-Place Density for Acceptance - One per mile per lift
			*	0	In-Place Density for Independent Assurance - One per 4 miles - None req'd if less than 1,000 tons
	80020/3000 = 27		27	14	Sieve Analysis for Acceptance
	80020/15000 = 6		6	2	Sieve Analysis for Independent Assurance - None req'd if less than 1,000 tons
			1	1	Sieve Analysis (Four Point) for Information Only - One per source, combination or type
			1	1	Standard Density (4 Point) for Acceptance - One per source, combination or type

# PRE-CONSTRUCTION MEETING

---

The Pre-Construction meeting is the inception of physical work. Remember to come to this meeting with a positive partnering attitude. This is your opportunity to make a good first impression for the Department and yourself, you may not get a second chance. You begin to use the FOUR QUALIFICATIONS FOR AN INSPECTOR at this meeting.

Get acquainted with the Contractor and his/her foreman, you will be spending a lot of time together. Be aware the foreman's duties are to the Contractor and inspector's duties are to the Department. The inspector is the Department's diplomat, always convey your concerns in a polite and pleasant manner.

A good set of notes of topics and matters discussed at this meeting is strongly suggested. Areas that should be covered are:

- Construction Work Schedule and Sequence of Operations
- Construction Signing and Traffic Control
- Review of Plans
- Review Erosion Control Measures
- Review of Materials
- Special construction methods that may be utilized
- Special equipment that may be utilized
- EEO requirements
- Project safety program
- Utilities

A letter covering all subjects discussed at the Pre-construction meeting shall be submitted to the Construction Program.

Refer to the Construction Manual for Preconstruction Meeting Guidelines.

## Traffic Control

Figure 2.2



During the construction work there will be barricades, lights, signs, and other traffic control devices which the Contractor must install for the protection of the work and provide safety to traffic. The Plans will specify what traffic control devices the Contractor must furnish and where they are to be placed. After they have been placed, the project Engineer will check their condition and location. Special attention should be paid that any permanent existing traffic signs that are to remain in place during construction are not blocked or in conflict with traffic control signs. If any major changes are needed, the Contractor will be advised. The Traffic Engineer will review the project for specification compliance and usually send a letter to the Region Engineer with copies to the Area Engineer and the Construction Program. Once signs have been properly located, your job is to make sure they are properly maintained during construction. The Contractor should be notified immediately if any signs are damaged or knocked down.

# CONSTRUCTION DOCUMENTATION

## FIELD DIARY

---

Use a black pen to write in the diary. Keep the diary up-to-date by placing all information directly in the diary. If you let it go, even for a short period of time or make notes on scratch paper, something of importance may be forgotten or lost.

A diary is a written record of what actually went on each day on the job. Keep your diary up to date and accurate. If there is ever any question about what went on or why something happened, the diary had better have the answers. As a rule, anything out of the ordinary should be recorded.

- Diaries are important when determining whether a delay is within or beyond the control of the Contractor.
  - The Contractor has a certain amount of time in which to complete his work.
  - If that time is exceeded, through no fault of the Contractor, he can be given an extension. If, however, it could have been avoided, the Contractor will have to pay a penalty.
- Complete and accurate diaries have saved the Department large sums of money.
- Incomplete diaries have also cost the Department a lot of money.

Each diary should contain:

- Date, project number, and weather
  - Be sure to put the project number on each page.
  - The weather should include high and low temperature for the 24-hour period, wind, cloud condition, and any precipitation.
- Kind and number of equipment working
  - D9 cat, patrol, air compressor, and mechanical tamper, scraper and water truck used during afternoon.
- Number of men and hours worked
  - 4 man pipe crew started 7:00 a.m. Shut down 6:00 p.m.
- Quantity and location of work and type of work
  - 196' x 36" backfilled at 126 + 73
  - 30" x 60" bedded at 173+47

- Undercut at 174+47
- Orders given and received and notation of written orders
  - P.E. requested additional moisture in backfill at 126+73, Contractor informed.
  - Written order regarding undercut at 173+47
- Rejection of materials or work
  - Two sections of RCP 36" at 148+50 were rejected because of damage in handling by Contractor.
  - Backfill at 126+73 rejected because too dry.
- Visitors
  - Personnel from the central office, FHWA, Regional office of the Contractor's office should be mentioned in the diary.
  - John Doe - FHWA
  - Pete Bigwig - Contractor's office
  - Paul Tester - Central Lab
- Types of soil
  - Give the general textural classification of the material. Sand, gravel, clay, claysilt, or shale.
- Where backfill for undercut was obtained
  - Give the location of material, particularly if the material was obtained on the project.
  - Gravel backfill for undercut at 192+12 obtained from Sutters pit.
  - Or clay backfill for undercut at 112+43 obtained from cut at Station 57+00.
- Any decisions and the reasons for them
  - Told Contractor to stop operations due to rain and excess moisture in soil.
  - Or accepted 91% density in backfill because pipe is a non-critical equalizer.
- Any major problems encountered by the Contractor
  - Contractor attempted to cut entire depth of cradle in one pass on 60" RCP, Poor pipe- cradle fit is resulting.
- Delays and the reasons for them.
  - No pipe will be laid for two days, crew assigned to another job.
  - Or - cat broke down at 1:00 p.m., crew out of pipe work until fixed.
  - Repaired - 4:00 p.m.
  - Or pipe operations stopped until more pipe is delivered.
- Any special methods used
  - Sheepsfoot used to compact backfill.
- Note of proper signing for detour at 173+47 placed at 8:00 a.m. 10/27/90 removed 6:00 p.m. for 10/27/90.
- Signs in accordance with specifications and plans.
- Place your signature and title.



Figure 3.1 Example Diary Sheet

**LEAVE WHITE PAGE IN BOOK**

*Monday – July 1, 2000*

*Clear High 79° Low 61 Low 61°*

*Wind 10-15 MPH*

*Work hours 7:00 AM – 6:00 PM*

*Equipment:*

*4 – Scrapers (6416)*

*2 – Push Cats (D9)*

*2 – Motor Graders (146)*

*1 – Disk*

*1 – Sheepsfoot Roller*

*2 – Water Trucks*

*1 – Backhoe*

*1 – Front-End Loader*

*Rough Grading Sta. 250+50*

*Finish Grading Sta. 125+60*

*RCP Placed at Sta. 310+15*

*Contractor instructed to fix broken signs at beginning of project.*

*Moisture test 143 failed. Contractor instructed to water and re-roll  
Deficient area.*

*Area Engineer on project.*

*T. Hanson*

## **EXTRA WORK AUTHORIZATION**

When a situation arises that may require the contractor to do work not covered in the Contract, it may be handled by "Extra Work Authorization".

All new items and force account work requires a written agreement with the Contractor prior to performance of the work. When new items are involved, the Region Office should be contacted before agreeing to a unit price. The Agreement between the Area Engineer and the Contractor is prepared on a DOT- 228. This agreement is the basis for subsequent Construction Change Order.

**Figure 3.2** Extra Work Authorization Example

DOT-228 (5/84)

SOUTH DAKOTA DEPARTMENT OF TRANSPORTATION

Extra Work Authorization No. 4

Project No.: NH 0012(56)298, PCEMS 2674  
County: Brown  
Type of Work: Grading and Interim Surfacing  
Contractor: Louiseau Construction, Inc.

---

You are hereby authorized and instructed to do the work described herein in accordance with the terms of the contract.

In order to place 24" RCP at Sta. 162+26, the contractor will undercut pipe \*20'x2'x130' and place permeable granular material similar to that used for drain tile to allow area to be blocked off, water pumped out and pipe laid. However, pipe will be backfilled with adjacent fill material.

\*Extra width because of unstable soil at this depth.

---

ACCEPTED: \_\_\_\_\_ AUTHORIZED: \_\_\_\_\_

BY: \_\_\_\_\_ BY: \_\_\_\_\_

\_\_\_\_\_  
(Title)

\_\_\_\_\_  
(Title)

## **FORCE ACCOUNT**

---

When the state and the contractor cannot agree upon a price in which to do extra work, the work will have to be handled by "Force Account" (9.5).

If force account work is to be performed, the following items need to be documented:

- All contractor employees working on the extra work item by name, classification, pay rate and exact number of hours worked.
- Payrolls for time period that covers the force account work and all contractor employees have to be shown on the payroll.
- All equipment used for the extra work (actual and standby time).
- All materials incorporated into the work . Invoices or other documentation will be required.

The requirements for record keeping vary greatly with the type of work being completed. The inspector needs to keep accurate, informative and complete records including, but not limited to, contractor employees working and hours worked each day, equipment being used, idle equipment, bills for material used, and any other pertinent items.

On the following pages is an example of required record keeping for Force Account Work.

**Figure 3.3** DOT210 Force Account

**DOT-210**

**FORCE ACCOUNT**

**DAILY LABOR RECORD**

Project No: F0212(48)267 PCEMS: 0438 Date: July 25, 2001

Type of Work: Grading, Surfacing, Perforated Pipe

Name	Start	Stop	Start	Stop	Start	Stop	Start	Stop	Total Hours
<i>Dan Wood</i>	4:30	7:30							3.0

Department of Transportation

Contractor

By: \_\_\_\_\_

By: \_\_\_\_\_

**Figure 3.4** DOT210A Force Account  
**DOT-210A** **FORCE ACCOUNT**

**WEEKLY LABOR RECORD**

Project No: F0212(48)267 PCEMS: 0438 Week Ending July 25, 2001

Type of Work: Grading, Surfacing, Perforated Pipe

Name	Classification	Gross Hours	Regular Hours	Overtime Hours	Reg. Rate OT Rate	Amount
Dan Wood	0-9	3	1.74	1.26	7.50 11.25	27.23
					TOTAL	27.23

DEPARTMENT OF TRANSPORTATION  
 BY: \_\_\_\_\_

**Figure 3.5 DOT211 Force Account**

**DOT-211**

**FORCE ACCOUNT  
DAILY EQUIPMENT RECORD**

Project No. F0212(48)267 PCEMS: 0438 Date: July 25, 2001  
 Type of Work: Grading, Surfacing, Perforated Pipe

Equipment	Operator	Start	Stop	Start	Stop	Start	Stop	Hours	Regular Hours	Overtime Hours	Standby Hours	Rate	Amount
B-612 Caterpillar Backhoe	Dan								1.5			57.86	86.79
	Wood	4:30	5:30	5:50	6:00	7:10	7:20				1.5	20.60	30.90
910 Caterpillar Loader	Dan								1.0			20.09	20.09
	Wood	5:30	5:50	6:00	6:20	6:50	7:10				1.5	6.75	10.13
D-6H Caterpillar Bulldozer	Dan	6:20	6:50						0.5			52.10	26.05
	Wood												
<b>Totals</b>													<b>\$173.96</b>

DEPARTMENT OF TRANSPORTATION

CONTRACTOR

BY: \_\_\_\_\_

BY: \_\_\_\_\_

**Figure 3.6 DOT212**

**DOT-212**

**FORCE ACCOUNT**

**DAILY MATERIALS RECORD**

Project No: F0212(48)267 PCEMS: 0438 Date: July 25, 2001

Type of Work: Grading and Pipe Installation

Type	Quantity	Invoice (Purchased) Affidavit (From Stock)	Rate	Amount
Sand	30.45 Tons	Hanson Const. 0061416	13.26/Ton	403.77
Rock	26.8 Tons	SD DOT Ticket #E69017	3.00/Ton	80.40
4" Perforated Pipe	70 L.F.	Hanson Const. 456385	1.53/L.F.	107.10
<b>TOTALS</b>				<b>\$591.27</b>

DEPARTMENT OF TRANSPORTATION

CONTRACTOR

BY:

BY:

Problem: Using the information provided on the preceding pages and Section 9.5 of the Standard Specifications complete the Example Force Account Worksheets Summary:

## **FORCE ACCOUNT SUMMARY**

---

Project \_\_\_\_\_

Contractor \_\_\_\_\_

Sub Contractor \_\_\_\_\_

A.1. Labor A.1. \_\_\_\_\_

A.2. 15% of Labor ((0.15x A.1.) A.2. \_\_\_\_\_

B. Bond, etc. \_\_\_\_% of Labor Only (\_\_\_\_x A.1.)\* B. \_\_\_\_\_

Excludes 15% for overhead

C.1 Material C.1. \_\_\_\_\_

C.2. 15% of Materials (0.15x C.1.) C.2. \_\_\_\_\_

D. Equipment D. \_\_\_\_\_

E. Subcontracting (if applicable) A.1.+A.2.+C.1.+C.2. only E. \_\_\_\_\_

Use table:

\$0 to \$1,000.....10%

\$1,000.01 to \$10,000....\$100 + 5% of excess over \$1,000

Over \$10,000.01.....\$550 + 3% of excess over \$10,000

F. Profit - 10% of Total Labor & Materials F. \_\_\_\_\_

(0.10x(A.1.+A.2.+B.+C.1.+C.2.))

Total Force Account (add all lines)= \_\_\_\_\_

\*Unless Contractor provides a documented percentage to use in this space, use 27.1% as per 2004 Spec Book. Therefore you would multiply A.1. by 0.271.

# HIGHWAY LAYOUT

## ROADWAY ELEMENTS

---

Basic elements of the roadway that are taken into consideration during the planning, design, and construction stages are:

- Vertical alignment
- Horizontal alignment
- Cross section
- Drainage

### Vertical Alignment

Vertical Alignment of the centerline of the roadway is shown on the plans for the project. Two profiles normally are shown (Figure 2).

Existing ground surface

Top of Subbase elevation or Sub grade elevations when no subbase is to be placed.  
Top of finished grade on urban projects.

These profiles are a representation of the rise and fall of the road without indicating whether the route is straight or curved.

NOTE: On a four lane divided roadway, the profiles are shown separately for eastbound and westbound lanes/southbound and northbound lanes.

### Horizontal Alignment

Horizontal Alignment is the route of the road, as it would appear on a road map. It involves curves and straight sections of road. The roadway is located in terms of a centerline and right-of-way lines (Figure 2).

### Cross Section

Cross Section of the final roadway is shown on the cross section sheets in the plans (Figure 3). The data shown for centerline placement, crown, side slopes, back slopes, ditch, and final roadway width guide the survey crew in staking the project. This data also will be used by the inspector to check construction progress and the completed roadway section.

Original radial survey shots are taken by the survey crew or by aerial photography prior to construction. Sections are cut at right angles to the centerline and are of sufficient length to include the full width that will be graded on each side of the centerline. The number of survey shots taken will depend chiefly on the irregularity of the ground.

After the project is completed, a final radial survey is taken by the survey crew to compute the total earthwork involved in the project or field stakes are used to determine the as-built quantities.

A reduction scale is provided on the plans for both the profile and cross section view. These scales usually exaggerate in one direction. This is particularly true with the vertical scale on profiles.

## **Drainage**

Proper drainage must be maintained during construction. This helps obtain a stable roadbed and minimizes the reworking of roadbed that is too wet. There should not be any large bodies of water standing on the sub grade after a heavy rain. It can soak in and cause problems if not properly dried out. Ordinarily, when the grade has been completed, the crown slope will take care of runoff. Contractors usually watch drainage conditions closely as heavy moisture that does not drain adequately can cause unnecessary and expensive delays.

The Contractor shall not begin earth moving operations in the third mile until placement of granular base material has begun in the first mile, or as specified in the plans.

Ditches and channels should be constructed and maintained in such a manner that will avoid damage to the roadway section. There should not be any large concentrations of water standing in ditches. A channel, through the section, should be maintained so that water will drain out and into a natural waterway.

### **Section 734 of the Standard Specifications states:**

The Contractor will be required to perform water pollution control measures in the sequence and manner outlined in the contract. Additional water pollution control measures found necessary after award of the contract, shall be performed at such times and in the sequence ordered.

At the preconstruction meeting, the Contractor shall submit for approval to the Engineer, a proposed schedule and method of operation for performance of temporary and permanent water pollution control measures.

The Engineer has the authority to direct the Contractor to provide immediate permanent or temporary pollution control measures to prevent contamination of adjacent streams or other watercourses, lakes, ponds, wetlands, or other areas of water impoundment. Such work may involve the construction of temporary structures, berms, dikes, dams, sediment basins, slope drains, and use of temporary mulches, mats, seeding or other control devices or methods as necessary to control erosion.

Pollutants used during construction shall be stored or disposed of where runoff will not carry them into streams or lakes. Pollutants shall not be disposed of in streams or lakes.

Contractor equipment yards and service areas shall be located or bermed so runoff from the areas and pollutants do not reach waterways or impoundments of water.

If conflict between these requirements and pollution control laws, rules, or regulations of other Federal or State or local agencies, the more restrictive laws, rules or regulations shall apply.



Erosion control measures shall be continued in an orderly and progressive manner to the extent considered feasible and justified.

**Figure 4.1**



Note: Erosion Control Manual is available to give a comprehensive look at erosion control measures.

## **TYPICAL GRADING SECTION**

---

The typical section (Figure 1) is a cross section of how the road is to be built.

There are three slopes on a typical section: backslope, inslope, and crown slope or crown rate. The angle that the inslopes and backslopes are at is given as a ratio such as 4:1. In this ratio the first number tells how many feet the slope goes horizontally to a 1' vertical change.

The crown slope is the rate that the road drops from the centerline to the shoulder. A typical crown slope would be 0.02' per foot. The purpose of this crown in the road is to provide drainage to get water off the road.

The Typical Grading Section will also show topsoil placement and undercut depth.

**Figure 4.2**

# TYPICAL GRADING SECTION

SOUTH DAKOTA	P 0073164137 P 0073144137	B20 B109
-----------------	------------------------------	-------------

Plotting Date: 25-JUL-2011

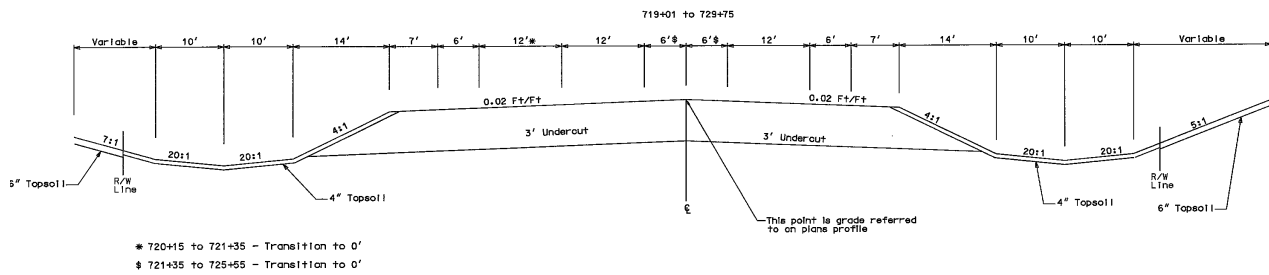
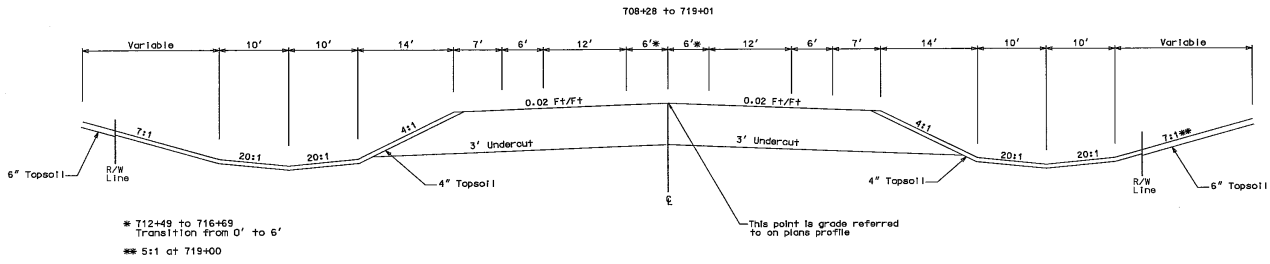

## CONSTRUCTION EQUIPMENT

Excavation is the removal of soil and rock from one location and hauling or moving it to another location. The major pieces of equipment used for excavation are as follows:

- Scraper
- Track Type Tractor (Bulldozer)
- Motor Grader
- Front End Loader
- Excavator (Backhoe)
- Water Truck
- Disk

### SCRAPER

---

Figure 5.1



The scraper is designed to remove a layer of soil from the ground surface and transport it to another location where it is deposited in a thin layer or stockpiled.

There are basically two types of scrapers; the tractor drawn and self propelled units. There are variations of these basic units presently in use. Some self propelled

scrapers have tractor units with four-wheel drive. Others may have a two-engine drive, one pulling and one pushing the scraper.

Scrapers are rated according to the cubic yards of material that the scraper bowl will hold. These may range from a few yards to 30 or more cubic yards.

Scraper units usually lack sufficient traction when loading, particularly when the material in the cut is hard. It is often necessary for additional motive power to be provided to the scraper unit. The pusher plate at the rear of the unit enables other tractors ("push-cat") to push the scraper and assist in the loading process. Under normal conditions only one "pusher-tractor" is used but when the material is very hard, the Contractor may need to use two "pusher tractors". Difficulty may also be encountered when unloading wet sticky clays or other materials, in which case a "pusher tractor" will be used.

**Figure 5.2**



## **TRACK TYPE TRACTOR (BULLDOZER)**

---

**Figure 5.3**



The bulldozer is probably one of the most versatile of the various equipment designed for earthwork. The wide crawler tracks provide stability and traction not available on other equipment. Therefore, it is an ideal unit to use as a "pusher tractor" for a scraper. It may also be used to pull rollers and discs as well as acting as

a surface-grading unit by spreading and leveling unloaded material with the bulldozer blade.

The bulldozer blade consists of a large curved steel blade held at a fixed distance in front of the tractor by arms secured on a pivot or shaft near the horizontal center of the tractor. The blade can be raised or lowered or tilted vertically. This blade has many uses such as backfilling, spreading, leveling, etc.

A ripper attachment may also be placed behind a bulldozer. The ripper has long angled teeth that are forced into the ground surface. They will normally rip the surface loose to a depth of 2' or more. Such attachments may have one, two, or three ripping teeth.

**Figure 5.4**



The bulldozer may also be used to pull a disk. A large disk may prove to be a very useful piece of equipment on a grading project and is required per specification, except for when A-3 or A-2-4 soils are used. It can be used to aerate or dry out wet spots, break down lumps of soil, mix the soil and help to get moisture into the soil evenly.

## **MOTOR GRADER**

---

**Figure 5.5**



The motor grader is a four or six-wheeled self-propelled grader. It has a long wheelbase, which will allow it to travel over uneven ground and to level it to an even

grade. The blade of the motor grader can be raised or lowered, rotated in a wide angle and tilted to different positions.

The motor grader is used to: level and spread the material as it is unloaded from the scraper, shape the slopes, cut ditches, perform the final grading, and many other operations.

The scarifier attachment on a motor grader is similar to the ripper attachment on a crawler tractor except the teeth are smaller. These teeth are used to loosen up the soil similar to a plowing operation. The scarifier can be set at various depths to obtain the desired depth of loosening.

## FRONT END LOADER

---

Figure 5.6



A front end loader is a tractor with a large scoop mounted on the front. It's used to load trucks with materials to be placed on the project. It may be used to remove any large rocks or other material that can't be handled by the scrapers. It's also used to scoop unwanted material (soft spongy soils or dark colored topsoil, which contain a lot of vegetation) from the roadbed.

## BACKHOE (EXCAVATOR)

---

Figure 5.7



A backhoe is a tractor with a bucket used to load material. It is used to load material into truck or scrapers or to remove topsoil or other material from areas in which a scraper cannot operate. It is used to dig trenches for pipe and box culverts.

## WATER TRUCK

---

Figure 5.8



The water truck is used to apply water to the soil in order to obtain optimum moisture. It may be a truck with a tank mounted on the back or a water wagon as shown.

## DISK

---

Figure 5.9



A disk is used to mix the soil to obtain a uniform sub grade. It may also be used to dry the soil to get it to optimum moisture.

Certain jobs may have specific requirements for some of the equipment. In this case, the specified equipment must be used unless otherwise authorized by the Area Engineer. If the Contractor wants to use a type of equipment other than that specified in the contract, he must submit a written request to the Area Engineer. The Area Engineer will advise you if approval is given.

When equipment to be used by the Contractor in performing the construction work is not specified in the contract, the Contractor may use any equipment that will produce a satisfactory-quality work.

## PRELIMINARY WORK

The plans will contain notes regarding miscellaneous structures already in place, old pavement, culverts, etc., that must be removed during the course of construction. The items to be removed usually fall into the following classes:

- Pipe and other salvable material
- Asphalt salvage
- Non-salvable material
- Steel bridges and related structures

### PIPE AND OTHER SALVAGEABLE MATERIALS

---

Pipe and other salvable materials that must be removed from the work area are noted on the plans. Observe this type of work closely. Pipe that is to be saved must be carefully removed and stored.

The following procedure is recommended for pipe removal:

Remove the overburden from the top of the pipe.

- Cut a ditch or channel on each side of the pipe.
- Remove the excess material along the sides of the pipe until the bottom of the pipe is reached.
- Lift each section of the pipe from the bed by a crane or other hoist arrangement.

Note: If extreme care is taken, it is possible to remove the dirt from the top of the pipe and cut a ditch on one side of the pipe, then carefully pull the pipe out.

The sections or pieces of pipe are then stockpiled in a place where they will not be damaged. The ownership of all salvable pipes is retained by the original owner of the road and may be used on that project or is taken elsewhere.



# ASPHALT SALVAGE

---

Figure 6.1



Existing asphalt pavement will be salvaged as per Specifications and/or plan notes. This is typically accomplished by use of a milling machine, which grinds the old asphalt or a combination of old asphalt and granular base off the existing roadway surface. It is then stockpiled, tested, and replaced or combined with other material for new surfacing.

## NON-SALVAGEABLE MATERIAL

---

Non-salvageable material is handled differently. Unusable, perishable material must be disposed of or buried outside the roadway at a location provided by the contractor. This will include unusable lumber, trees, brush, etc.

Non-perishable material, such as concrete pavement, asphalt pavement, curb and gutter, box culverts, basement foundations, etc., is broken up.

This is accomplished by using compressed air hammers, rippers, or other means capable of breaking up the material. The material is broken into pieces no larger than 2 square feet in size. These smaller pieces may then be used in the embankment sections as long as they are 1' or more below the sub grade and all voids are filled with compacted soil. Review plan notes as this is not allowed on some projects.

Non-perishable material should not be placed in a wetland or where the lowest point of the disposal site is located in ground water. The provisions contained in the current "General Permit for Highway, Road and Railway Construction/demolition Debris Disposal under the South Dakota Solid Waste Program" must be followed.

The contractor may choose to dispose of this nonperishable material outside the limits of view from the project, provided he has written permission from the property owner. A copy of this agreement with the landowner must be given to the Project Engineer. Review plan notes as some project will require that this be done.

The substructures of existing structures must be removed completely or broken down to the natural stream bottom. Parts of structures outside of the stream must be removed or broken down to at least 1' below the final ground surface.

After the removal of the sides of box culverts and concrete basements, holes should be drilled or cut into the floors. The holes can be made with a drill, air hammer, or other means cleared by the Project Engineer. These holes will serve as drainage channels that will help to drain off any water which might become trapped on these surfaces after they are covered by embankment material. This will reduce or eliminate any settlement that might otherwise result from the trapped moisture.

## **STEEL BRIDGES AND SIMILAR STRUCTURES**

---

Steel bridges and similar structures are usually taken apart and salvaged. The surfacing over these structures is usually removed before the structure is taken apart. The beams and girders are disassembled by either removing the bolts or removing the weld material with an air arc. If special procedures are to be followed, they are specified on the plans.

Procedures involved in the removal of structures such as wooden buildings, etc. are usually set forth in the right-of-way agreement. If removal isn't stated there, it may be shown on the plans. When no special procedure is specified, the removal or demolition will be directed by the Project Engineer.

# EXCAVATION AND EMBANKMENT CONSTRUCTION

## TOPSOIL

---

The Contractor will generally stockpile topsoil ahead of grading operations. Topsoil is defined as the humus bearing soil that will support plant life. The topsoil is usually removed with a scraper, typically to a depth of 6", stockpiled and later spread to make a seedbed in the ditches and on the slopes after normal grading operations are completed. (120.3)

- The Contractor should not be allowed to remove topsoil beyond the limitations stated in the specifications:
- The Contractor shall not begin removal of topsoil in a third mile until erosion control measures have begun in the first mile.
- Erosion control shall include placing seed, erosion control blanket, erosion bales and spreading topsoil.

The topsoil is salvaged from various places such as the regular grading area, plan designated areas, or areas designated by the Project Engineer.

- You are responsible to see that all objectionable vegetation, and debris such as rocks, brush, etc., is removed before the topsoil is salvaged.
- The topsoil is normally stockpiled within the limits of the right-of-way.
- If operations prohibit stockpiling the topsoil within the right-of-way, the Contractor must make arrangements for other locations at his own expense.
- The stockpile should be well shaped to assist in accurate measurements.
- If they are irregular or spread out, the survey will be difficult to obtain an accurate volume.

The inspector should observe and note where the Contractor places his topsoil stockpiles. You cannot direct him to place them in a specific spot, but you can avoid problems by discussing points with him that you see or suspect may cause trouble. Some areas of concern are:

- The Contractor should try to avoid placing the stockpile directly behind cut stakes. It's sometimes necessary to extend the cut area beyond the stakes for additional dirt. It is better to allow a few feet between the stockpile and the cut stakes. This

may be difficult when there is minimal space between the cut stakes and the R.O.W. line.

- Stockpiles built near a fill can cause a problem when there is extra dirt that must be wasted on the berms.
- Incorrect stockpile placement can block drainage.

When stockpiles are placed within the R.O.W., the best place is an area between where a cut section ends and a fill section begins. The Contractor can also make arrangements to use private property, (at his own expense).

The Contractor receives payment for placing topsoil. This payment is based on the quantity of material removed from the stockpiles and placed on designated areas. Have the survey crew cross section all topsoil stockpiles so that correct placement volume can be calculated. The separation of topsoil taken from cut areas and topsoil taken from embankment areas is not required.

The plans will specify the areas that are to be covered with topsoil. The plans also specify thickness to be placed. (See Figure 1) If there isn't enough topsoil available to do this, the Project Engineer may reduce the required thickness so the available material can be spread evenly over the required areas. The areas that are to be covered with topsoil should be smooth so that a uniform layer of topsoil can be placed. After placement, topsoil should be disked or harrowed to break up the lumps and provide a smooth seedbed.

**Figure 7.1**



The stockpile sites must be left in a neat and sightly condition after material utilization. The site should be free of small piles of soil, tire ruts, and other debris. Stockpile area should appear neat and smooth similar to areas of topsoil placement.

## **CUT SECTIONS**

---

Material to be removed from the "cut sections" may be classified as follows:

- Unclassified Excavation
- Rock Excavation
- Muck Excavation
- Undercutting

## **UNCLASSIFIED EXCAVATION**

---

Unclassified Excavation includes any and all materials encountered during construction regardless of their nature or manner of removal unless otherwise classified.

It may be noted on the plans that all excavation, except structure or muck excavation is included in "unclassified excavation."

The shaping of the roadway is started with the scraper removing the material that lies between the slope stakes at right and left of centerline. While removing this material in layers, the scraper operators will maintain the backslope noted on the slope stakes. These backslopes will be rough but will be smoothed out by bulldozers and/or motor graders. The blades are set at the required slope and used to plane off any excess material. This general procedure is maintained until the approximate typical section is obtained. During the shaping of the roadway, you must make periodic checks to see that the slopes are being constructed in accordance with the plans. These checks are explained in the "Grade and Slope Control Section."

When rock formations or hard clay layers are encountered that the scrapers can't move, ripping is usually begun. Ripping is a means of loosening these materials so the scrapers can load and move them. The ripper tooth is maintained at a constant depth so the breakage along its path will be uniform.

Scrapers are used during and after the ripping operation to remove the loose material. Front end loaders are used to remove the large rock that the scrapers can't handle.

## TABLE OF EXCAVATION QUANTITIES BY BALANCES

Station to Station	Excavation	Undercut	* Muck Exc.	* Option Borrow Exc.	* Borrow Unclassified Exc.	* Contract or Furnished Borrow	Select Subgrade Topping Exc.	Undercutting Select Topping	Total Excavation
(CuYd)	(CuYd)	(CuYd)	(CuYd)	(CuYd)	(CuYd)	(CuYd)	(CuYd)	(CuYd)	(CuYd)
xx+xx	xx	xx	xx	xx	xx	xx	xx	xx	0
xx+xx	xx	xx	xx	xx	xx	xx	xx	xx	0
xx+xx	xx	xx	xx	xx	xx	xx	xx	xx	0
Totals	E	0	0	0	0	0	0	0	0

Excavation	E
Undercut	xx
Undercutting Select Topping	xx
Select sub grade Topping	xx
Excavation Topsoil	xx
Exc. for RCBC Installation	xx
Exc. for Deep Pipe & RCBC Removal	xx
Added Detour Excavation	xx
Salvaged Asphalt Mix and Granular Base Material (from cut sections)	xx
Salvaged Asphalt Mix and Granular Base Material (from fill sections)	xx
Unclassified Excavation	0

\* The quantities for these items are in the Estimate of Quantities under their respective bid items.

When plan quantities are used for payment, the Unclassified Excavation quantity above shall be used for final payment. If final cross sections are taken in the field, add all of the above items using the following procedures:

Unstable material quantity is included in the Excavation quantity listed above. When finaling a project, the Unstable Material quantity shall be added to the Unclassified Excavation quantity.

The total quantity of field measured Topsoil shall be added to the Unclassified Excavation quantity. By doing this, the quantity of Topsoil from the cuts will be paid for twice as Unclassified Excavation. This will be full compensation for Excavation, which includes necessary undercutting to provide space for placement of topsoil.

The Excavation quantities from individual balances and the table above have been reduced by the volume of in place surfacing that will be removed.

When finaling a project, the estimated quantity of XXXXX cubic yards of Salvaged Asphalt Mix and Granular Base Material from fill sections only shall be added to the Unclassified Excavation quantity for final payment. The quantity of Salvaged Asphalt Mix and Granular Base Material from fill sections added to the Unclassified Excavation quantity shall be plans quantity and will not be adjusted according to field measurements. The quantity of Salvaged Asphalt Mix and Granular Base Material from cut sections will not be added to the Unclassified Excavation quantity as it is already in the cuts on the final cross sections.

OR (for Concrete Pavement Removal)

The volume of in place Concrete Surfacing removed will NOT be paid for as Unclassified Excavation.

The Excavation quantities from individual balances and the table above have been reduced by the volume of in place concrete pavement that will be removed.

When finaling a project, the estimated quantity of XXXXX cubic yards of Concrete Pavement removed from the cut sections shall be subtracted from the Unclassified Excavation quantity for final payment. The quantity of Concrete Pavement from cut sections subtracted from the Unclassified Excavation quantity shall be plans quantity and will not be adjusted according to field measurements.

	(Cu Yd)
Option Borrow Excavation	xxxxxx
Topsoil in Option Borrow Pits	xxxxx
	_____
Total Option Borrow Excavation	xxxxxx
	(Cu Yd)
Borrow Unclassified Excavation	xxxxxx
Topsoil in Borrow Pits	xxxxx
	_____
Total Borrow Unclassified Excavation	xxxxxx

## **ROCK EXCAVATION**

---

Rock excavation includes all hard rock in ledges, bedded deposits or unstratified masses that are so firmly cemented together that extraordinary measures, such as

blasting, must be performed for removal. Shale is not considered rock unless so designated on the plans.

Refer to the Standard Specifications Section 120.2.C for a detailed definition of rock excavation.

If the plans do not show the need for rock excavation (work which requires blasting) and rock is encountered, the Contractor must notify the Area Engineer in writing of his findings and request extra compensation. If the Area Engineer agrees that the Contractor is entitled to rock excavation, the survey crew will take cross sections of the area. After rock excavation has been completed, the survey crew will take final cross sections so the quantity of rock excavation can be calculated.

Blasting is a means of breaking up the rock through the use of explosives. It is used when the rock can't be broken up by ripping or through the use of other ordinary excavating equipment.

- When the use of explosives is necessary for the prosecution of the work, the Contractor shall not endanger life, property, or new work.
- The Contractor shall be responsible for all damage resulting from the use of explosives.
- The Contractor shall comply with all laws and ordinances, as well as with Title 29, Title 30 and the Code of Federal Regulations, Part 1926, Safety and Health Regulations for Construction (OSHA), whichever is the most restrictive, in the use, handling, loading, transportation, and storage of explosives and blasting agents.
- The Contractor shall notify property owners and public utility companies having structures or facilities in proximity to the site of the work of their intention to use explosives. Such notice shall be given sufficiently in advance to enable them to protect their property from injury.
- After blasting, the Contractor must clean up all debris and repair any damage resulting from the explosion.
  - He should take precautions to prevent flying rock and other debris especially in or near structures or inhabited areas.
  - Blasting mats will help. These mats can be constructed of tires or fence posts chained or tied together with cable. The mats should be laid over the entire area where the charges have been set.



**Figure 7.2**



Pre-shearing is a method used to establish a smooth face when rock is being blasted. It is accomplished through the controlled use of explosives.

- It usually results in a shear plane that coincides with the proposed cut slope.
- It is the preferred method and has additional advantages of leaving a cleaner looking slope that is easier to maintain as it reduces erosion and falling rock potential.

**Figure 7.3**

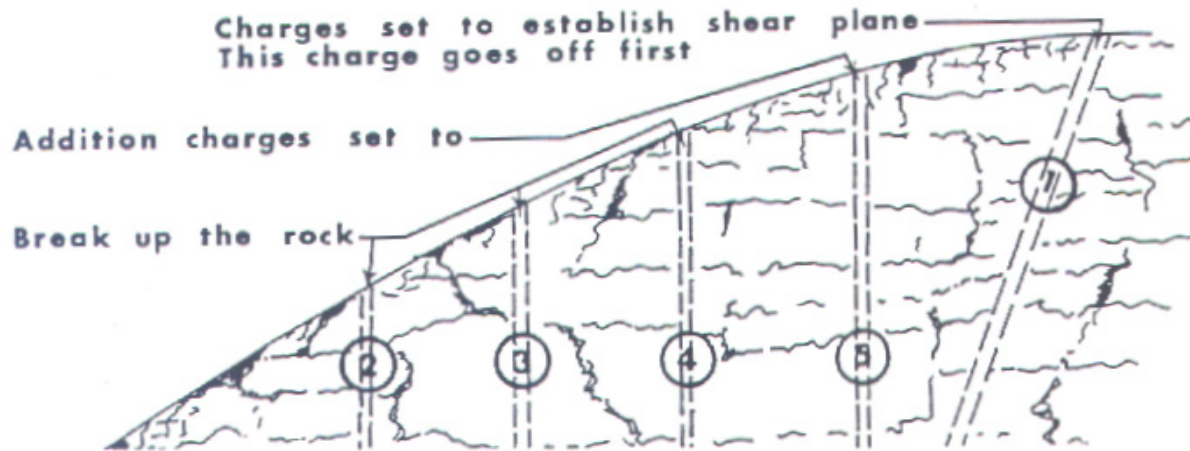

## MUCK EXCAVATION

---

Figure 7.4



Muck Excavation consists of the removal and disposal of saturated organic mixtures of soils and organic matter, which requires additional work or equipment not normally required for unclassified excavation.

The plan notes and cross sections will indicate areas of muck excavation.

## UNDERCUTTING

---

Undercutting is the process of removing material from its natural location to a specified depth below the plan sub grade elevation. The typical section (Figure 1) will indicate the depth of undercut on the project. There are various reasons for undercutting on grading projects. For convenience of explanation they will be called:

- Undercutting for replacement and recompaction to achieve uniformity.
- Undercutting to provide space for select material.
- Undercutting to remove unstable or unusable material.

Undercutting for replacement and recompaction is required when compaction requirements in the plans or Specifications are a specified amount. The reason for this type of undercutting is to disturb or break up layers and lenses of natural soils to provide a sub grade composed of material which is uniform, with a controlled density, for a specified depth below the finished sub grade elevation.

- Material, which is replaced and recompacted, may be the same as that removed.
- It may also be select material or a combination of natural and select materials.
- The depth of this type of undercutting can vary from project to project.
- The plans and specifications will specify the amount you need to undercut.
- The actual procedure the Contractor uses for undercutting is not specified. He may use any method as long as the undercutting requirements are met.

A set of field records to show that the work was actually accomplished needs to be filled out. Careful records will be required, when the Contractor does not remove the

entire length of undercut in one operation to assure that the entire undercut is removed and replaced.

If undercutting is not performed as directed by the Engineer, a station by station record will need to be kept, as this quantity will be deducted from plan quantity.

Undercutting to provide space for select material is required when the materials exposed by excavation are not suitable for the upper portion of the roadbed. The material is removed and a "Select Material" is put in its place.

- Select material is the best material available on the job for building the upper portion of the roadbed.
- It may either come from a specified area or other material that meets specified requirements.
- Individual job requirements may differ.
- Refer to the plans or ask the Project Engineer.
- The inspector must make sure this undercutting is accomplished to the depth required by the plans.
- The preferred way to check undercutting depth is to have the survey crew take cross sections of the area.

Undercutting to remove unstable or unusable material may or may not be anticipated on the plans. It will frequently occur below the excavation included in undercutting for compaction or undercutting for select material.

- This material may be bentonite and soft or wet spots.
- It must be removed to the depth specified on the plans or as directed by the Engineer.
- This removal is accomplished by stripping off the material to the desired depth using scrapers or bulldozers.
- This material is either wasted or used in certain areas of the embankment section.
- The amount of unstable material removed must be measured and recorded for payment purposes.

**Figure 7.5**

#### UNDERCUTTING TO REMOVE UNSTABLE MATERIALS

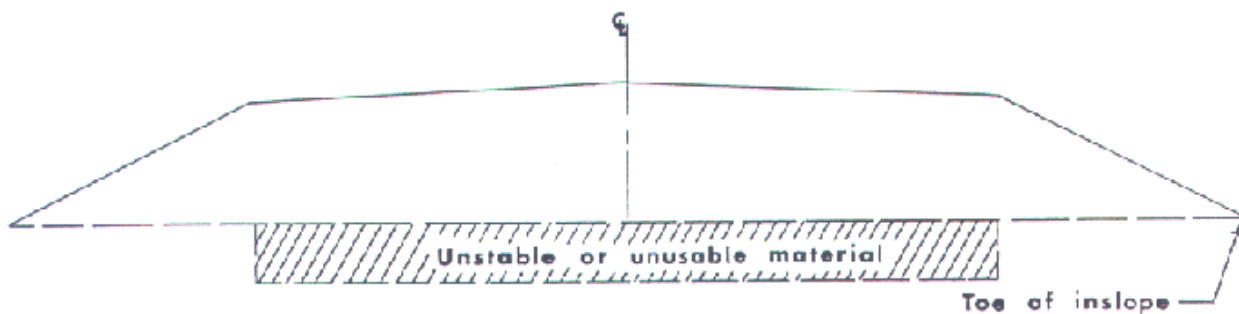

- Measurement may be by dimensions or survey crew cross sections before and after the unstable material is removed.
- Only small areas should use dimensions to calculate quantities (length x width x depth), lengths of about 500' or less.
- Larger areas should be cross sectioned.

It is a good practice to have the Contractor's representative initial the measurements taken for the undercutting and provide him a copy of the notes. When dimensions are used, a sketch is helpful for explanation purposes. After this material has been removed, it's necessary to backfill the excavated portion with suitable or select material.

**Figure 7.6** Example DOT-44B Field notes for undercutting

Undercut      Blue    Top 3 SD DOT	Undercut      Blue    Top 3 SD DOT
Page 6	Page 6

<u>20+00</u>	<u>Sta. 20+00</u>
	<u>Checked w/ Head Level</u>
<u>60.50 60.81 61.05 61.29 62.09</u>	<u>5/31/01 MJS</u>
<u>-27.6 -12.0 0.0 12.0 17.1</u>	
<hr/>	
<u>21+00</u>	<u>Sta. 21+00 to 21+50</u>
	<u>Checked w/ Head Level</u>
<u>60.80 61.10 61.34 61.58 62.48</u>	<u>5/26/01 MJS</u>
<u>-27.4 -12.0 0.0 12.0 18.3</u>	
<hr/>	
<u>22+00</u>	<u>Sta. 21+00 to 23+00</u>
	<u>Addtnl UC due to unstable conditions</u>
<u>60.95 61.40 61.64 61.88 63.11</u>	<u>5/31/01 MJS</u>
<u>-34.7 -12.0 0.0 12.0 21.4</u>	<u>200'x12'x2'</u>
<hr/>	
<u>23+00</u>	<u>Sta. 22+50 to 23+00</u>
	<u>Checked w/ Head Level</u>
<u>61.24 61.69 61.93 62.17 63.86</u>	<u>5/25/01 MJS</u>
<u>-34.7 -12.0 0.0 12.0 26.3</u>	
<hr/>	
<hr/>	
<hr/>	

## BACKFILLING

Backfilling is the process of replacing previously removed soil materials in undercut areas. Two kinds of backfill material can be used:

- The same or same type of material that was taken out.
- Selected material from a different area that is more suitable for the roadbed. The sources of select material should be noted and recorded in your diary (where it was obtained and where it was placed).
- The backfill material is usually placed by scrapers or trucks and compacted to a specified density.

## ADDITIONAL MATERIAL

---

It may be necessary to obtain additional material to supplement the material excavated from the normal job limits. Additional material may also be used to reduce the length of haul for the embankment construction.

A frequent cause for the need of additional excavation or excess material is an incorrect shrinkage factor. When the job is designed, a shrinkage factor is used to determine how much change in volume will result when the dirt is disturbed from its natural location and recompactd in another place. This shrinkage factor will be shown on your plans.

If additional material is required, it can be taken from the following locations:

- Additional Excavation
- Temporary Easement
- Borrow

### ADDITIONAL EXCAVATION

---

Additional Excavation is the extension or widening of the normal excavation areas (those proposed or provided for on the plans), as shown in Figure 7.7 below.

**Figure 7.7**



### TEMPORARY EASEMENT

---

Additional material can be taken from the temporary easement, which is outside the right-of-way, but is within the job limits. See Handout 8 for an example of a Temporary Easement Agreement.

If more material is required than can be taken from the Temporary Easement, additional Temporary Easement can be obtain to get additional material. Prior to expanding the Temporary Easement contact the Landowner to explain what area will be expanded. As per the standard agreement, additional easement can be obtained beyond the easement limits:

"It is further agreed and understood by the GRANTOR that any additional temporary easement area necessary for the proper completion of the facility may also be so used and the additional area will be measured and paid for separately at the same rate herein stated. It is agreed and understood that all areas used will be sloped and graded as smooth as practicable and left in a neat and workmanlike manner; and;"

The additional temporary easement shall be measured for payment for the acres used and for any crop damage in the additional temporary easement obtained by the State. The agreement also specifies fencing requirements and crop damage provisions.

## **BORROW MATERIAL**

---

There are two type of borrow material, they are:

1. Option Borrow - this type of borrow is obtained by the State and an agreement is signed between the Landowner and the State.
2. Contractor Furnished Borrow - this type of borrow is obtained by the Contractor and the agreement is between the Landowner and the Contractor.

## **OPTION BORROW**

---

Option borrow is that material, which is, obtained from optional areas outside the normal job limits.

The option borrow area is obtained by the State and an agreement is signed between the Landowner and the State for the use of the land and the removal of the material.

The payment to the Contractor for the option borrow material will be the amount of borrow material removed from the borrow site and the total topsoil stockpiled and replaced. To obtain the total Option Borrow quantity, the comparison between the original ground surface and the final ground surface will give the total amount of borrow material hauled to the project, by specifications this must be done by the average end area method. The salvaged topsoil stockpile will need to be surveyed to determine the amount of topsoil stockpiled, which will be added to the amount of borrow hauled to the project. Option Borrow is paid for by the cubic yard.

The Landowner will be paid a royalty payment for the borrow material hauled from the property to the project and various payments for the use of the borrow area which is stated on the Option Borrow Agreement.

The amount of royalty paid for the borrow material (only) that is hauled from the borrow site to the project shall be held back from Contractor.

**Figure 7.8**

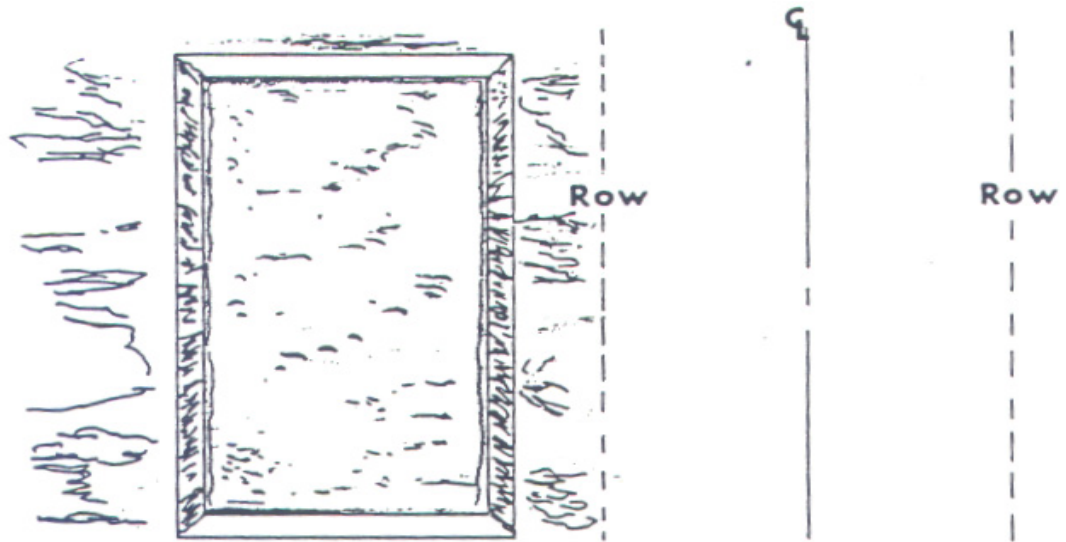

This material may either be obtained by digging a hole in the ground (dugout) or by cutting off the top of a hill.

**Figure 7.9**

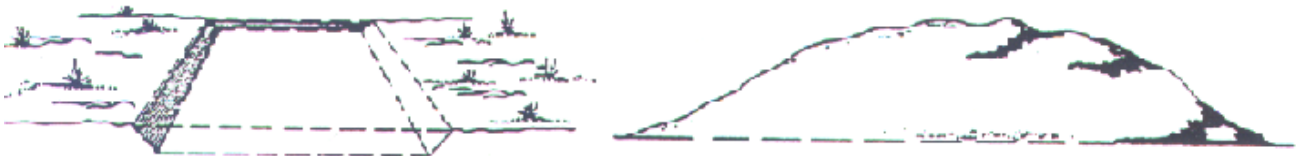

All normal excavation materials should be used before taking additional excavation. The operations involved in obtaining additional excavation are similar to that of the general excavation procedures. Scrapers may be used to load and haul the material or trucks and front-end loaders may be utilized. The Contractor may want to use trucks for a long haul because they are more economical.

During construction, the additional materials areas should be kept well drained. The additional materials site must be left in a suitable and sightly condition to permit accurate measurement. The sides and/or ends shall be sloped as indicated on the borrow agreement, plans, or as directed by the Engineer. The landowner must also be satisfied with the condition of the site.

Make sure that cross sections have been taken of all additional material areas before excavation begins.

The Plan Borrow Pit Information Sheet will show the location of the borrow pit. In addition, preliminary test data, log of pit, and other information will be shown (See Handout 6). Cross Sections will also be provided. The plans may have notes regarding Borrow Pit operations.

The Agreement to Sell Materials located in the Proposal will specify the requirements for the borrow pit such as:

- Depth of topsoil to be removed
- Fencing requirements
- Seeding requirements
- Other items as specified

## **AGREEMENT TO SELL MATERIAL PROBLEM:**

---

From the "Agreement to Sell Materials" on the following three pages and the information provided below determine the total payment due to the landowner:

Total Borrow: 58,378 Cu.Yds.

Topsoil: 4,937 Cu.Yds.

Acres Disturbed: 5.7 Acres



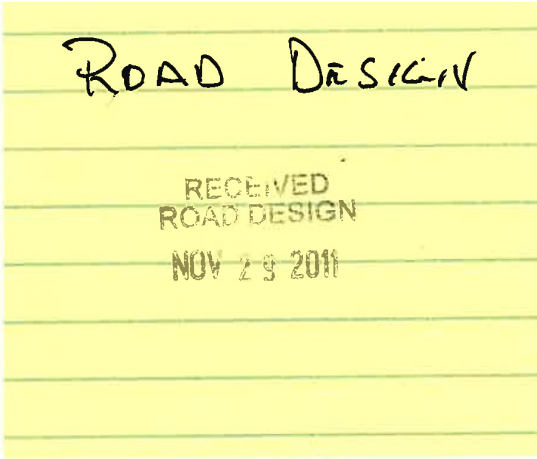

DOT-44B  
(06/2010)

**STATE OF SOUTH DAKOTA  
AGREEMENT TO SELL MATERIALS**

**Kevin R. Wald**, referred to in this Agreement as the "Owner" (whether one or more), for and in consideration of the mutual promises and agreements contained in this Agreement, the receipt and sufficiency of which is acknowledged, grants a **NON-EXCLUSIVE** option to the **State of South Dakota**, acting by and through its **Department of Transportation**, referred to in this Agreement as the "State," for the purpose of making the necessary tests for and purchasing borrow soil necessary for use in the construction, maintenance, and repair of highways. The Owner agrees to sell, transfer, and convey to the State such material located in and upon the following described real property situated in Hughes County, South Dakota, more particularly described as follows, to wit:

**All that part of Blocks 6, 7, 8, and 9 in National Addition, Hughes County, South Dakota, lying west of the right-of-way as defined in Book 257, page 119 in the Hughes County Register of Deeds office, and lying west of the highway.**

This Agreement is intended to allow the removal of **Borrow Soil**.

The term of this Agreement will be from **March 1, 2012**, to the completion of Project: **P 1804(12)251, PCN 02V1**.

The Owner agrees that the State, and any and all servants, agents, contractors, or workers authorized by the State, will have full and free right of ingress and egress from the public highway and will have the right to operate all necessary equipment on the real property herein described for any purpose allowed or required by this Agreement. The term "necessary equipment" will include equipment required to open the pit, produce materials, blend and mix with other materials, haul materials, service equipment, and restore the pit.

The State reserves the right to assign this Agreement to any party or parties performing the contracts for which the material will be required. Upon assignment of said Agreement, said party or parties will have all rights granted under this Agreement to the State and will assume all obligations of the State under this Agreement.

The State will pay to the Owner, from monies withheld from the Contractor, for material removed from said real property at the following rates, based on quantity:

First 0 – 10,000 cubic yards	\$ .30 (thirty) cents per cubic yard
Next 10,001 – 100,000 cubic yards	\$ .25 (twenty-five) cents per cubic yard
Over 100,000 cubic yard	\$ .20 (twenty) cents per cubic yard

The State will restore fencing disturbed by the State's operations under this Agreement to as good a condition as the fencing was in before work started. If a temporary fence is required around the pit to protect livestock, such fence will be erected at the expense of the State.

The State will operate the pit and will restore the affected area on completion of operations at the pit site in accordance with the General Provisions of "SOUTH DAKOTA DEPARTMENT of TRANSPORTATION STANDARD SPECIFICATIONS FOR ROADS AND BRIDGES" and the following:

1. The State will restore the affected area for use as pastureland.
2. Topsoil, to be stockpiled separately from the rest of the overburden, will be considered to consist of the upper six inches (6") of natural soil.
3. At the completion of removal operations, the State will restore areas disturbed by the State's operations at the pit site with slopes created by material removal left at 10:1 or flatter.
4. Prior to the beginning of the borrow operations, the Owner or the Owner's representative, the State's Engineer, and the State's contractor will meet and discuss the limits of work and pit operations.
5. The State will pay a one (1) time payment in the amount of \$100.00 per acre per year for two year(s) to cover loss of use of the real property.
6. The State will pay a one (1) time payment for crop damage at the rate of \$N/A per acre.
7. Seeding Options: Circle one of A, B, or C (Not applicable) (**Circle One**)
  - A. The State will seed and mulch the disturbed area one (1) time only to permanent seed mixtures as shown in the plans; or
  - B. The Owner will, after the State replaces the topsoil, re-vegetate or cultivate the area at a time and in a manner consistent with the Owner's farming operations and land use plan. The State will pay a one (1) time payment in the amount of \$N/A per acre to cover cost of such re-vegetation; or
  - C. Not applicable.
8. The Owner will remain responsible for controlling all weeds.
9. Other conditions: (if none, enter "none")  
None

This Agreement will be binding on the State, the Owner, and the Owner's successors and assigns.

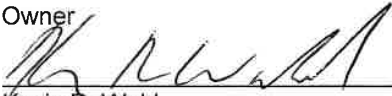
Owner  
  
 \_\_\_\_\_  
 Kevin R. Wald  
 121 N. 1<sup>st</sup> Street  
 Montevideo, MN 56265  
 (320) 269-3227 ext. 201  
 Date: 11/18/11

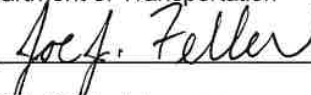
State of South Dakota  
 Department of Transportation  
 By:   
 \_\_\_\_\_  
 Its: Chief Materials and Surfacing Engineer  
 Date: 11-22-11

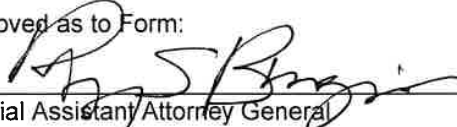
Approved as to Form:  
  
 \_\_\_\_\_  
 Special Assistant Attorney General

**ACKNOWLEDGMENT FOLLOWS**

OWNER'S ACKNOWLEDGMENT

State of MN )  
County of Chippewa ) :SS

On this the 18 day of November, 2011, before me, Kristi R. Stanley, a notary public, personally appeared Kevin R. Waid, known to me or satisfactorily proven to be the person(s) whose name(s) is/are subscribed to the within instrument and acknowledged that he/she/they executed same for the purposes therein contained.

In witness whereof I hereunto set my hand and official seal.



(Notary Seal)

Kristi R Stanley

Notary Public

My Commission Expires: 01-31-15

On rare occasions, The Contractor can choose not to utilize the Option Borrow site set up by the State and get a different borrow site. If this occurs, the Option Borrow quantity is remove and the bid item Contractor Furnished Borrow shall be added by CCO. The royalty payment to the Landowner will be made by the Contractor and no money will be held back from the Contractor by the State. The State will pay the Contractor the topsoil/refurbish cost for the plans Option Borrow.

## **CONTRACTOR FURNISHED BORROW**

This borrow site is obtained by the Contractor and the agreement for the borrow site is between the Landowner and the Contractor. The royalty payments shall be made by the Contractor and no payments will be held back from the Contractor. The payment for the Contractor Furnished Borrow is the total cubic yards removed from the borrow site to the project. No additional payments will be made for topsoil, loss of use of the land or refurbishing the borrow site by the State.

## **BORROW PIT RELEASE**

After the borrow site has been refurbished to the satisfaction of the Landowner, a Material Pit Release (DOT-44R) must be completed. This form must be signed by the Landowner, Contractor and DOT Representative.

## **DISPOSAL OF SURPLUS EXCAVATION AND WASTE**

---

Regardless of the source, surplus excavation and/or waste must be disposed of properly. "Wasting" is the process of disposing of material that cannot be otherwise utilized on the project or adjacent project sites. Surplus excavation material may have to be wasted when:

- Very heavy hill cuts must be made without a corresponding need for fills.
- Cuts and fills on a road are sometimes so far apart that combining them would cost more than wasting the surplus from the cuts and taking borrow nearer the fills.
- When material such as hard shale is dug or removed from its original position, it breaks up into particles or chunks that lie loosely on each other. This rearrangement creates spaces or voids and adds to its bulk. Unlike most soil, this material can not be compacted to less than it's original volume so; the excess must be wasted or otherwise disposed of.
- There are no special procedures for "wasting." If the waste areas are close to the project or within the right-of-way, scrapers or front end loaders may be utilized to move the material to the area. Trucks may be used, on a long haul, in moving the excess material to the waste area.

In some instances, a Waste Disposal Site will be provided in the plans (Handout 7). In these instances, an agreement will be provided in the proposal, and these provisions must be followed.

Low spots or areas that have no value are sometimes used for the disposal of surplus excavation or for the wasting of materials unsuitable for fill construction. Prior to placement of waste in low areas, make sure that the area has not been designated as a wetland. Waste may also be disposed of by flattening the inslopes or by placing it on the backslopes if no other waste area is available. No excavation is to be wasted in this manner without the permission of the Engineer. When this method is used, the material must be placed so it will present a neat appearance and not interfere with further improvements of the road. It must not obstruct drainage patterns, damage adjacent property, or disrupt snow storage areas.

If using borrow or extra excavation causes waste of mainline excavation, the volume wasted shall be deducted from the volume measured in the borrow area.

The approximate amount of waste, where it came from and where it was placed should be recorded in your diary.

## **EMBANKMENT**

---

Embankment (fill) has been referred to as the material that is placed between the original ground surface and the top of the roadbed. This material is obtained by excavating the following:

- High spots
- Ditches or other areas
- Borrow pits

Roads in hilly country are often designed to balance the cuts and fills. The material cut out of high spots is just enough to build up all the low spots. Sometimes the cuts are kept to a minimum and materials from borrow areas is hauled in. This happens when quality material is available near the fill area and the road crosses ridges of hard rock close to the surface, or where snow removal problems would be severe if excessive cuts were made.

### **PLACEMENT OF EMBANKMENT**

Embankment material is hauled to the roadway by the scrapers, or trucks. The material is spread and leveled in specified layers or lifts by motor graders and bulldozers.

### **PREPARATION OF THE ORIGINAL GROUND SURFACE**

Make sure the area is ready before the Contractor starts building the fill. The following procedures should be followed when making the "ready for fill" decision.

Soft Spots – Walk or drive the area where the fill is to be placed. Look for soft spots. If you find any that will have less than 4' of fill over them, the Contractor must dig them out. The soft spot should be dug out until solid material is reached, but do not dig below a point 4' below the top of the fill. If the area at the 4' level is still wet or mucky it must be corrected.

Before the Contractor starts digging, request the survey crew to cross section the area. Have them cross section the area again after the soft spot has been dug out.

In other places that are wet or soft, but will have more than 4' of fill over them, the Project Engineer will decide what needs to be done.

Steep Slopes – Whenever the embankment is to be placed and compacted against an existing slope that is steeper than 4:1, the Contractor must "*bench into*" the existing slope. No specific distances are established for these benches but in order to get a good tie into the existing slope it is preferred that the horizontal distance on each bench should be 4' to 6' (Point A). Each horizontal cut should begin at the intersection of the original ground and the vertical side of the previous cut (Point B). The material that is cut out to form these benches is placed and recompacted along with the new embankment material.

**Figure 7.10**

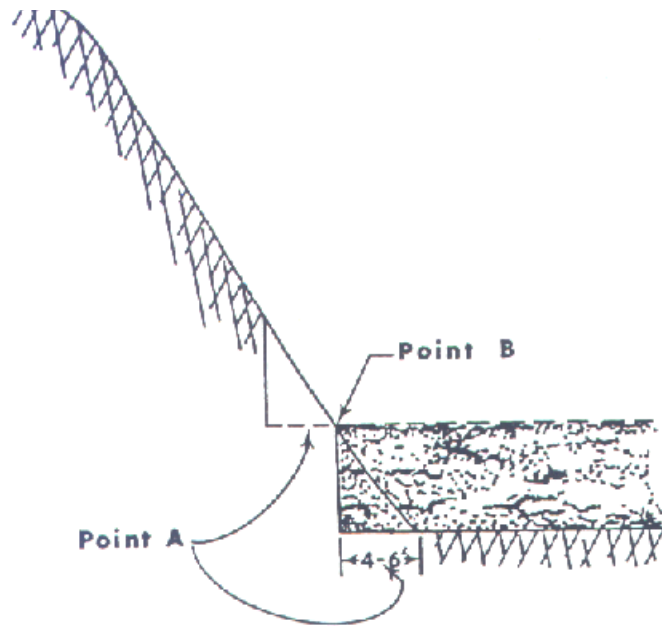

Embankment Undercut – Either the plans or the Specifications will state how much undercutting must be done. This usually applies to the shallow fill areas or an area where a certain depth of material must be reworked. The Contractor can do this any way or any time as long as the requirements are met.

Remember to take the proper measurements or cross sections to document the quantities for dig-outs and the undercutting.

After undercutting is completed, suitable material has to be placed into the undercut area. This material must be compacted to the density specified for that portion of the project.

Sod, which is not removed with the undercutting, shall be thoroughly disked. When undercutting is not required and an existing compacted road surface containing granular material lies within 3' of the sub grade surface, the old road surfacing shall be scarified to a depth of at least 6" and recompacted.

## **TYPES AND PLACEMENT OF EMBANKMENT MATERIAL**

Certain kinds of soil are more desirable than others for building embankment and certain jobs will have definite requirements for the upper portion of the fill.

The most desirable materials are mixtures of two or more types of soil. This can be done by using and mixing varying amounts of clay, silt, sand, gravel, or small rock.

Lightweight soil with substantial sand or gravel is excellent when the work is done in a rainy season. This material provides better traction than other types.

Sand or loose clean gravel has satisfactory bearing power but it doesn't stick together well. It's also difficult to compact. These soils usually require special attention during grading operations. Consult your Project Engineer for the correct procedure.

Topsoil and sod used in the embankment must be well disked and pulverized. It can be placed in fill slopes outside the shoulder of the sub grade or spread evenly over the full width of the cross section at least 4' below the top of the sub grade. Do not permit use of sod or topsoil within 10' of pipe and 50' of box culverts or bridges.

Humus and decomposed organic material should be avoided, particularly in its pure state, because of its lack of bearing strength and excessive water absorption.

Shale or silt soils generally are undesirable since the shale will soften when wet and frequently changes in volume. Silt may act as a wick to bring ground water to the surface of the sub grade.

The following should not be used in the embankment: frozen soil, ice, trees, stumps, rubbish, or other perishable materials in the embankment

The procedures involved in the dumping and spreading of the embankment material will depend on the type of equipment the Contractor has and the type of fill material being used. Unless otherwise specified, fills are built in layers, one on top of the other, for the full width of the roadbed. Equipment must be sufficient to meet the moisture and compaction requirements and to obtain uniform, well-mixed layers. The depth of these layers can be regulated by the following criteria:

Earth material must be placed in horizontal layers, which do not exceed 8" (loose measurement), with the following exceptions:

- Layers may exceed 8" provided the Contractor has equipment, which will obtain the required density for the full depth of the layer.
- When the material consists mostly of rock fragments, the lifts can be spread in layers equal to the average size of the larger rocks or 3' whichever is less. No specific density is required in these rock layers but bulldozers, blades, or other suitable equipment must be used to level and distribute the rock to prevent void spaces. These rock layers must not be constructed above an elevation, which is 1' below the finished sub grade.
- The top 6" of all embankments must be essentially free of rock fragments or stone that cannot be hand-passed through a 4" square opening.
- Embankments constructed through lakes and swamps may be constructed by end dump methods to an elevation that permits the use of normal construction methods

Each layer must be compacted as specified before the next layer is placed. Heavy construction equipment should be routed uniformly over the entire surface of each layer. Avoid heavy equipment continually following the same path.

Water will be added to meet the moisture requirements for the different types of soils and is covered later on in the manual.

## **EARTHWORK BALANCE**

---

The earth, which is excavated and borrowed, is to be used for embankment. The amount of Excavation and of Embankment should *balance* in a Balance Area.

The bottom half of Figure 2 is called the profile. On the top part of the profile are notes about Excavation (cut) and Embankment (fill) quantities. The part of the project covered by one set of notes is called a balance area. The limits of the Balance Areas are shown by long arrows along the top edge of the profile. These point to the balance points. Stationing is indicated above these balance points.

What are the balance points shown on Figure 2?

- \_\_\_\_\_
- \_\_\_\_\_

The quantities for the balance are shown between the balance points. The Excavation must equal the Embankment.

The Excavation quantities include all items where material is cut from the existing ground. These items include:

- Unclassified Excavation
- Undercut
- Borrow
- Muck Excavation

The Embankment quantities include the materials placed to build the new roadway. These items include:

- Embankment
- Shrinkage
- Undercut
- Waste

A *shrinkage factor* is added to all embankment quantities to account for the estimated shrinkage that the material will encounter during construction. The shrinkage factor is an estimate based on preliminary testing of the excavation materials.

Example: Compute total excavation using the information given below.

Embankment 15,250 Cubic Yards Answer \_\_\_\_\_

Shrinkage 24%

## HAUL

---

The amount of haul and the average project haul can be found most of the time in Section B in the HAUL note. These numbers are computed to give the Contractor a means of estimating the distance the material will be hauled on the project.

The amount of total project haul is listed in units called Cubic Yard Station. The average haul is listed in Station (Sta.), a Station is 100 feet.

If the set of plans for the project doesn't have what the HAUL note, then the Estimate of Quantities table should have both an Unclassified Excavation and Haul quantity. To determine the average haul for the project divide the Haul by the Unclassified Excavation as shown below:

ITEM	QUANTITY	UNIT
Unclassified Excavation	1,814,541	CY
Haul	11,458,900	CYSTA

Average Haul = 6.315 Stations (631.5')

## Extra Haul

There are times when a Contractor will be required to haul material from another balance into the balance in which you are working. In these instances you must keep records of where the material is obtained and where it is placed. Keep track of the quantities by keeping a load count of the scrapers hauling material.

The Special Provision Regarding Price Schedule for Miscellaneous Items shows the rate at which Extra Haul is to be paid:

EXTRA HAUL COMPUTATION:



Material obtained from Sta. 530+25 to Sta. 534+25

Material placed from Sta. 515+00 to Sta. 518+00

Cubic Yards Hauled - 2500 CY

Average Project Haul - 6.315 Stations

Price for Extra Haul - \$0.04/CYSta.

530+25

534+25

1064+50          106,450/2 = 53,225

515+00

518+00

1033+00          103,300/2 = 51,650

53,225 - 51,650 = 1575/100 = 15.75 Stations

100

Haul          15.750 Sta.

Average Project Haul          6.315 Sta.

Extra Haul          9.435 Sta.

2500 CY

x 9.435 Sta.

23,587.5 CYSta.

23587.5 CYSta.

X \$0.04/CYSta.

\$943.50

## COMPACTION OF EMBANKMENT

---

As the material is being placed and spread on the fill area, it is necessary to compact the material. Compaction compresses the soil particles and results in a higher soil density – that is, more weight per volume. Along with the hauling equipment, rollers can be used to obtain the required density.

The different types of rollers and their application are:

- Sheepsfoot
- Pneumatic-tired
- Vibrating self propelled roller

The sheepsfoot roller consists of a watertight metal drum, which has metal studded teeth on the outside. The teeth on the surface of the drum resemble and function like the feet of the animal it was named for.

- The teeth compact the soil as the roller travels over the area.
- The teeth are designed to pull out of the material without disturbing it as the drum moves ahead.
- These rollers are either pulled by a crawler tractor or are self-propelled.
- The sheepsfoot roller compacts from the bottom of the lift up to obtain density.

**Figure 7.11**



Pneumatic-tired rollers consist of a series of rubber tires and a box containing ballast. The amount of compaction obtained with a rubber-tired roller can be varied by increasing or decreasing the tire pressures, which reduces or increases the square inches of tire surface touching the road.

- The sheepsfoot roller does not leave a completely smooth surface.
- The top surface of the subgrade is usually rolled with a pneumatic-tired roller.
- The pneumatic roller compacts from the top of the lift down to obtain density.

Two other types of rollers are often used.

Tamping foot rollers combines the advantages of the sheepsfoot and steel wheel.

- The tamping foot roller compacts from the bottom to the top of the lift like a sheepsfoot and from the top of the lift like the steel wheel or pneumatic rollers.

Vibratory rollers operate on the principle of particle rearrangement to decrease voids between particles. This is caused by the dynamic forces generated by the vibrating drum hitting the ground.

- Vibratory rollers are most effective on granular and mixed soil materials.

The sheepsfoot roller performs satisfactorily in most areas except; sandy or gravelly soils, close to abutments, and culverts. Compaction on these must be obtained by some other means or device (e.g. rubber tired roller, small rollers, or air tampers).

The movement of the Contractor's hauling equipment when building an embankment, should be monitored so that a uniform amount of compaction is obtained. The tire tracks should be spread uniformly over the entire width of the embankment. Modern day earth moving equipment weighs many tons and accomplishes considerable compacting as it moves along the road. If this equipment

is allowed to travel over the same area of roadway constantly, over-compaction will result in that area.

- Density is often obtained without using any rollers, as the compactive effort of the scrapers may be enough to obtain density.
- All soft spots, which develop in the sub grade during rolling operations, should be dug out. The material taken from the hole should be reprocessed or replaced and recompacted. No additional pay is made for this type of work.
- When embankments are to be placed through lakes or swamps, the embankment must be built by end dump methods until its high enough to start normal construction methods.
- One of the end dump methods is a process in which the soil is pushed over the end of a fill and allowed to roll down the slope into the water or mud.
- This is continued until a suitable embankment has been built to give the equipment a working foundation above the water and mud.
- Care shall be exercised so as not to entrap mud into the fill.

## **SURCHARGE**

---

In instances where it is felt that the entire grade will settle over time, the plans may indicate that additional material be placed on top of the subgrade. This additional material is called surcharge. The surcharge places additional load on the subgrade to facilitate a uniform settlement of the area. The material is typically removed on a separate contract at a later time.

Refer to Figure 5 for an example cross section.

## **DENSITY**

---

The degree of compaction of the roadway is controlled by either of the following methods:

- Specified Density
- Ordinary Compaction

### **SPECIFIED DENSITY**

---

Specified Density is obtaining a specified amount of density. The required amount will be shown on the Plans or Specifications. The compaction achieved is determined by an in-place density test. The procedures and requirements are given in the South Dakota Materials Manual.

When the embankment material contains a high percentage of rock, in-place density tests tend to be unreliable. If more than 40% of the material passing an 8" square opening is retained on the  $\frac{3}{4}$ " sieve, the specified density requirements will be waived. The embankment shall be compacted with sheepsfoot or other approved rollers to the satisfaction of the Engineer.

### **ORDINARY COMPACTION**

---

Ordinary Compaction allows the use of any type of equipment, which will give uniform, satisfactory results. A rolling procedure is established which will produce the required density. Refer to Section 120.3.B.3.b. in the Standard Specifications.

- Sufficient density tests are taken to insure that the required density is being obtained with the equipment and procedure being used.
- Once the procedure has been established, no further density tests are needed.
- Each layer must be satisfactorily compacted, to an unyielding state, before another layer is placed over it.
- Cut sections that have been excavated and backfilled must be compacted in the same manner as the embankments.
- The full roadbed width in completed cut-sections must also be compacted.

## MOISTURE CONTENT

---

The moisture content of the soil is a very important factor in obtaining the required density. To obtain proper compaction, it is necessary to place the soil in layers that are thin enough to permit the air and water in the soil to be forced out easily. The compaction of soil particles requires movement of the individual particles, or groups of particles, in order to fit them together and fill in the voids (empty spaces between soil particles). Before such movement can take place easily, friction between the particles must be reduced. Lubrication of the soil particles by means of moisture will reduce this friction and thereby decrease the effort needed to overcome the friction. Too little moisture will not reduce enough friction and too much moisture means that the excess water must be forced out. An ideal moisture content for soils that will facilitate compaction is desired. It is called the Optimum Moisture Content. This moisture content will vary considerably for different types of soils and the amount of compactive effort applied.

The maximum density of a soil is obtained with the least effort when it is compacted at its optimum moisture content as determined by a standard compactive effort. This is because the soil particles move easily to fill in the voids and there is no excess water in the compacted result. Therefore, it is desirable to compact embankment and sub grade sections that have reached or are very near the optimum moisture content. The result is a dense, stable foundation that has been uniformly compacted and is capable of supporting the surfacing courses that will be placed later.

Moisture control will be required for the compaction of each layer of the entire embankment. Optimum moisture is determined by Test # SD 104 (Proctor test). The optimum moisture content is the definite moisture content at which the soil being tested will compact most readily to its highest density. This optimum moisture content varies considerably for different soils.

Water is applied to embankment as needed to obtain the required density and meet the moisture content specifications. Various types of tank truck distributors equipped with watering devices can be used to apply water.

After water has been applied, it must be mixed into each lift of soil. This is accomplished by one or both of the following methods:

- Disking
- Blading with a motor grader
- Ripping with water wagon

The moisture content of the material should be uniform throughout the entire layer. When excess moisture gets into the material, by over-watering or natural causes (rain, etc.); it must be removed by some type of drying operation. The drying can usually be done in the same manner as the mixing operation – disking and/or blading the material back and forth across the roadbed. The drying under these

circumstances must be continued until a suitable moisture content has been reached, as a part of the contract work and without additional compensation.

The Contractor will normally regulate his operation so that a minimum amount of evaporation loss will occur. It is not in the State's best interest to pay for water that just evaporates. The operation should be such, that as water is applied, it will be mixed into the soil as soon as possible. If a major delay occurs in the mixing water and material procedure it may indicate the Contractor is working an area greater than his equipment can handle. This situation can be corrected by either reducing the mix area or by adding equipment.

No watering of embankments, or use of soils moist enough to incorporate in embankments without watering, can be permitted during freezing weather. Over night freezing temperature – If embankment area is built during the day when temperatures all above freezing but overnight temperatures fall below freezing, have the Contractor place a day lift over the embankment area. When starting up the next day have the Contractor process the day lift with water and rolling before they start hauling again. Constantly check to see if the moisture in the soil is freezing. Look for frost or ice lenses forming in the soil. Other, special considerations and work is necessary when placing soil during freezing weather to prevent frozen material from remaining in the embankment.

Keep a record of all water used on the project for grading operations. This can become somewhat difficult, as there may be several watering jobs ongoing at different locations. In order to maintain a close check on all watering operations, enlist the assistance of other state employees on the job site, to watch for loads being dumped or spread in unauthorized places. This general procedure can eliminate many potential problems when known by the Contractor and his crew.

Water used on the project is measured by the thousand gallons (M gal. or m<sup>3</sup>) complete in place on the project. Measurement is usually made by the number of full tanks of known capacity used on the work. Region Materials personnel will determine the capacity of each water tank used on the project and the truck so stamped. If a water tank is brought onto the job without the required capacity stamp, you should notify the Region Materials Engineer. Allow the Contractor to use the tank and keep a record of the number of loads of water hauled. Then after the Region Materials Engineer has determined the capacity of the tank make the required water tickets.

Be sure to record in your diary that this was the procedure you followed.

Things to watch for is that the water tank is completely emptied and completely filled to assure the correct amount is being recorded for payment. Unauthorized use of water is not paid for.

Water tickets are made, in duplicate, for all water used, each day. There are various ways of recording water loads:

- Make out a ticket for each load.
- Keep a tally sheet and make out one ticket for all loads hauled by each unit (water tank). When a tally sheet is used, the date, tank number, and your name must be placed on it. Retain this tally sheet even after making out the tickets.
- A third method of handling the daily water tickets would be:
- Each day – make out a water ticket for each "water tank."
- Fill out all applicable information except the M. Gals. (m<sup>3</sup>) and your name.
- Make a "hash" mark for each load dumped in the section at the bottom of the ticket, (in the "Remarks" area).

- At the end of each day or when the section is completed, add up the number of loads hauled. Multiply the number of loads by the M. Gals. (m<sup>3</sup>) capacity stamped on the unit. Put the answer in M. Gals. (m<sup>3</sup>) space on the ticket. Sign the ticket.
- Retain the original ticket and give the duplicate to the Contractor.

Figure 7.12

DOT 75  
(1-84)

## SOUTH DAKOTA

**MATERIALS AND WEIGHT TICKETS**

PROJECT HH 0014 (67) 254  
 MATERIAL Water  
 DATE 7-11, 1999 SAMPLE NO. \_\_\_\_\_  
 TANK OR CAR NO. 402 M. GALS. 35.7  
 TRUCK NO. \_\_\_\_\_ LANE \_\_\_\_\_  
 GROSS WT. \_\_\_\_\_ SECTION \_\_\_\_\_  
 TARE WT. \_\_\_\_\_ STATION \_\_\_\_\_  
 NET WT. \_\_\_\_\_ SPREAD \_\_\_\_\_  
 TONS \_\_\_\_\_ END STA \_\_\_\_\_  
 WEIGHER \_\_\_\_\_ CHECKER Joe Hess

---

CONCRETE MIX (TREATED MAT'LS) WATER: MAX \_\_\_\_\_ ACTUAL \_\_\_\_\_  
 TIME START MIX \_\_\_\_\_ BATCH DISCHARGED \_\_\_\_\_ SIZE \_\_\_\_\_  
 REVOLUTIONS: RATE \_\_\_\_\_ INSPECTORS: \_\_\_\_\_  
 FINAL INITIAL \_\_\_\_\_ PLANT \_\_\_\_\_ NET \_\_\_\_\_ PLACING \_\_\_\_\_

REMARKS: HH 11 @ 5.1 MGAL PER LOAD

No. D <b style="color: red;">931467</b>	BOOK QUANTITY
	PREV. TICKET <u>324.1</u>
	THIS TICKET <u>35.7</u>
TOTAL <u>359.8</u>	

LEAVE THIS SLIP IN BOOK

## PREWATERING (PRE-IRRIGATION)

Another method of adding water to material is "Prewatering." This is the process of applying water, through the use of irrigation sprinklers, to bring the moisture content of a cut area to its optimum before the material is excavated. If the proper procedures are followed, the material can be excavated and placed directly in the fill and compacted without adding additional water. This type of watering is seldom used but is an option available to the Contractor.

- Prior to prewatering, the Contractor must drill test holes to the depth and spacing specified by the Engineer over the area to be watered, to determine the amount of water to be applied.
- Test holes are drilled after watering to measure water depth.
- The field carrying capacity of a material is very near its optimum moisture content.
- Each layer of soil retains the water necessary to reach this condition and the balance will soak downward until all of the water is used up.

- Adjustments in the amount of water applied or paid for will be made for rain, excessive evaporation, runoff, or watering too deeply.
- To minimize runoff, natural vegetation is left in place until watering is completed.
- If vegetation is gone or is sparse, the area should be ripped to a depth of at least 2'. The rate at which water is absorbed may vary.
- Application should be slow at first and increased until the ground will not absorb it any faster.
- The vegetation is stripped off after watering, usually within 10 days.
- This is done to prevent vegetation from utilizing the moisture that has been applied.

The quantity of water applied will usually be measured by a meter. Meter readings are taken each day and entered on a water ticket (DOT-75) or in a daily entry in CM&P. This will be the source document for pay quantities.

## **COMPACTION DEFICIENCIES**

---

Failing tests for compaction generally result from a lack of water or lack of rolling. If, after testing the material, it is found that the water content is low, additional water must be added to obtain the required degree of compaction. If the water is found to be sufficient the next step is to assess the compactive effort. The following procedures may be used individually or in combination to correct compactive efforts:

Check the thickness of the layer to be compacted. It may be too deep for the rollers being used.

Have the Contractor decrease the depth of the lift for the soil layers  
and/or

Increase the number of passes of the roller(s) or add additional units of equipment.  
and/or

Increase the weight of the roller(s).

## CONSTRUCTION STAKES

Stakes are used to guide the Contractor in construction and to assist the inspector in checking the Contractor's performance. There are several types of construction stakes and reference points that the inspector should be able to recognize and use during the course of construction. Typical stakes found on the project are:

- Control Points
- Benchmark
- Hub Line
- Right-of Way
- Reference
- Offset
- Slope Stake
- Final Grade (Blue Top)

### CONTROL POINTS

---

A control point is an established point with a known coordinate (most control points will also have a known elevation). The control points are used by the survey crew to stake the alignment of the roadway.

### BENCHMARK

---

A benchmark is an established point of known elevation. This point is used for the determination of elevations of other points – final elevation of sub grade at centerline, flowline for pipe placement, etc. Benchmarks are set by the survey crew along the entire length of the project and their location and elevation are shown on the plans. Refer to Figure 2 and find the example shown below:

B.M. #50A Elev. 2738.22

IP & Gds 134.9'R

Sta. 514+27.15

Benchmarks are usually iron pins driven into the ground. Guard stakes are driven about 1' from the iron pin to protect it during construction. The benchmarks should be located away from the work area to prevent damage or destruction. Additional



markers may include a sign such as "DO NOT REMOVE" or a flag on a lath sufficiently above the ground to aid in quickly finding the point and to warn the equipment operators that a permanent point is present.

Most benchmarks are placed during the original survey of the existing roadway. To ensure that benchmarks have not been damaged, prior to utilizing any existing benchmarks a benchmark level check shall be completed on all benchmarks. The procedure for this can be found in the Survey Manual in Chapter 3.

**Figure 8.1**

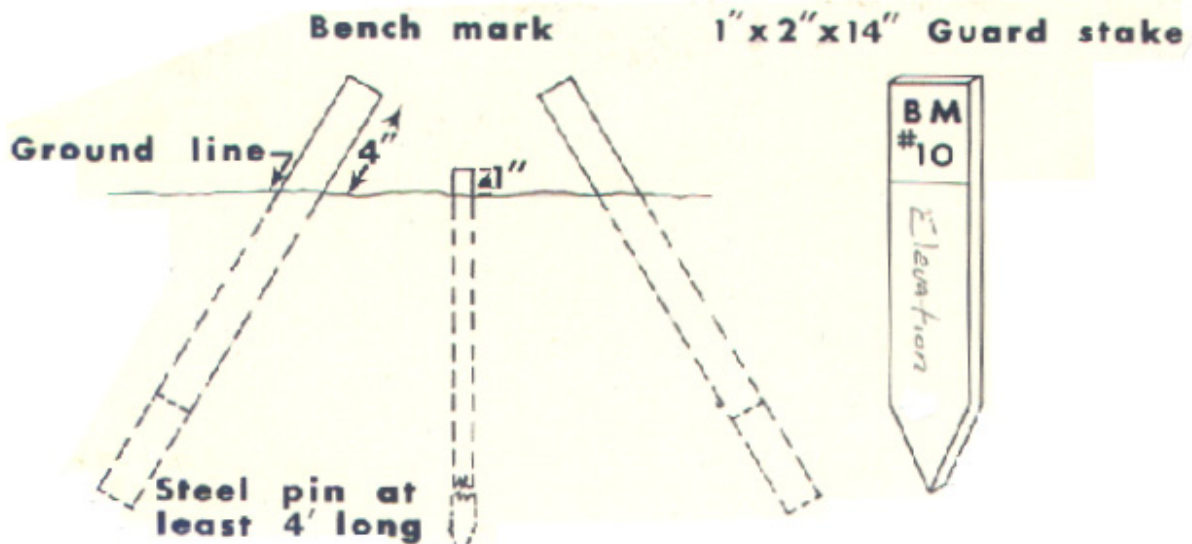

## HUB LINE

Hub Line (grade stakes) are set on both sides of the roadway outside of the work area, normally along the right-of-way or temporary easement lines, so they are not disturbed by the construction activities. These stakes are 2" x 2" x 14" and marked as shown.

The cut (C) or fill (F) is marked on the hub stake indicating the cut or fill to the top of the dirt sub grade at the shoulder of the roadway. This elevation difference is referenced with respect to the original ground directly in front of the hub. The offset on the hub stake is the distance the stake is from the centerline of the roadway.

This is the limits of the highway project and under no circumstance should it be crossed by any machine, without prior written permission of the land owner. Property beyond this line is private property and should be treated as such.

Figure 8.2

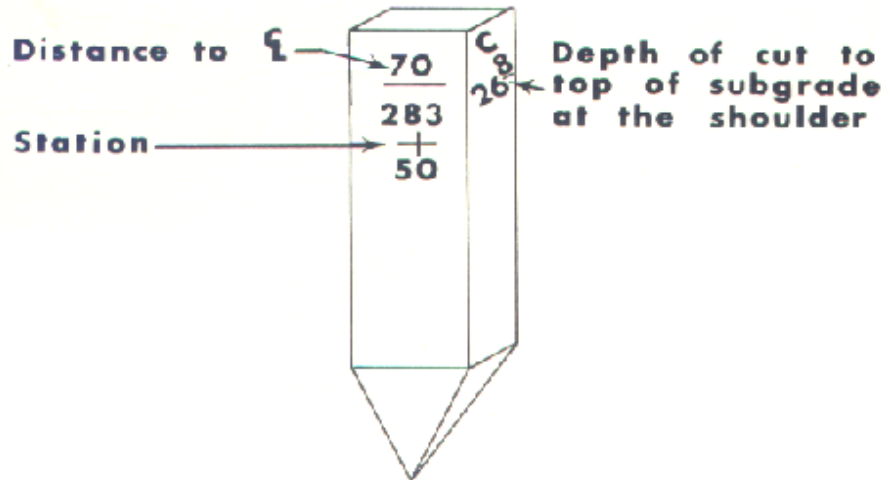

## RIGHT-OF-WAY STAKES

---

Right-of-Way stakes may be set along the project on the right-of-way (R.O.W.) line. This is the property line and limits of the highway project and under no circumstances should it be crossed by any machine, without prior written permission of the owner. Property beyond this line is private property and should be treated as such. This includes you as well as the Contractor.

Shown here is a typical right-of-way stake with the station and distance from centerline on it.

Figure 8.3

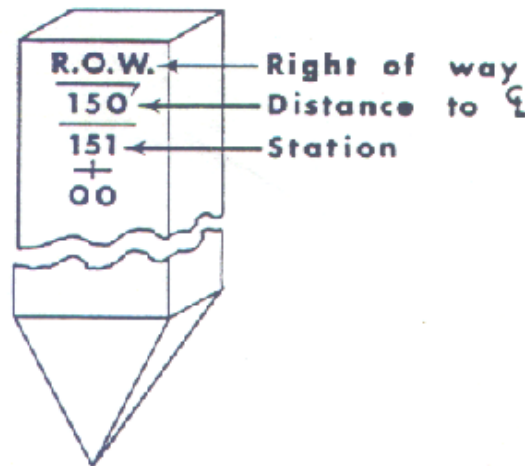

## REFERENCE POINTS

---

Reference points are set by the survey crew and may not necessarily fall on the hub line or centerline. They are set outside the work limits and are used to locate or relocate definite points on centerline, such as:

- Point on Tangent (P.O.T.)
- Point of Intersection (P.I.)
- Point of Curvature (P.C.)

Point of Tangency (P.T.)

And Others.

**Figure 8.4**

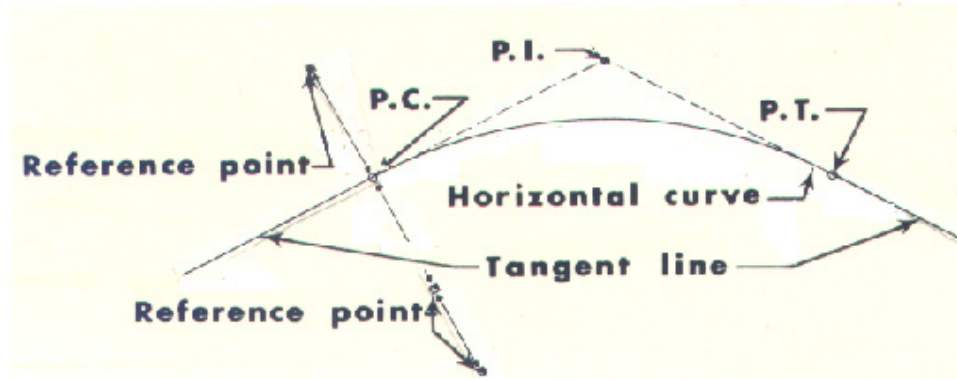

The P.C. is the beginning of the horizontal curve, the P.I. is the intersection of the two tangents of the curve and the P.T. is the end of the horizontal curve.

Reference stakes are placed beside the reference points. These stakes contain information regarding what the point is, station and offset distance.

**Figure 8.5**

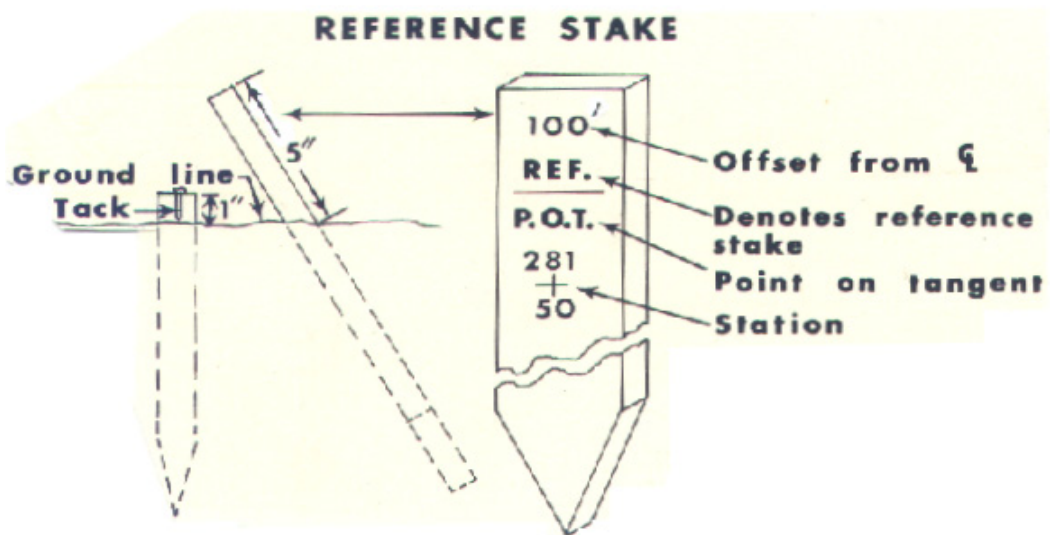

## OFFSET STAKES

Offset stakes are usually used on projects involving old road and where there is the possibility of losing the other stakes due to construction, blasting, etc. They are used to relocate the centerline stationing and any other stakes that might be disturbed. They are placed where they won't be disturbed by the work. The information contained on them is the station and distance from the particular stake being offset. The offset stake is then used to replace disturbed points.

Figure 8.6

## TYPICAL OFFSET STAKE

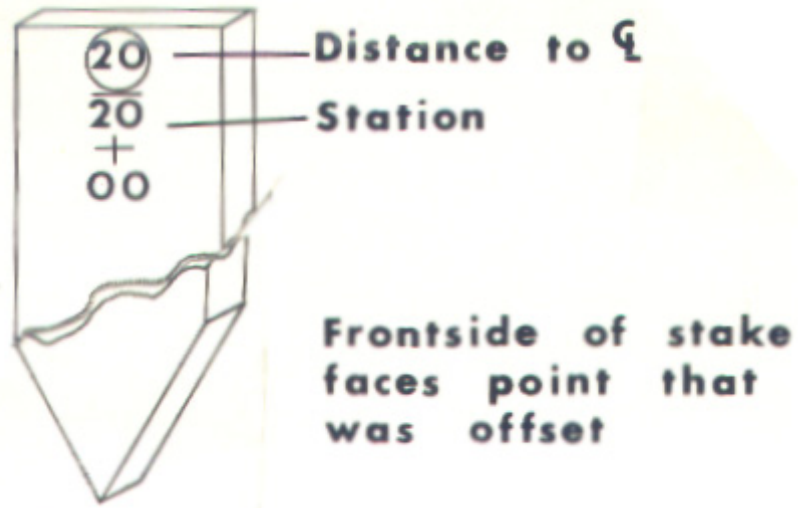

## SLOPE STAKES

Slope stakes are stakes that mark the point where the outer slopes of the cuts or fills meet the original grade or ground.

They are usually set at the same intervals as the cross sections, for example, every 100' or at any plus distance between 100' stations, if needed. They'll be set by the survey crew using information from the typical section and cross section. They provide the first reference point required by work crews because they show the outer limits of the work area. The values for the cut or fill and the distance to the centerline shall be calculated in the field using the procedure discussed in this manual.

Slope stakes show the contractor where the excavation or embankment will intersect the existing ground.

- A cut section slope stake will show where the backslope intersects natural ground.
- A fill section slope stake will show where the inslope catches the existing ground on a fill section.

Figure 8.7

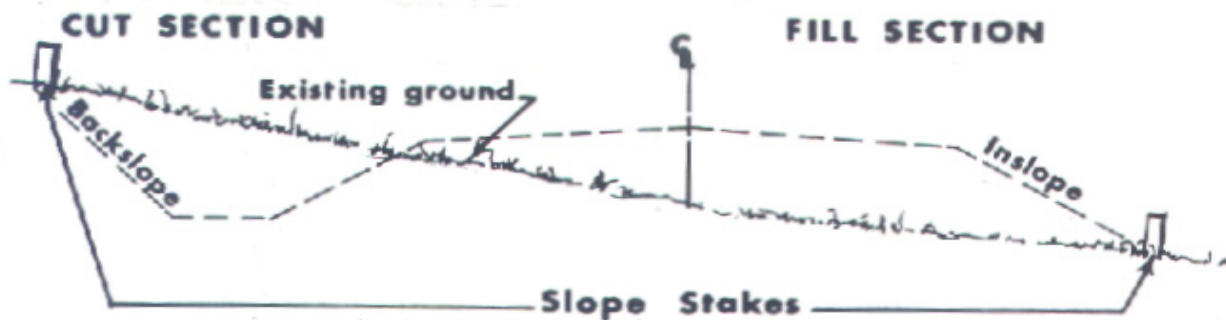

Slope Stakes will be set by survey crew ahead of construction, but it is useful to the inspector to fully understand slope stake markings.

Figure 8.8

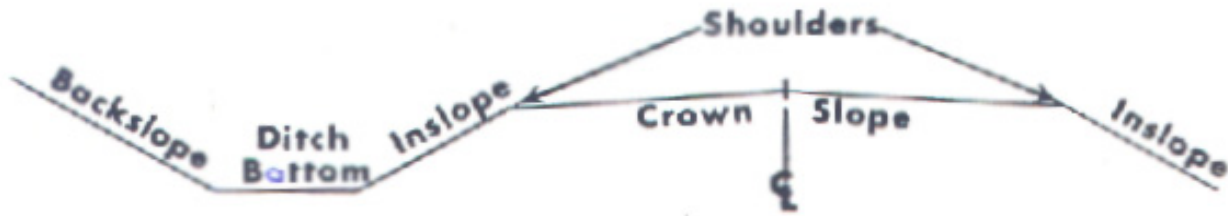

The typical section will show the slopes and distance of each roadway section. The crown slope (roadway top) will be shown in a ratio of feet per feet (ie: 0.02 ft./ft.) which means for each horizontal foot the roadway will slope down 0.02 feet. The rest of the roadway sections (inslopes, ditch bottom and backslopes) will be in a slope ratio (ie: 3:1, 4:1 etc.), in this ratio the first number tells how many feet the slope goes horizontally to a elevation change of 1 foot vertical. A ratio slope of 3:1 means it will take a horizontal distance of 3 feet to change the vertical distance by 1 foot.

Figure 8.9

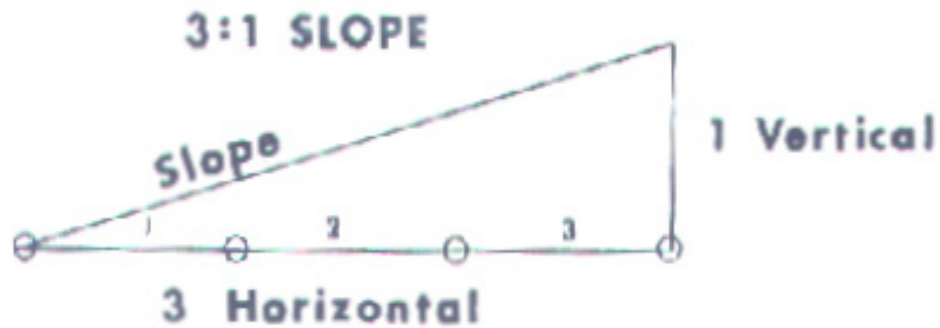

Problem: With the information given below, determine the slope.

Horizontal distance – 30'

Vertical distance – 4'

Slope = \_\_\_\_\_

Following are examples of how the placement of Slope Stake is determined:

<b>C or F</b>	<b>C for Cut F for Fill</b>
<b>AA<sup>A</sup></b>	<b>Amount of Cut or Fill</b>
<b>BB<sup>B</sup></b>	<b>Distance from Centerline to Slope Stake</b>
<b>CC<sup>C</sup></b>	<b>Distance from the Centerline to the point on the typical section where the roadway can be built by using the Typical Section</b>
<b>+</b>	
<b>X:1</b>	<b>Slope ratio of the Cut or Fill</b>

Suppose we are working in a cut section. By looking at the Typical Section (Figure 1), after the Contractor gets to the toe of the backslope, the rest of the roadway can be built by using the slope distance and slope ratio shown for each segment on the typical section.

**Figure 8.10**

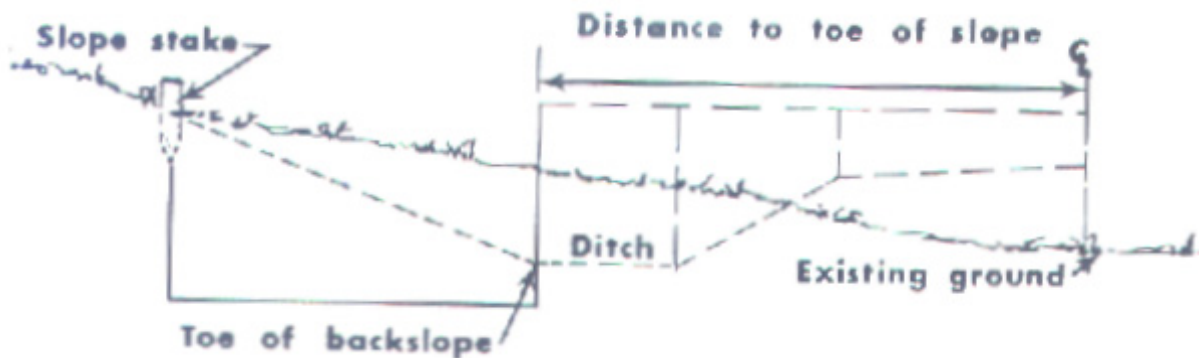

From the typical section, you can figure out how far it is from the centerline to the toe of the backslope by adding the horizontal distances for each of the different roadway segments. This distance is then written on the slope stake above the "+".

The thing that is not known is how far the backslope will go before it intersects the existing ground. The slope stake notes or cross sections can be used to locate the estimated offset where the new backslope will intersect the existing ground. This is called the try distance.

Do the following prior to going into the field to slope stake:

- 1 Calculate the plus distance for the toe of the backslope or top of the inslope from the typical section. By looking at Figure 1, the distance from the centerline to the toe of the backslope (cut section) is 61'. To get that distance add each segment distance,  $12' + 6' + 9' + 14' + 10' + 10' = 61'$ . What is the plus distance for the fill section? \_\_\_\_\_
- 2 Then calculate the elevation difference of the toe of the backslope or top of the inslope from the centerline. By looking at Figure 1, the difference in elevation from

the centerline to the toe of the backslope (cut section) is 4.04'. To calculate that look at each segment of the typical section and calculate how much of a drop is in each segment. The crown slope has  $(12'+6'+9') \times 0.02 = 0.54'$  of fall, the inslope has  $14'/4' = 3.5'$  of fall. The ditch has  $10'/20' = 0.5'$  of fall but also has  $10'/20' = 0.5'$  of rise. So the fall is  $0.54' + 3.5' + 0.5' - 0.5' = 4.04'$  of total fall from the centerline. What is the amount of fall from the centerline to the toe of the inslope in the fill section? \_\_\_\_\_

- 3 By looking at the information above what is the elevation of the toe of the backslope (cut section) and toe of the inslope (fill section), if the centerline elevation is 1233.20? \_\_\_\_\_

Now go to the field, locate the station to slope stake and from the cross section get the elevation of the centerline and scale off to the spot where the new typical section appears to intersect with the existing ground. This spot will be where you do your first try. You know from above that the elevation at the toe of the backslope (cut section) is 4.04' lower than the centerline or 1229.16. By scaling off the cross section for your 1st try, it shows the intersection of the new typical section with the original ground to be 66'. You take a ground shot at that location and have an elevation of 1230.56. Does this spot work for a slope stake?

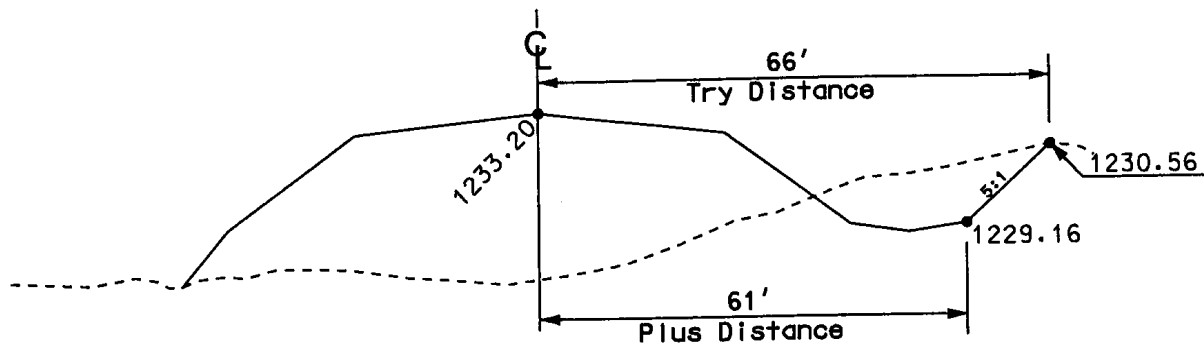

Subtract the toe of the backslope elevation (1229.16) from the existing ground elevation of where you shot (1230.56) to find the amount of cut ( $1230.56 - 1229.16 = 1.4$ ). Take the cut times the slope rate and add it to the distance from the centerline to the toe of the backslope.

Cut x 5:1 (slope rate)

$$1.4' \times 5 = 7.0'$$

$$61' \text{ (plus distance)} + 7' = 68'$$

Since you took a shot at 66' this does not work. Move to a new try location and do the process again.

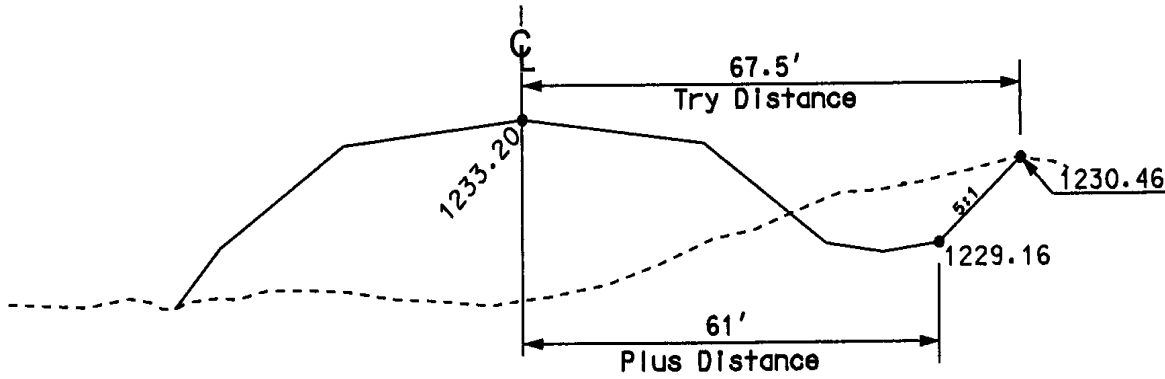

$$1230.46 - 1229.16 = 1.3'$$

$$1.3' \times 5 = 6.5'$$

$$61' \text{ (plus distance)} + 6.5' = 67.5'$$

Since you are at 67.5' this checks out so the slope stake is put in at this point.

The slope stake you would put in at this point should look like this:

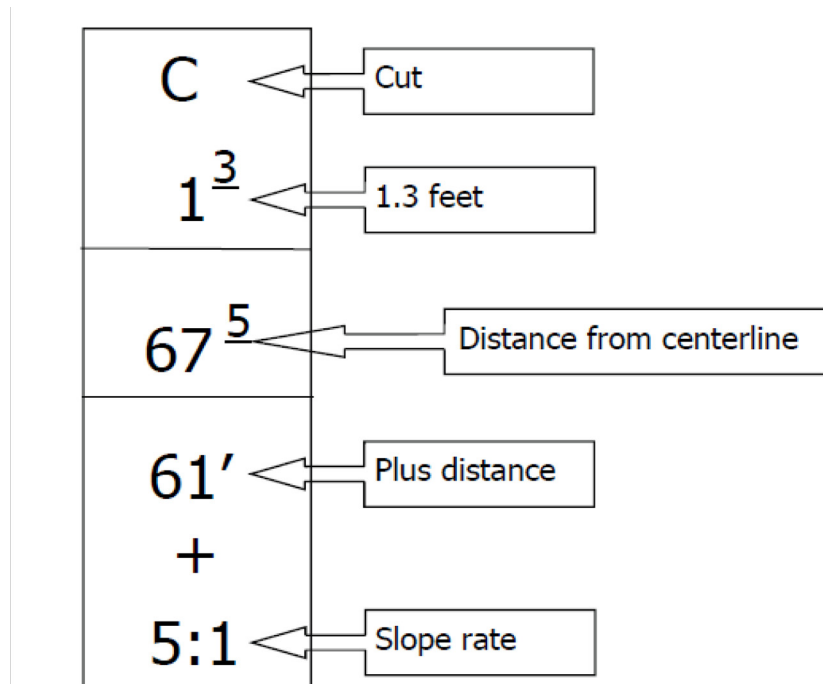



Following is an example of a fill section:

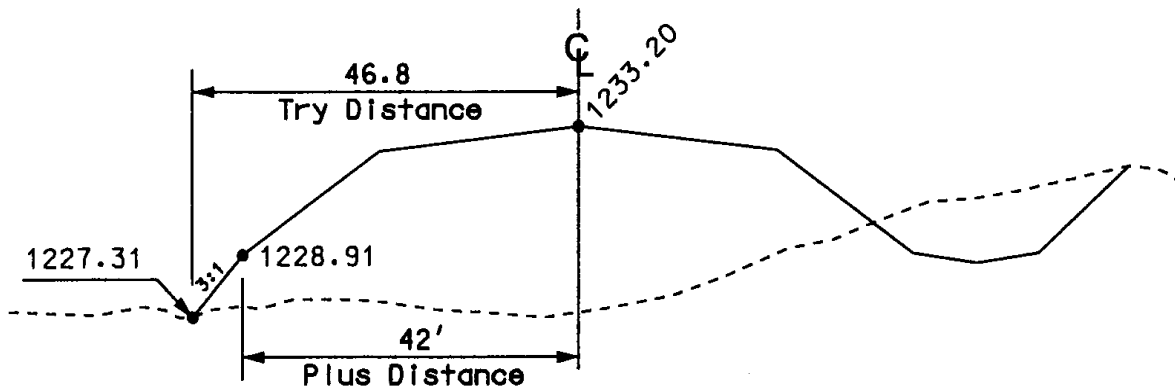

Fill:  $1228.91 - 1227.31 = 1.6'$

$1.6' \times 3 = 4.8'$

$42'$  (plus distance) +  $4.8' = 46.8'$

This checked out since you measured out 46.8'.

The slope stake you would put in at this point should look like this:

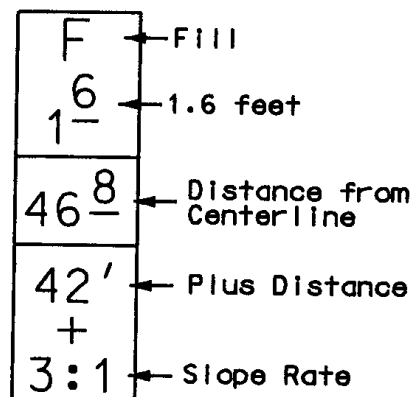

The slope stake is driven in at an angle with the information facing toward the centerline of the road.

To check a slope stake, take the amount of cut or fill times the first number of the slope rate. Then add that number to the plus distance, this should equal the distance the stake is from the centerline.

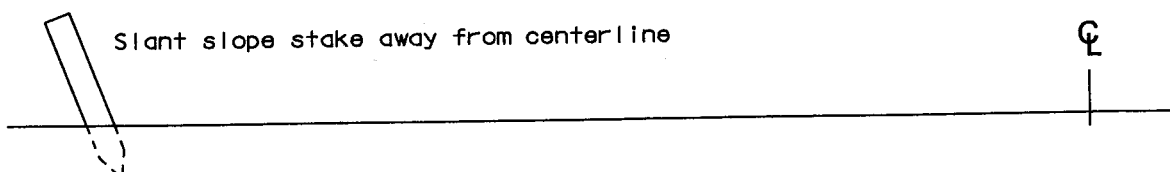

# GRADE AND SLOPE CONTROL

---

During construction the inspector must make sure that the Contractor is constructing roadway sections as specified in the plans. The final riding surface and appearance of the base or surface course depends to a large extent on the condition and uniformity of the sub grade. The base and surface course are necessary to carry the designed traffic loads and provide a smooth riding surface not to level faulty surfaces on the sub grade.

Carefully check the roadway slopes on cut and fill sections to verify that they are being constructed according to the typical sections. Normally, the Contractor will have a grade checker on the project to direct the equipment operators in the construction of the roadway. From the data on the construction stakes set by the survey crew, the Contractor will be able to build the roadway section up to the approximate finished grade. It is his responsibility to build the roadway in accordance with the plans and specifications; however, you should observe these operations closely and inform him of any non-conformity.

The following methods and procedures of checking the grade and slope are only a few that can be used, depending on the personnel available. Any method can be used as long as an accurate end result is achieved.

## Equipment

---

When the inspector is required to check the grade and slopes without the assistance of the survey crew, the following method will normally be used:

- Hand Level
- Cloth Tape
- Leveling Rod

### Hand Level

The Hand Level can be used for control and for work not requiring a high degree of accuracy. It consists of a sighting tube, in the top of which is a small spirit level parallel with the line of sight. A slanted mirror reflects the spirit level so that it is seen vertically beside the field of view. The object glass is marked with a centerline, and may have two or more lines for use in taking stadia readings distance of height. This level is used by holding it to one eye, and tipping up or down until the bubble is centered at the centerline on the glass. Any object cut by this line is then on a level with the observer's eye, and nearby elevations may be determined and levels run.

### Cloth Tape

The cloth tape is used to measure horizontal distance. The tape is usually 100' long and marked in feet and tenths. Tapes with other variations are also available.

**Figure 8.11**

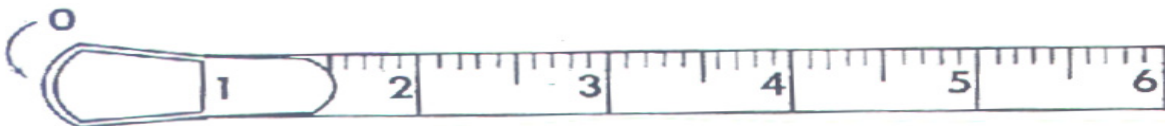

## Leveling Rod

A leveling rod is used to measure the vertical distance. The rod is usually made of wood and the length may be extended from 5' to 15' or more. The rod is marked in feet, tenths, and hundredths.

The slopes of the roadway section must be checked during the rough grading phase of construction to make sure they meet requirements as specified in the plans.

Figure 8.12



Figure 8.13

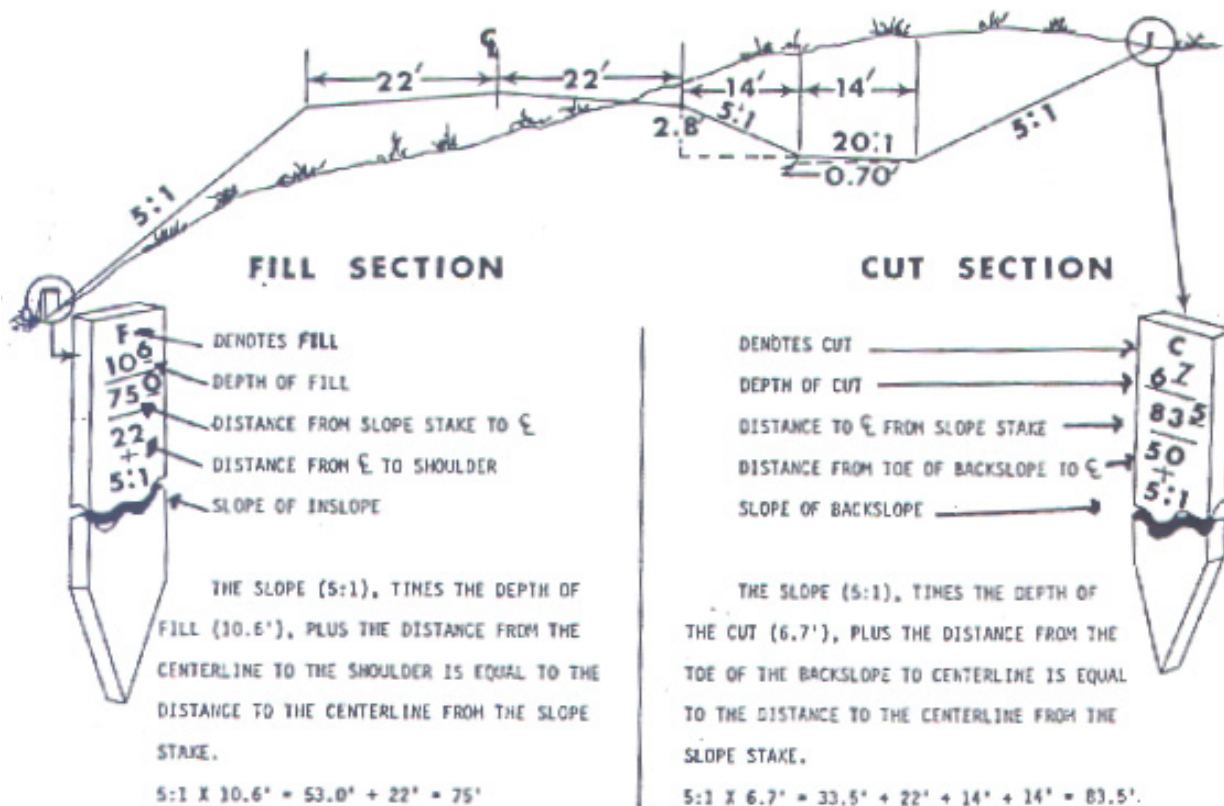

**Figure 8.14**

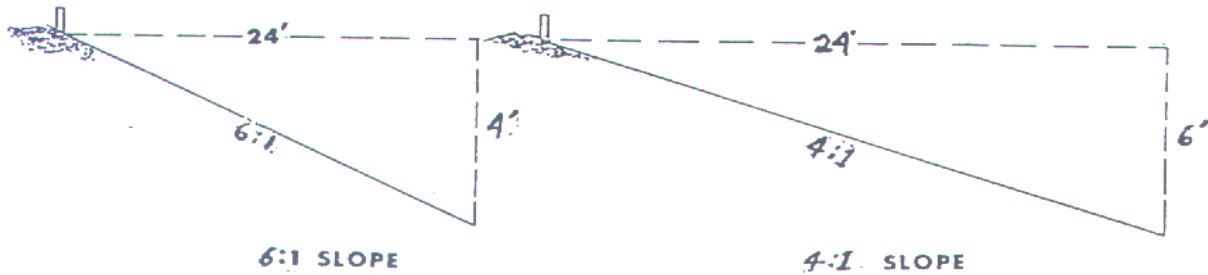

If personnel are not available to assist the inspector, the slope can be checked as follows:

- 1 Locate the slope stake at the top of the cut.
- 2 Determine the rate of slope.
- 3 Measure a horizontal distance from the slope stake equal to a multiple of the specified rate of slope. (For this example, we will use a 3:1 slope. A multiple of 3 would be 9'.) The level rod may be used to measure the distance, or one end of the tape can be fastened to the ground with a nail, etc. and used to measure.
- 4 Place a reference lath in the slope at the point measured 9' – making sure that the lath is vertical.
- 5 Place the hand level against the side of the lath and sight the ground level at the slope stake. Move the hand level up or down to center the bubble in the level, at the base of the stake.
- 6 When the bubble is in the center, do not change the height of the hand level: mark the reference where the centerline of the level crosses it.
- 7 Measure the point marked on the lath to the ground surface at the lath.
- 8 In this example, the vertical distance should be at or near 3'.

**Figure 8.15**

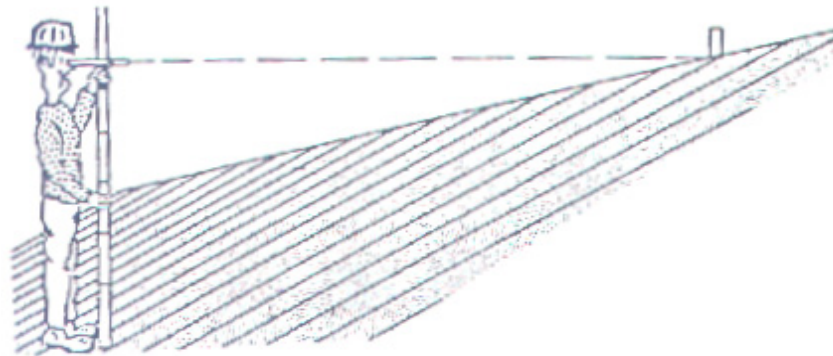

- 9 If the slope is too flat, it will have a vertical distance less than 3'.

**Figure 8.16**

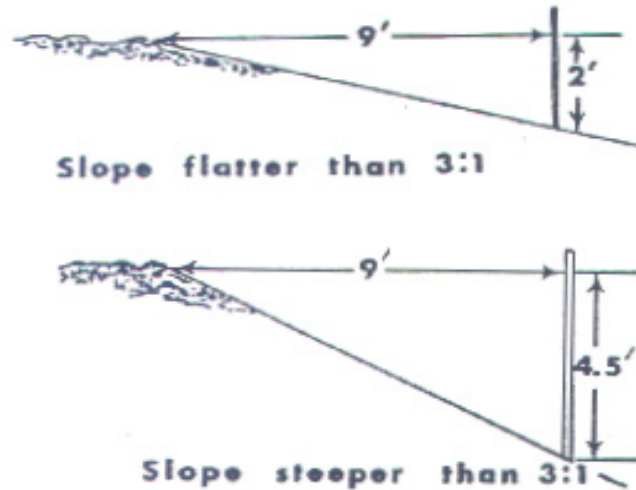

**10** A slope that is too steep will have a vertical distance greater than 3'. Repeat steps 3 through 8, every 9' down the slope until the toe of the slope is reached, except:

- 1** A mark is placed on the first reference lath where the ground slope should have been.
- 2** The vertical measurement marked on the second reference lath is made with respect to this point.

**Figure 8.17**

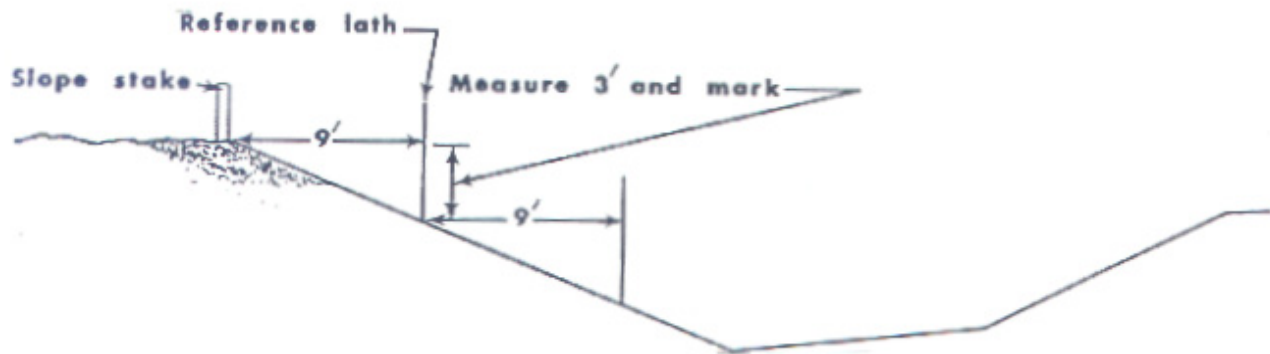

The slope of fill sections can be checked in essentially the same manner as described for cut sections. The inspector can check the slope as follows:

- 1** Locate the slope stake at the bottom of the fills.
- 2** Determine the rate of the slope. (For this example, we will assume the section is to have a 4:1 slope.)
- 3** Set a reference lath beside the slope stake.
- 4** Measure a horizontal distance from the reference lath (Lath A) up the side of the fill – 8' for this example.

Figure 8.18

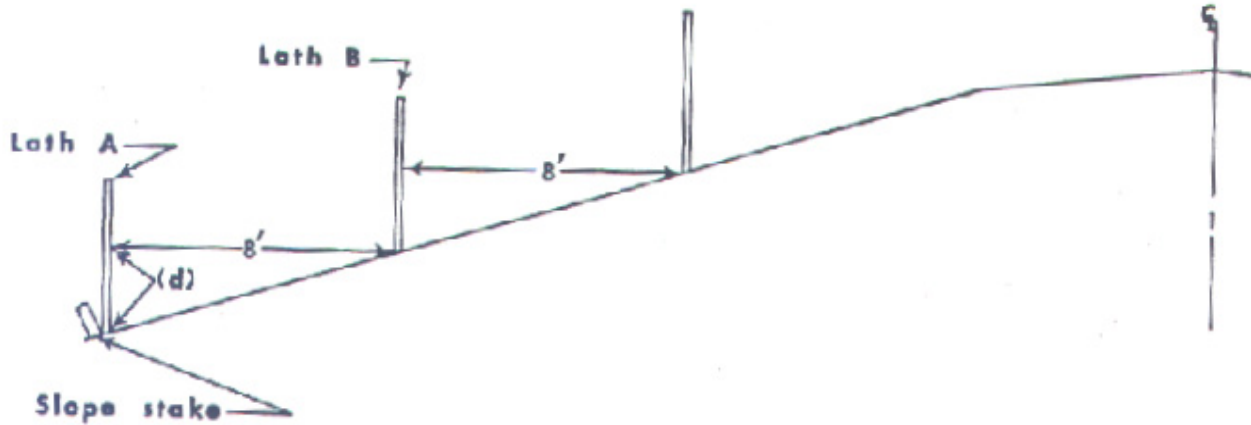

- 5 Set another reference lath at this point (Lath B).
- 6 Place the hand level against the side of lath A and sight the ground level at lath B.
- 7 When the bubble is centered, mark lath A at the point where the level is being held.
- 8 Measure the vertical distance from the mark made on lath A down to the ground surface. (This distance should be 2' for this example.)
- 9 For this example, if the distance to the ground surface at lath A is less than 2', the slope is too flat. If this distance (d) is more than 2', the slope is too steep.

Continue up the slope, setting laths at 8' intervals, and check as explained in the preceding example, until the top of the slope is reached.

Figure 8.19

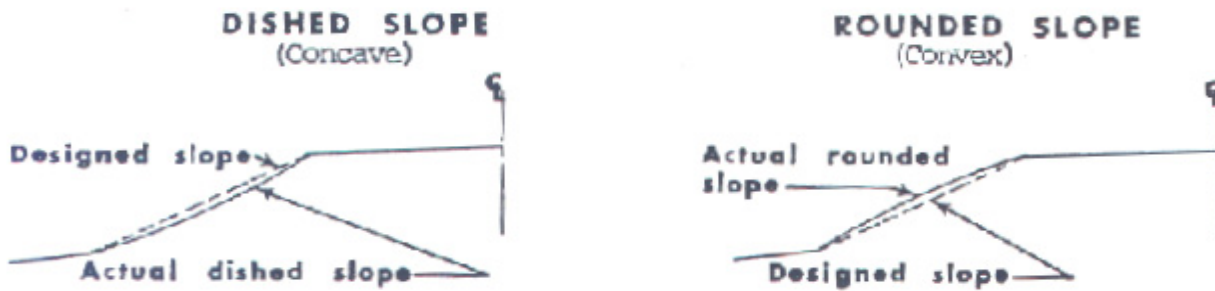

The preceding methods of checking the slope, or other acceptable methods, enable the inspector to spot incorrect slopes before the construction has progressed too far. These checks also enable the inspector to detect dished or rounded slopes. When slopes of this nature are found, the inspector should notify the Project Engineer and Contractor and note the location of such slopes in his diary.

## GRADE CONTROL

Periodically the inspector should check the general alignment of grade by standing in the ditch or along the edge of the roadway. The surface of the roadway should be smooth, not contain any sharp dips or rises. He can also check the general appearance of the shoulder line.

The following methods for checking the grade, or shoulder elevation of the roadway section, can be checked by the inspector where the shoulder is not more than about 5' high. Sections having cuts or fills greater than this will require additional personnel to assist the inspector.

The inspector can use the leveling rod and hand level to check the shoulder on small cuts and fills as follows:

Cut section:

- 1 Locate the hub line stake.
- 2 Measuring from the hub line stake, locate the sub grade shoulder.
- 3 Set a reference lath at this point.
- 4 Use the hand level and sight the top of the hub or the ground in front of the hub, depending on which point is the reference point. Make sure the level bubble is centered.
- 5 Have someone hold a leveling rod beside the reference lath and take a rod reading, or have him mark the coinciding level point on the reference lath.

**Figure 8.20**

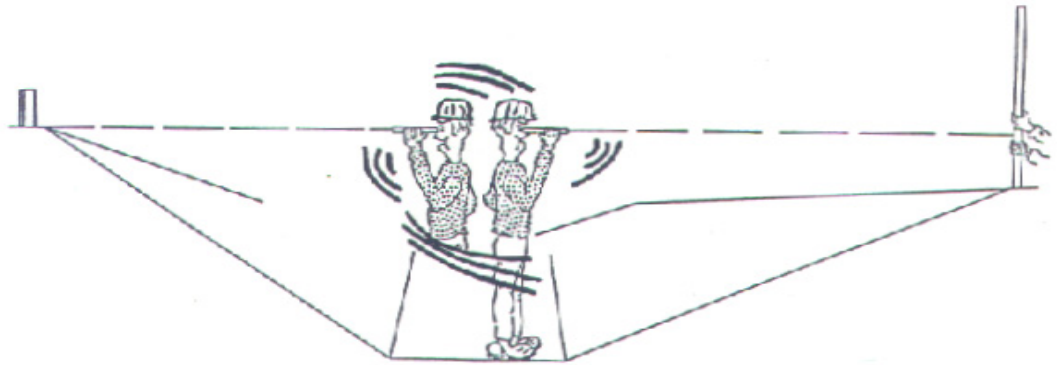

- 6 If the leveling rod is used, compare the rod reading with the required cut or fill marked on the hub stake. If the lath was used, measure the vertical distance down to the ground surface and compare this with the cut marked on the hub.
- 7 If the vertical distance measured on the lath, or the reading on the rod is less than the cut indicated on the hub, the grade is too high and more material must be excavated.
- 8 If this vertical distance is more than the cut indicated on the hub, the grade is too low and material must be placed.

## Fill Section

---

The method of checking a fill section is similar to cut sections except the inspector will either stand by the hub or on the shoulder of the road depending on which is lower. The cut or fill to the shoulder line will be marked on the hub.

**Figure 8.21**

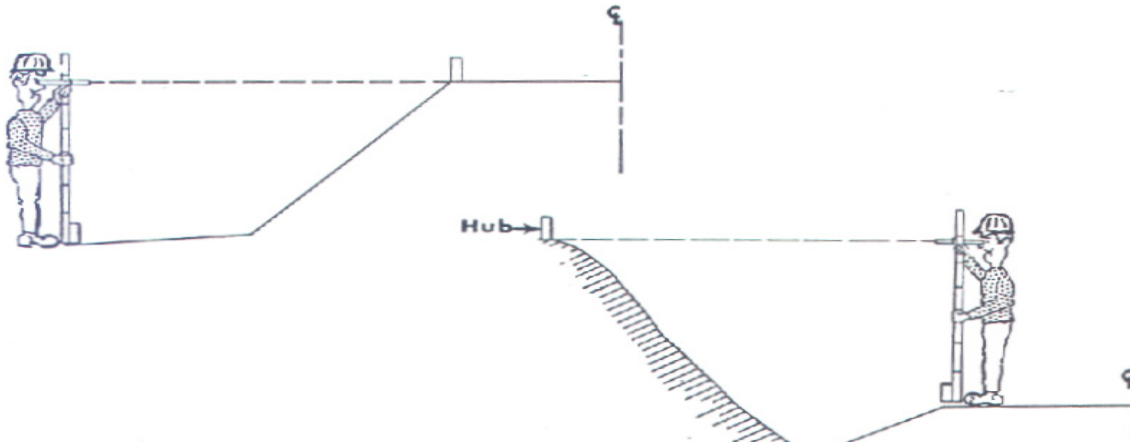

## **BLUE TOPS**

When the sections meet density requirements and are at approximate grade, the Contractor will ask the inspector to notify the survey crew that he is ready for final grading. The survey crew will set the finishing stakes, or blue top stakes (1"x1"x14" or 1"x1"x8"), to establish the correct elevations of the finished sub grade. These stakes normally are set in the sub grade at intervals of 50'(10 m) on normal tangent sections.

In some instances, a nail with a ribbon is used in lieu of wood stakes.

The finishing stakes are set for both line and grade at the centerline and edge of the desired roadway section. On some jobs they may also be at 1/4 points. The stakes are driven down until their tops are at grade. The tops are often colored (with crayon or other markers), to make them more visible. A lath about 1' long is placed beside the bluetop to serve as a guard stake. The Contractor may mark the grade on this lath. The Contractor may also be required to furnish and place this lath.

When the blue tops are set on a portion of the sub grade that is too high, the stakes will be below ground level. On sections that are lower than the proposed finished sub grade, the stakes will be sticking out of the sub grade. After these stakes have been set and are driven to the proper elevation, the Contractor is ready to begin the finishing operations. High points must be shaved off by motor graders and the low areas must be filled in with suitable material. Good blade operations will usually be able to cut or fill the sub grade to the top of the blue top stakes. Excess fill or cut will probably disturb the stakes.

If the motor graders pull out any of the stakes or if the stakes have been obviously run over, it's necessary for the survey crews to reset them. The inspector shall check the final grading operation by observing the tops of the stakes. When the tops of the blue top stakes are at the sub grade surface, the sub grade is at the final or finished elevation.

The Standard Specifications specify the allowable tolerance for the finished elevations.

The sub grade shall be finished to within minus 0.04' to plus 0.08' from the design grade and typical section shown in the plans. The quarter crown within any 12' transverse length shall not exceed 0.08' when measured with a straight edge, stringline or other suitable equipment.

Remember, the closer the sub grade is to the exact desired elevation, the smoother the road will potentially be and fewer problems will be encountered when the surfacing courses are placed.



The plans should be reviewed to make sure that all approaches, ditch blocks, crossovers, etc., are in place and have been constructed according to plans. Continuity of the drainage patterns must also be checked. Drainage can be checked by going over the project after a rainfall has occurred. Any standing water or "duck ponds" will indicate that there is a high or low spot in the ditch grade. These areas must be brought to the attention of the Contractor and fixed. This is usually accomplished by cutting or filling the ditch enough to allow drainage. A motor grader usually is used for this work.

## FIELD TESTING

During the construction of the sub grade, there are field tests that must be performed to insure that the final roadway will be uniform and provide a stable foundation for the base course and surfacing.

All tests must be performed by a certified tester.

The three basic tests involved in earthwork construction are:

- Moisture Tests
- Density Test
- Moisture-Density Tests (commonly referred to as a "Proctor")

### MOISTURE TESTS

---

Moisture tests are performed to determine the amount of water in a given sample of material. The moisture content is expressed as a percent of the material's dry weight. The weight of the water divided by the weight of the dry sample times 100.  $[(\text{wet} - \text{dry})/\text{dry}] \times 100$ . (DOT-35)

When moisture control is specified, frequent tests must be taken until adequate control has been established, then a minimum of one moisture test every two hours shall be taken at each grading construction area. Representative moisture control samples must be taken from the soil immediately under the layer being placed. The sample, if not tested immediately, must be sealed in an airtight container such as a plastic bag. Samples taken in areas where corrective action was necessary should be taken at the same depth, station, and distance from centerline as the failing sample.

#### Standard Moisture Specifications

Specific Density Method: Soil shall be compacted within the moisture specification range in accordance with Table 1, unless otherwise specified. Optimum moisture will be determined in accordance with SD 104 (AASHTO T99). Moisture tests will be determined by SD 108.

**Table 1:**

Optimum Moisture of Embankment Soil	Density Specification (Percent of Maximum Dry Density)	Moisture Specification (Percent of Optimum Moisture)
0% to 15%	95% or Greater	-4% to +4%
15% or Greater	95% or Greater	-4% to +6%

Refer to the Materials Manual to determine when a One-point Proctor will be required.

One method for maintaining a ready reference for the optimum moisture of each soil type and soil mixture would be to place a sample of each soil on which a Proctor is run in a small glass jar. These jars can be referred to when you run your moisture tests. Each time new soils are encountered; new jars should be filled. When you move to a new "fill" area, you may encounter different soils so a new set of samples will be needed.

The following page shows a Moisture Worksheet form (DOT 35).

**Figure 9.1**

**MOISTURE WORKSHEET**

COUNTY \_\_\_\_\_ PROJECT \_\_\_\_\_ PCEMS \_\_\_\_\_ FILE NO. \_\_\_\_\_

TESTED BY \_\_\_\_\_ CHECKED BY \_\_\_\_\_ DATE \_\_\_\_\_

TEST NO.							
SAMPLED AT STATION							
DISTANCE FROM CL							
REPRESENTS STA. - STA.							
DEPTH BELOW GRADE OR TOP OF PIPE							
1-POINT NOT MADE - REFER TO MOISTURE OR DENSITY TEST NO.							

**FIELD MOISTURE**

	TIME						
WT. OF CAN & MATERIAL	METER NO.						
WT. OF CAN & DRY MATERIAL							
WT. LOSS (MOISTURE) / SPEEDY READING	STANDARD MOISTURE COUNT						
WT. OF CAN / WT. OF SPEEDY SAMPLE	PERCENT MOISTURE FROM GAUGE						
WT. OF DRY MATERIAL	MOISTURE CORRECTION (+/-)						
PERCENT MOISTURE	PERCENT MOISTURE						

**1 - POINT DETERMINATIONS**

WT. OF CAN & WET MATERIAL							
WT. OF CAN & DRY MATERIAL							
WT. LOSS/ SPEEDY READING							
WT. OF CAN							
WT. OF DRY MATERIAL							
PERCENT MOISTURE							
WT. OF MOLD & WET SPECIMIN							
PERCENT MOISTURE							
WT. OF MOLD & WET SPECIMEN							
WT. OF MOLD							
WT OF WET SPECIMEN							
FACTOR OF MOLD							
WET DENSITY (LBS.CU.FT.)							
CURVE USED							
MAX. DENSITY FROM I-POINT							
OPTIMUM MOISTURE FROM 1-POINT							

COMMENTS: \_\_\_\_\_  
\_\_\_\_\_

# DENSITY TESTS

---

Density control tests should be taken soon after compaction is completed, normally not to exceed 24 hours thereafter. Density tests should be taken at random stations. Special care is given to areas that show weakness as evidenced by soft spots when equipment passes. When four (4) lane divided highways are constructed, separately, the minimum number of specified test shall apply to each roadbed.

Density tests are performed in the field on material after it has been compacted. The density is expressed in pounds per cubic foot. (DOT-41)

## Moisture-Density Tests

Moisture-Density tests (Proctors) are used to determine the optimum moisture content (the amount of water necessary to compact the soil in the field) and the resulting dry unit weight of material which can be expected from compaction at this optimum water content. (DOT-41) The moisture-density tests (proctors) shows the moisture-density relationship.

It is the responsibility of the inspector to know how to perform the various tests correctly and how to interpret the results once the testing has been accomplished. The tests listed above will, in many cases, be the deciding factor in questions arising about the acceptability of the work performed.

Samples taken and tests made will be in accordance with the most recent South Dakota Department of Transportation Materials Manual – Sampling and Testing Procedures, including revisions or additions which are current on the date of advertisement for bids.

All materials being used in the project are subject to inspection and testing at any time.

## TEST LOCATIONS

Prior to the beginning of grading operations, the minimum number of density tests required should be determined. The project should be split into one half mile "work areas" and the number of zones per work area may then be determined.

Field notes should be prepared prior to construction indicating the zones in each half mile segment. On the following page is an example set of field notes.

The number of zones per work area is determined by reviewing the Cross Sections. Determine the maximum fill by comparing the final grade line with the original grade line.

Refer to Materials Manual - M.S.T.R. 4.1 SPECIFIED DENSITY (IN PLACE)

**Table 2:**

Depth from top of sub grade	Rate of field testing of each half mile
0-1 foot	1 per zone
1-3 feet	1 per zone
3-5 feet	1 per zone
5 feet to base	1 for each 5' of material of embankment

**EXAMPLE FIELD NOTES**

<i>349+36 to 322+96</i>	<i>Test</i>	<i>Density</i>
<i>Zone 0-1'</i>	<i>32</i>	<i>97%</i>
	<i>41</i>	<i>97%</i>
<i>1'-3'</i>	<i>28 28X</i>	<i>94% 96%</i>
	<i>30</i>	<i>99%</i>
<i>3'-5'</i>	<i>31</i>	<i>98%</i>
<i>322+96 to 296+56</i>		
<i>Zone 0-1'</i>	<i>36</i>	<i>98%</i>
<i>1'-3'</i>	<i>33</i>	<i>96%</i>
	<i>34</i>	<i>101%</i>
<i>3'-5'</i>	<i>37 37X</i>	<i>94% 97%</i>
<i>5'-10'</i>	<i>27</i>	<i>95%</i>
<i>10'-15'</i>	<i>23</i>	<i>98%</i>

In determining the actual moisture and/or density test location avoid tire ruts from passing traffic, and areas where rollers turned around while compaction was preceding, if the rollers turned around for each pass in about the same spot. If turn around progressed down the roadway during the course of the work, this latter requirement can be ignored. The inspector must select the test holes in a completely random manner. Do not adopt any procedure such as center line, then right roadway, then left roadway. The inspector should also avoid taking tests in a regular pattern as to the length of the roadway. If the first test was taken at Station 120+00, the inspector should not take each succeeding lift test at the same location. Mix up the pattern as to station and as to the center or either side of the road.

When selecting a representative test site in the area to be tested, the following should be recorded on the DOT-41 or DOT-35.

- Station where the test will be taken
- Distance left or right of the project centerline

- Depth below finished sub grade

A representative test site is one that will provide an approximate average of all the material within an area. Additional tests should also be run on areas that look improper to determine if the area meets specifications. If an area does not meet Specifications, corrections must be made and the area re-tested.

The procedures for performing the various basic tests are given in the South Dakota Materials Manual. The use of each test and the job control requirements are explained here.

## Standard Density Specifications

---

Standard Specifications state that earth embankment must be compacted to 95% of maximum dry density unless otherwise specified. Some exceptions to this are:

- All roadway embankments within the area bounded by the toe of the berm slope and extending to a line 100' from the bridge end shall be compacted to 97% of maximum dry density.
- Field and farm entrances, ditch and channel blocks and dikes shall be constructed and compacted as directed by the Engineer.
- Embankment containing over 40% durable material passing an 8" square opening and retained on a  $\frac{3}{4}$ " sieve and causing unreliable in-place test results shall be compacted with a sheepsfoot or other satisfactory rollers. Durable material is material that will not break down to 100% passing the  $\frac{3}{4}$ " sieve after being soaked in water for 24 hours.
- Specified Density requirements are waived for A-3 soil (fine sand) or A-2-4(0) soil consisting primarily of fine one grain size sandy material. Embankment composed of these materials shall be constructed in layers not exceeding 8" loose depth at the moisture content specified by the engineer. Vibratory rollers or pneumatic tired rollers approved by the engineer will be used for compaction.
- When A-1 soil (gravelly) is encountered, density requirements shall be adhered to, however, moisture requirements shall be as specified by the Engineer.
- If Ordinary Compaction Method is specified, compaction may be accomplished with any type equipment, which, with adequate moisture content, will produce uniform satisfactory results. Sufficient density tests are taken to ensure that the required density is being obtained with the equipment and procedure being used. Once the procedure has been established, additional density testing will be performed at the direction of the Project Engineer.

Prior to placement of granular surfacing materials, the upper 6" of sub grade shall be reworked and recompacted to moisture and density requirements. This is not required for A-3 and A-2-4(0) soils.

Notes:

- *Over 40% Durable (Rock) Material.* Document the 40% rock (greater than  $\frac{3}{4}$ " material) on a DOT-41. Number as if it were a normal density test.
- *A-3 and A-2-4(0) Material.* The density test is waived but a Soil Classification Test SD 103 is required to determine soil type. Number the Sieve Analysis as if it were a Density Test.
- After securing test samples, the inspector should refill all test holes with acceptable material and recompact it by tamping with a shovel handle or similar tool.

- Never manipulate tests to obtain the desired results. If a test, taken according to established procedures, fails to meet specifications, the material tested must be recorded as failing. If the test passes, the results must be recorded as such. Most Contractors want to know the test results as they can use this information to better distribute personnel and equipment, which will result in an improved and more profitable job.
- If the inspector feels the work being accomplished or material being produced is sub-standard, even when passing test results are obtained, he should communicate his suspicions with reasons to the Project Engineer.

The following page shows a Density Report (DOT 41).



COUNTY \_\_\_\_\_ PROJECT \_\_\_\_\_ PCEMS \_\_\_\_\_ FILE NO. \_\_\_\_\_  
 STATION \_\_\_\_\_ DIST. FROM CL \_\_\_\_\_ RT or LT \_\_\_\_\_ WIDTH (Gravel) \_\_\_\_\_

DEPTH \_\_\_\_\_ (from top of Subgrade or Pipe) (Hole - Gravel) TEST NO. \_\_\_\_\_  
 TESTED BY \_\_\_\_\_ CHECKED BY \_\_\_\_\_ DATE \_\_\_\_\_  
 (EMBANKMENT) (BERM) (PIPE)  
 (BASE COURSE) (SUBBASE)

**WORK AREA REPRESENTED** (Circle what applies)

**EMBANKMENT** STA. TO ST/ \_\_\_\_\_ (per half mile/800 m, for each roadbed)

Zone 1(0-1ft./0-300mm), Zone 2(1-3 ft./300-900mm), Zone 3(3-5 ft./900-1500mm), Zone 4(5 ft./1500mm to base, 1 per 5 ft./1500mm)

**BERM** STA. TO ST/ \_\_\_\_\_ (100 ft./30 m from Bridge End)

Zone 1(0-1ft./0-300mm), Zone 2(1-3 ft./300-900mm), Zone 3(3-5 ft./900-1500mm), Zone 4(5 ft./1500mm to base, 1 per 5 ft./1500mm)

CROSS 24"/600mm or Smaller (undercut) (1/2 way up) (2'/600mm Above)

**PIPE** STORM 30"/750mm to 72"/1800mm (undercut) (Lower 1/2) (Upper 1/2) (2'/600mm Above)

INTERSECTION 72"/1800mm or More (undercut) (Bottom 1/3) (Middle 1/3) (Top 1/3) (2'/600mm Above)

After Minimum for size pipe installation ( ) 1 per 3 ft./900mm of backfill beginning at 2'/600mm above top of pipe

**SUBBASE** STA. TO ST/ \_\_\_\_\_ LIFT \_\_\_\_\_ (per mile / 1600 m, per roadbed)

**BASE COURSE** STA. TO ST/ \_\_\_\_\_ LIFT \_\_\_\_\_ (per mile / 1600 m, per roadbed)

CURVE USED	1-POINT MAXIMUM DENSITY	OPTIMUM MOISTURE %	GRANULAR MATERIAL		SPECIFICATION	%
			4-POINT RANGE	% OBTAINED		%
U. _____	_____	_____ %	_____ TO _____	_____	_____	_____ %

BALLOON METHOD		SAND METHOD		NUCLEAR METHOD	
B. WT. UNDRIED MATL. FROM HOLE	_____	A. STD. SAND PCF OR kg/m <sup>3</sup>	_____	GAUGE NO. _____	DEPTH _____
C. VOLUMETER READING IN HOLE	_____	B. WT. UNDRIED MATL. FROM HOLE	_____	TEST MODE _____	
D. INITIAL VOLUMETER READING	_____	C. INITIAL WT. SAND	_____	A. STANDARD COUNT	_____
E. VOLUME OF TEST HOLE (C - D) [ x 0.028317 METRIC ]	_____	D. FINAL WT. SAND PLUS CONE SAND	_____	B. WET DENSITY FROM GAUGE ± CORR. * _____ = _____	
F. WET DENSITY (B / E) [ / 1000 METRIC ]	_____	E. VOLUME OF TEST HOLE (C - D) / A [ / 1000 FOR METRIC ]	_____	C. DRY DENSITY (from Gauge) _____	
G. DRY DENSITY F / ( 100 + M ) x 100	_____	F. WET DENSITY ( B / E ) [ / 1000 METRIC ]	_____	or B/(100 + E-FIELD) x 100	
		G. DRY DENSITY F / ( 100 + M ) x 100	_____	or B/(100 + M-FIELD) x 100	
				(Circle Method Used)	

STANDARD DENSITY DETERMINATIONS (1-POINT)		MOISTURE DETERMINATIONS	
	1 - POINT	FIELD	NUCLEAR METHOD FIELD
O. WEIGHT OF MOLD & SPECIMEN	_____	H. WT. OF WET MATL. AND CONTAINER	D. STANDARD MOIST. COUNT _____
P. WEIGHT OF MOLD	_____	I. WT. OF DRY MATL. AND CONTAINER	E. PERCENT MOISTURE from Gauge _____
Q. WET WEIGHT OF MOLDED MOLDED SPECIMEN ( O - P )	_____	J. WT. OF MOISTURE ( H - I )	± CORR. * _____ = _____
R. FACTOR OF MOLD No. USED IN TEST	_____	K. WT. OF CONTAINER	
S. WET DENSITY ( Q x R ) [ \ 1000 FOR METRIC ]	_____	L. WT. OF DRY MATL. ( I - K )	
T. DRY DENSITY S / ( 100 + M [ 1-PT ] ) x 100	_____	M. PERCENT MOISTURE FIELD ( J x 100 ) / L	

\* CORRECTION FROM DOT-39. IF THERE IS NO CORRECTION OR, IF THE CORRECTION HAS BEEN APPLIED TO THE METER SHOW "NA".  
 1-POINT NOT MADE THIS TEST, REFER TO MOISTURE TEST NO. \_\_\_\_\_ or DENSITY TEST NO. \_\_\_\_\_

COMMENTS: \_\_\_\_\_  
 \_\_\_\_\_  
 \_\_\_\_\_

DETERMINATION OF CORRECTION FACTORS

**NUCLEAR DENSITY AND MOISTURE**

COUNTY \_\_\_\_\_ PROJECT \_\_\_\_\_ PCEMS \_\_\_\_\_

NUCLEAR GAUGE NUMBER \_\_\_\_\_ TESTED BY \_\_\_\_\_

DATE \_\_\_\_\_ CHECKED BY \_\_\_\_\_

		Moisture (percent)	
		Oven Dry	Nuclear Gauge
1			
2			
3			
4			
5			
Total Average		(A)	(B)

		Wet Density (lbs./cu. ft.)	
		Sand or Balloon Test	Nuclear Gauge
1			
2			
3			
4			
5			
Total Average		(C)	(D)

Moisture Correction

Compare A & B: Difference = \_\_\_\_\_. If the difference between A & B is less than 1.0%, it can be disregarded and no correction will be made on succeeding tests.

If A is more than 1.0% greater than B, the difference will be added to the gauge moisture content on succeeding tests.

If B is more than 1.0% greater than A, the difference will be subtracted from the gauge moisture content on succeeding tests.

Correction ±: \_\_\_\_\_

Wet Density Correction

Compare C & D: Difference = \_\_\_\_\_. If the difference between C & D is less than 1.0 lbs./cu. ft., it can be disregarded and no correction will be made on succeeding tests.

If C is more than 1.0 lbs./cu. ft. greater than D, the difference will be added to the gauge wet density on succeeding tests.

If D is more than 1.0 lbs./cu. ft. greater than C, the difference will be subtracted from the gauge wet density on succeeding tests.

Correction ±: \_\_\_\_\_

Comments: \_\_\_\_\_  
 \_\_\_\_\_  
 \_\_\_\_\_

cc: Region Materials Engineer

# 10

## DRAINAGE

The road is designed for maximum stability under the existing conditions for each project. It was emphasized during the inspection of the excavation and embankment operations that moisture control is very important. Surface and subsurface drainage is also very important to maintain a stable subgrade. Many soils offer satisfactory support when relatively dry, but will soften or deform if exposed to excess water. Therefore, provisions are made during design and construction operations for:

- Surface Drainage
- Subsurface Drainage

**Surface Drainage** is accomplished by building a crown in the road and sloping the shoulders to side ditches or gutters. Surface runoff from adjacent land may also be gathered in these ditches. In high cuts, small intercepting ditches are often provided at the top of the slope to catch the surface flow and to prevent excessive erosion of the cut slope face. These ditches are led into natural water runs or into paved channels that run down the face of the cut. On most fills a 20 to 1 slope is built along the edge of the fill to keep surface flow away from the toe of the embankment. On high fills, paved channels or downspouts, etc., are usually provided to carry the water down the embankment. This helps to eliminate or keep erosion to a minimum.

Side ditches drain into natural stream crossings or into pipes that will carry the water to the lower slopes. Culverts are provided for cross drainage at low points in the ground profile.

In "town sections," paved gutters are provided at the outer edges of the pavement. These usually drain into catch basins with pipe outlets or into a storm sewer system. Sidewalks are sloped from the property line to the curb, in order to drain the water into the gutter.

**Subsurface drainage** is needed where the ground water level is near the ground surface or is expected to move up close to the ground surface. In these locations, drains are constructed under the shoulders to lower the ground water level and to keep moisture from reaching the upper portions of the subgrade. If water is allowed to reach these areas, it may cause a failure in the roadway surface.

The importance of the slopes, ditches, etc., being built according to plan cannot be over-emphasized. Unless otherwise noted on the computerized slope stake notes, the constructed slopes and ditches between work limits should be exactly as that shown on the plans. All variations of slopes, ditches, etc., which don't concur with the plans or the slope stake notes must be noted.

## FENCING

### REMOVAL OF EXISTING FENCE

---

One of the first things that a Contractor will do on a project is to remove existing fence. In most instances the Landowner has the right to remove the fence himself and keep it. If the Contractor removes the fence it becomes his property for disposal.

Contact the landowners prior to fence removal to give him an opportunity to remove the fence. There are other items that should be reviewed with the landowner:

Discuss if the landowner has cattle in the field adjacent to where fence is to be removed, a temporary fence may need to be installed. The new fence may be installed if grading operations, including topsoil piles, will not disturb the fence.

If temporary fence is required there are two major types used on the project.

1. Type 1: this temporary fence shall be removed by the Contractor at the completion of the project. Upon installation of the Type 1 Temporary Fence the Contractor shall be paid 90 percent of the contract cost. Upon removal of the fence at the end of the project the remaining 10 percent of the contract cost shall be paid.
2. Type 1A: This temporary fence shall remain in place after the completion of the project and will become the property of the landowner. The Contractor will be paid for 100 percent of the cost of the Type 1A Temporary Fence when the fence is installed on the project.

Discuss the location of the fence as shown on the plans and make sure this is where the landowner wants the fence. Some landowners want the fence placed along the ROW regardless of if the fence would be on a flat area or on the backslope. Other landowners prefer to have their fence follow the temporary easement line. The landowner should have spoken to a right-of-way agent regarding this, but they will often change their mind.

The Project Engineer should have a copy of the ROW Agreements and discuss with landowner type of fence and the location of approaches and other items that may affect the landowner.

### PLACEMENT OF RIGHT-OF-WAY-FENCE

---

Refer to Plans, specifications and Standard Plates for information regarding placement of right-of-way Fence. When placing Right-Of-Way Fence on all routes

except for the Interstates, the fence shall be placed on the outside of the right-of-way, this fence shall become the property of the Landowner. On Interstates, the Right-Of-Way Fence shall be placed 1' inside of the right-of-way, this fence remains the property of the State and the State is required to maintain it in order to maintain Control of Access.

**Figure 11.1**



# 12

## FIELD LABORATORY

The plans will specify the type of field laboratory the Contractor must furnish. See Section 600 of the Standard Specifications for the specific requirements for field laboratories. The Contractor and Project Engineer will select the location of the field laboratory.

An initial inspection of the field laboratory should be performed immediately after the lab has been set on the project and Form DOT-50 needs to be completed.

**Figure 12.1**

File No. \_\_\_\_\_

**FIELD LABORATORY INSPECTION RECORD**

Project \_\_\_\_\_ County \_\_\_\_\_ Contractor \_\_\_\_\_

This record is provided to determine compliance with specifications, to document acceptable deviations, and to record the initial and final condition of the contract Field Laboratory used on this project.

**NOTE:** Representatives of the South Dakota Department of Transportation and the Contractor should make the initial inspection and record when the Field Laboratory is placed, ready for use, and the final report when the project is completed or the Laboratory released. Minor deviations which do not impair its usefulness, or are compensated for by related features exceeding minimum specification requirements, will be permitted when explained and documented herein. Changes made in locations of, malfunctions, damages, and/or repairs made to the Field Laboratory shall be recorded. Briefly describe, in column 9, or the summary, all notations made in columns 4, 6, and 8.

ITEM  (1)	Quantity or Dimensions (2)	SPECIFICATION COMPLIANCE		CONDITION OF LABORATORY				INSTRUCTIONS: Use numerical values, Col. 2. Indicate by "yes" or "no", Col. 3 & 4. Check ( ) proper column, Col. 5, 6, 7, 8.  REMARKS  (9)
		Satisfactory (3)	Accepted as Noted (4)	Begin Proj.		End Proj.		
				Satisfactory (5)	Needs Repair (6)	Satisfactory (7)	Needs Repair (8)	
1. AIR CONDITIONER								
2. CABINET (enclosed)								
3. CHAIRS								
4. DESK (movable)								
5. DIMENSIONS (interior)	Length _____ Width _____ Height _____							
6. DOORS								
7. EQUIPMENT (for concrete test specimens, if req'd)								
8. EXHAUST FANS								
9. FUEL								
10. LIGHTS (electric)								
11. OUTLETS (electrical)								
12. POWER								

(1)	(2)	(3)	(4)	(5)	(6)	(7)	(8)	(9)
13. RANGE Size _____ Burners _____ Fuel _____								
14. ROOMS OR SECTIONS								
15. SINK								
16. STOOLS								
17. TABLES (attached)								
18. TABLES (movable)								
19. WATER SYSTEM Capacity _____ Pressure _____ Gravity _____								
20. WINDOWS								
21. FIRE EXTINGUISHERS								

SUMMARY AND ADDITIONAL COMMENTS:

---



---

DEPARTMENT OF TRANSPORTATION

CONTRACTOR

Initial Inspection \_\_\_\_\_  
 Name Title Date Name Title  
 Date

Final Inspection \_\_\_\_\_  
 Name Title Date Name Title  
 Date

ACCEPTED FOR FINAL PAYMENT \_\_\_\_\_  
 Name Date  
 \_\_\_\_\_  
 Title



**GLOSSARY OF TERMS**

**ADDITIONAL EXCAVATION:** The extension or widening of the normal excavation area (proposed or provided on plans).

**BACKFILLING:** Process of replacing previously removed soil materials from under cut areas.

**BASE COURSE:** Material placed between subbase and surfacing materials.

**BENCH INTO:** A procedure for placing an embankment against a slope greater than four to one (4:1).

**BENCHMARK STAKES:** A stake marking an established point of known elevation, which is used to determine the elevation of other points.

**BENTONITE:** Either of two principally aluminum silicate clays, containing some magnesium and iron, distinguished by sodium or calcium content with corresponding high or low swelling capacity, and used in various adhesives, cements, and ceramic fillers. Named after Ft. Benton, Montana.

**BERM:** a. narrow ledge or shelf, as along a slope. b. shoulder of a road. c. ledge between a parapet and the moat in a fortification.

**BLASTING:** The breaking up of rock through use of explosives.

**BORROW:** Material used that is brought in from areas outside the roadway construction zone.

**CENTERLINE STAKES:** Stakes set on the centerline of alignment of the roadway.

**CLEARING-GRUBBING:** Removal of surface clutter from the intended roadbed and right of way including vegetation and structures.

**COMPACTION:** The compression of soil particles, which result in a higher soil density (increased weight per volume).

**CONSTRUCTION STAKES:** Stakes placed by a survey crew to assist the contractor to perform his work and to assist the inspector in measuring the contractor's performance.

**CROSS SECTION:** The data illustrating profiles taken at right angles. (A representative sample meant to be typical of the whole.)

**CUBIC YARD:** Part of the system of unit measurement used to measure volume or capacity. It is a volume of a cube having three measurements: length, width, and thickness (depth). e.g. A truck box 9' long, 6' wide, and 3' high equals how many

cubic yards?  $9 \text{ times } 6 = 54 \text{ times; } 3 = 162$ . 162 divided by 27 (number of cubic feet in 1 cubic yard) equals 6 cubic yards.

**CUTS:** An area where material is "cut out" or excavated and moved to a new location.

**DAILY DIARY:** A required recording of information and activity that takes place during each shift or day of an Inspector.

**DENSITY TEST:** A field test performed on material after compaction and expressed in pounds per cubic foot.

**DISHED SLOPE:** A sloped area that is concave in appearance and needs additional material to bring it to proper design.

**EMBANKMENT:** (called "fill") is the material placed between the original ground surface and the subgrade. This material is obtained from the excavation areas and may be anything from soil or sand to broken up boulders.

**EXCAVATION:** is the process of cutting or digging material out of a certain area. These areas are called "cuts" because the material is "cut out" and moved to a new location.

**FINAL GRADE:** That point in construction where the roadbed has been constructed to a point where it is ready to receive pavement structure.

**FINAL GRADE STAKES (BLUE TOPS):** Stakes that are set for both line and grade at centerline and the edge of the desired roadway section to show the top of the grade. The tops are usually colored with a crayon or marker.

**FORCE ACCOUNT:** An accounting for work conducted by the contractor that is outside of, or in addition to, what is covered by the contract.

**GRADE STAKES:** (See HUB LINE)

**HORIZONTAL ALIGNMENT:** The route of a road as it would appear on a map showing curve and straight sections of the roadway.

**HUB LINE:** Grade stakes that are set on both sides of the roadway outside the work area (along an easement or right of way).

**MOISTURE TESTS:** A test performed to determine the amount of water in a given sample of material expressed as a percent of the material's dry weight.

**NON-SALVAGEABLE MATERIAL:** Material that cannot be reused and must be broken up or reduced so that it can be satisfactorily disposed of.

**OFFSET STAKES:** Stakes placed in areas where they will not be disturbed by construction activity and used to relocate centerline stationing or any other stake that might be disturbed.

**OPTIMUM MOISTURE CONTENT (OMC):** The definite moisture content of which a soil will compact most readily to its highest density (weight per volume).

**ORDINARY COMPACTION:** Obtaining uniform compaction through any type of equipment to achieve satisfactory results.

**SUBGRADE:** is the top surface of a roadbed upon which the pavement structure and shoulders are constructed.

**PAVEMENT STRUCTURE:** The combination of subbase, base course, and surface course placed on a subgrade to support and distribute traffic load.

**PRE-CONSTRUCTION MEETING:** A formal meeting prior to the commencement of construction activities during which start dates, schedule of operations, special methods, and equipment, safety programs, and other matters are discussed and clarified.

**PRE-SHEARING:** A method used to establish a smooth face when rock is blasted to prevent erosion, reduce maintenance, and improve overall appearance.

**PROCTOR TEST (#SD 104):** A moisture-density test to determine the optimum moisture content and resulting dry unit weight of material that can be expected from compaction at the OMC.

**REFERENCE POINTS:** Marked points used to locate or relocate definite points on centerline.

**REFERENCE STAKES:** Stakes placed along reference points that contain information about the reference point. (e.g. what the point is, station and offset distance)

**REPLACEMENT:** Disturbing original soils and replacing them to increase their ability for greater compaction.

**RIGHT OF WAY:** The outside property line and limits of a highway.

**RIGHT OF WAY (ROW):** Stakes that are set to define the property line and limits of the highway project.

**ROADBED:** The graded portion of a roadway within top and side slopes prepared as a foundation for the pavement structure and shoulder.

**ROADWAY ELEMENTS:** The basic elements of a road taken into consideration during planning, design, and construction. (Vertical line and cross section).

**ROCK EXCAVATION:** All hard rock in ledges, bedded deposits, or unstratified masses, so firmly cemented or held together that extreme measures must be taken for removal.

**ROUNDED SLOPE:** A sloped area that is convex in appearance and needs additional material removed to bring it to the proper design (cross-reference dished slope).

**SALVAGEABLE MATERIAL:** Pipe or other material that can be removed from the construction area and used elsewhere (e.g. soils, timber, structures, pipe).

**SELECT MATERIAL:** The best material available for building the upper portion of the roadbed.

**SLOPE STAKES:** Stakes that mark the point where the outer slopes of a cut or fill meet the original grade or ground.

**SOILS PROFILE:** A record of pre-construction soil samples tests, their location and laboratory analysis results.

**SPECIFIED DENSITY:** Obtaining a specific density as shown on the plans or specification and checked by in place density testing.

**STATIONS:** 100 foot intervals of centerline stakes (full or even stations). Points between full stations are referred to as "PLUS STATIONS."

**SUBBASE:** Material placed on the subgrade to assist in stabilizing and supporting base course material.

**SUBGRADE:** The top surface of the roadbed upon which pavement structure and shoulders are constructed.

**SUBSURFACE DRAINAGE:** The construction of drains beneath the surface in shoulder areas to keep ground water from reaching the upper levels of the subgrade.

**SURFACING:** The top or surface material (concrete or asphalt) of the pavement structure.

**SURFACE DRAINAGE:** That process of building a crown in the road and sloping shoulders to side ditches or gutters to provide a flow path for surface water (rain, snow, etc.).

**SURPLUS EXCAVATION:** Material taken from an area of excavation that is in excess of total fill requirements.

**TOP SOIL:** Humus bearing soil that will support plant life.

**UNCLASSIFIED EXCAVATION:** Any and all materials not otherwise classified, that are encountered during construction regardless of their nature or manner of removal.

**UNDERCUTTING:** A process of removing material from its natural location to a specified depth below the plan subgrade elevation.

**UNSTABLE (unusable) MATERIAL:** Those areas containing bentonite, wet, or soggy spots, that cannot be utilized for subgrade or subbase and must be removed.

**VERTICAL ALIGNMENT:** Plan profiles that represent the rise and fall of the road without regard to straight or curve sections.

**WASTING:** Disposal of surplus material, which involves the placement of such waste in areas that is of no actual benefit to the project. (e.g. spreading out material on slopes or cuts of the right of way just to get rid of it.)

# MEASUREMENT CONVERSIONS

## Metric Units of Measurement

---

Length = meter (m)

Mass = gram (g) or kilogram (kg)

Volume = liter (l) or cubic meter (m<sup>3</sup>)

Time = second (s)

Area = square meter (m<sup>2</sup>)

Velocity = meter per second (m/s)

Acceleration = meter per second per second (m/s<sup>2</sup>)

Work = joule (J)

Power = watt (W)

## Relative Values of Metric Prefixes

---

### Multiples and Submultiples Prefixes Symbols

1,000,000 = 10<sup>6</sup>megaM

1,000 = 10<sup>3</sup>kilok

100 = 10<sup>2</sup>hectoh

10 = 10dekada

0.1 = 10<sup>-1</sup>decid

0.01 = 10<sup>-2</sup>centic

0.001 = 10<sup>-3</sup>millim

0.000001 = 10<sup>-6</sup>microu

Unit of Measurement (N) = meter, gram, or liter	Multiple and Submultiple Prefixes					
	Milli N (m)	Centi N (c)	Deci N (d)	Deka N (da)	Hecto N (h)	Kilo N (k)
0.001	<u>1.0</u>	0.1	0.01			
0.01	10.0	<u>1.0</u>	0.1			
0.1	100.0	10.0	<u>1.0</u>			
<u>1.0</u>	1000.0	100.0	10.0	0.1	0.01	0.001
10.0				<u>1.0</u>	0.1	0.01
100.0				10.0	<u>1.0</u>	0.1
1000.0				100.0	10.0	<u>1.0</u>

## CONVERSION TABLES

---

### Linear Measure

---

#### Metric to U.S.

- 1 millimeter = 0.03937 inch
- 1 centimeter = 0.393701 inch
- 1 decimeter = 3.93701 inches
- 1 meter = 39.3701 inches
- 1 meter = 3.28084 feet
- 1 kilometer = 0.62137 mile

#### U.S. to Metric

- 1 inch = 25.4 millimeters
- 1 inch = 2.54 centimeters
- 1 inch = 0.254 decimeter
- 1 inch = 0.0254 meter
- 1 foot = 0.3048 meter
- 1 mile = 1.60934 kilometers

### Surface Measure

---

#### Metric to U.S.

- (1 hectare = 10,000 square meters)
- 1 square millimeter = 0.00155 square inch
- 1 square centimeter = 0.1550 square inch

1 square decimeter = 0.1076 square feet

1 square meter = 10.7639 square feet

1 square meter = 1.19599 square yards

1 hectare = 2.47105 acres

1 hectare = 0.00386 square mile

1 square kilometer = 0.3861 square mile

### **U.S. to Metric**

1 square inch = 645.16 square millimeters

1 square inch = 6.4516 square centimeters

1 square foot = 9.2903 square decimeters

1 square foot = 0.092903 square meters

1 square yard = 0.836127 square meters

1 acre = 0.404686 hectares

1 square mile = 258.99 hectares

1 square mile = 2.59 square kilometers

## **Measure of Volume and Capacity**

---

### **Metric to U.S.**

(1 cubic decimeter = 1 liter = 1000 cubic centimeters = 0.001 cubic meter)

(1 milliliter = 1 cubic centimeter)

1 cubic centimeter = 0.061024 cubic inch

1 cubic decimeter = 0.035315 cubic foot

1 cubic meter = 35.3147 cubic feet

1 cubic meter = 1.30795 cubic yards

1 liter = 61.0237 cubic inches

### **U.S. to Metric**

1 cubic inch = 16.3871 cubic centimeters

1 cubic foot = 28.3168 cubic decimeters

1 cubic foot = 0.0283168 cubic meter

1 cubic yard = 0.764555 cubic meter

1 cubic foot = 28.32 liters

## **Measure of Weight**

---

### **Metric to U.S.**

1 milligram = 0.0154 grain

1 gram = 15.432 grains

1 gram = 0.035274 ounce  
1 gram = 0.002205 pound  
1 kilogram = 2.20462 pounds  
1 metric ton = 1.1023 tons (net or short -2000 pounds)

### **U.S. to Metric**

1 grain = 64.80 milligrams  
1 grain = 0.0648 gram  
1 ounce = 28.3495 grams  
1 pound = 453.592 grams  
1 pound = 0.453592 kilogram  
1 net ton = 0.9072 metric ton

### **Liquid Measure**

---

#### **Metric to U.S.**

(1 liter = 1000 cubic centimeters; 1 milliliter = 1 cubic centimeter)  
1 liter = 1.05669 quarts  
1 liter = 0.264172 gallon  
1 cubic meter = 264.172 gallons

#### **U.S. to Metric**

1 quart = 0.946353 liter  
1 gallon = 3.78541 liters  
1 gallon = 0.003785 cubic meter

### **Compound Units**

---

#### **Metric to U.S.**

1 kilogram per meter = 0.6720 pound per foot  
1 kilogram per square centimeter = 14.223 pounds per square inch  
1 kilogram per square meter = 0.2048 pound per square foot  
1 kilogram per cubic meter = 0.0624 pound per cubic foot  
1 kilogram-meter = 7.233 foot-pounds  
1 joule = 0.7373 foot-pound  
1 kilowatt = 1.34102 horsepower  
1 kilogram-meter per square centimeter = 46.58 foot-pounds per square inch

#### **U.S. to Metric**

1 pound per foot = 1.4882 kilograms per meter  
1 pound per square inch = 0.0703 kilogram per square centimeter



1 pound per square foot = 4.8825 kilograms per square meter

1 pound per cubic foot = 16.0192 kilograms per cubic meter

1 foot-pound = 0.1383 kilogram-meter

1 foot-pound = 1.356 joules

1 horsepower = 0.74570 kilowatt

## ANSWERS TO MANUAL'S PROBLEMS

### Page 3-19

#### FORCE ACCOUNT SUMMARY

Project F0212(48)267

Contractor \_\_\_\_\_

Sub Contractor \_\_\_\_\_

A.1. Labor A.1. 27.23

A.2. 15% of Labor ((0.15xA.1.) A.2. 4.08

B. Bond, etc. 27.1% of Labor Only (.271xA.1.)\*B. 7.38

Excludes 15% for overhead

C.1 Material C.1. 591.27

C.2. 15% of Materials (0.15xC.1.) C.2. 88.69

D. Equipment D. 173.93

E. Subcontracting (if applicable) A.1.+A.2.+C.1.+C.2. only E. -

Use table:

\$0 to \$1,000.....10%

\$1,000.01 to \$10,000....\$100 + 5% of excess over \$1,000

Over \$10,000.01.....\$550 + 3% of excess over \$10,000

F. Profit - 10% of Total Labor & Materials F. 71.87

(0.10x(A.1.+A.2.+B.+C.1.+C.2.))

Total Force Account (add all lines)= 964.45

\*Unless Contractor provides a documented percentage to use in this space, use 27.1% as per 2004 Spec Book. Therefore you would multiply A.1. by 0.271.

**Page 7-44**

$$10,000 \times 0.3 = 3,000$$

$$48,378 \times 0.25 = 12,094.50$$

$$5.7 \times \$200.00 \times 1 \text{ yr} = 1,140$$

$$\text{Total} = \$16,234.50$$

**Page 7-51**

$$505 + 54.99$$

$$531 + 72.24$$

**Page 7-52**

$$18,910$$

**Page 8-65**

$$7.5:1$$

**Page 8-66/67**

1) 42'

2) 4.29

3) 1229.16

4) 1228.91

# Pipe Installation



Chapter 1	
INTRODUCTION	3
SAMPLING AND TESTING	3
RECORDS	3
Chapter 2	
TYPES OF PIPE	5
METAL PIPE	5
CONCRETE PIPE	6
PIPE SHAPE	7
Chapter 3	
PIPE ENDS	9
CLEAR ZONE	9
PIPE END TREATMENTS	10
Chapter 4	
PIPE NOTES	12
FIELD NOTES	20
Chapter 5	
PIPE LOCATION	21
Chapter 6	
TAKE OUT PIPE	24
Chapter 7	
PIPE EMBANKMENT	25
FOUNDATION	25
UNDERCUTTING	26
CAMBER	29
BEDDING	32
CRADLE	32
PIPE PLACEMENT	37
BACKFILL	38
NORMAL TYPE BACKFILL	39
IMPERFECT TRENCH	39
TRENCH INSTALLATION	42
Chapter 8	
FIELD TESTING	47
TEST LOCATIONS	48
Chapter 9	
UNDERDRAINS	49
Chapter 10	
REJECTION	50
RC PIPE 58	
CMP (CORRUGATED METAL PIPE)	58
Chapter 11	
FINAL INSPECTION	59
Chapter 12	
PIPE SPECIFICATION REFERENCES	60
Chapter 13	
PRECAST CONCRETE BOX CULVERTS AND LARGE PIPE OR ARCHES	61
FABRICATION	61

INITIAL FIELD INSPECTION - - - - -	61
BEDDING - - - - -	62
INSTALLATION - - - - -	63
JOINTS - - - - -	63
STRUCTURE EXCAVATION, BOX CULVERT - - - - -	64
UNDERCUTTING CONCRETE BOX CULVERT - - - - -	64
HANDLING - - - - -	64
INSTALLATION SEQUENCE - - - - -	65
Chapter 14	
ANSWERS TO MANUAL'S PROBLEMS - - - - -	74

All figures cited in this manual are in the envelope at the back of the manual.

Note: Throughout this manual, reference is made to provisions of the South Dakota Standard Specifications for Roads and Bridges. For example, (120.3 A.) refers the reader to Section 120.3 paragraph A, Excavation in the specification book.

Additional manuals that the Pipe Installation inspector should be familiar with are:

- Materials Manual
- CMP Manual
- Survey Manual
- Earthwork Manual
- Erosion Control Manual

This book should be kept by the Pipe Installation Inspector as a reference guide during the performance of his duties. If, after participating in the course or during construction, you have ideas or suggestions for improving the course submit them for incorporation in future training courses.

The Department of Transportation is grateful for and wishes to recognize the efforts of its employees who have made significant contributions to the improvement of this training manual. Those employees include:

Matt Stone, Rapid City

# 1

## INTRODUCTION

Pipe installation is an essential part of earthwork construction. It is at pipe locations that many bumps in the road are located. Therefore, the pipe installation inspector must assure that the pipe is placed according to the Specifications.

This manual is provided to aid and assist the Pipe Inspector in their task. This course contains important instructional material, procedures and policies that have been developed to maintain uniformity among Pipe Inspectors. This course will cover what you need to know, do, and look for during the inspection of pipe installation.

Communication is one of the most important aspects of an inspector's job. The inspector helps the Contractor anticipate problems and helps find ways to resolve them. The inspector is friendly but firm and impartial in making decisions when dealing with the Contractor and their personnel.

## Sampling and Testing

---

Sampling and testing are methods of evaluating the quality of the work. The inspector must:

- Know where and how to correctly sample.
- Make sure that every sample is identified with the proper information.
- Be equally as confident and knowledgeable about prescribed testing procedures and documentation of tests.
- Follow the Materials Manual guidance.

## Records

---

One of the most important functions of the inspector is to keep accurate records and document thoroughly.

- Records and reports should be kept current and submitted on schedule.
- They should be neat, complete and legible.
- In addition to standard forms, the inspector should keep a diary of activities.
- Any item of significance should be recorded.
- Records and reports are used to determine quantities of materials for payment.



- They ensure that the Contractor is paid fairly.
- The quantity records must be complete and accurate.

## TYPES OF PIPE

There are two major types of pipe: metal and concrete. In addition there are several other types of pipe, which will not be covered in this manual: perforated, downspouts, and edge drain.

### METAL PIPE







---

Metal pipe is made from sheets of steel either riveted together or spiral crimped together and coated with zinc alloy to prevent rust. Metal pipe is normally corrugated and is referred to as CMP (Corrugated Metal Pipe). This corrugation may sometimes be helical, meaning spiral.

- The thickness of the metal in CMP is measured in terms of gauge.
- The larger the number, the thinner the metal.
- A pipe constructed of 10 gauge metal is much thicker than one constructed with 16 gauge metal.
- Certain soils and conditions will corrode metal pipe.
- They may be coated with asphalt or asbestos fibers and asphalt for protection.
- All corrugated metal pipes may not be perfectly round.
- Some larger sizes are elongated, or oblong, in one direction about 5% weight of fill above the pipe pushes down.
- The long axis of an elongated pipe should be placed vertically.
- Another type of metal pipe is structural plate pipe.
- Structural plate pipe is made from many sheets of corrugated metal, which are normally bolted together at the job site.
- The thickness or gauge and type of corrugation of the pipe vary with the height of cover above the top of the culvert.
- When there are two 36" CMP on a job and one is 16 gauge and the other is 12 gauge.
- The 12 gauge pipe would most likely be placed under the higher fill.
- The Table in Appendix C gives the gauge and type of corrugation of corrugated metal pipes required under various heights of cover.

- The minimum cover for all corrugated metal pipes 96" and less is 1' as measured from the subgrade.
- All pipes greater than 96" shall use 18" minimum subgrade cover.
- CMP comes in different strengths.
- The following chart shows the different pipe gauges:

**Figure 2.1**

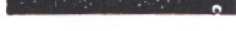
GAGE		THICKNESS
16		0.064
14		0.079
12		0.109
10		0.138
8		0.168
5		0.215
1		0.276

## CONCRETE PIPE

---

Pipe constructed from concrete is made with reinforcing steel inside the pipe. This is referred to as RCP (Reinforced Concrete Pipe).

- The strength of concrete pipe is rated in terms of 5 different classes, Class I, II, III, IV, and V.
- Class II is normally specified unless the plans specifically require another class. A higher class than specified may be used.
- Only Class II, III, IV, and V are used in South Dakota.
- RCP comes in different strengths and are rated by class.
- The higher the class, the stronger the pipe.
- All of these classes will fit each other.
- Pipe installation may have two classes of pipe or even three.
  - If so, the higher class will be under the higher fill.
- RCP gets more strength by adding more reinforcing steel.
- To determine where the higher class of pipe should be placed, check the sketch in the DOT -214 or cross section for that pipe.
- Class V pipe would be under more fill than Class III or IV.

- The minimum cover over concrete pipe is 1'.
- Typically, Class V pipe is used for a distance of 25' - 30' either side of centerline of railroad tracks or to the ROW line whichever is less.

**Figure 2.2**

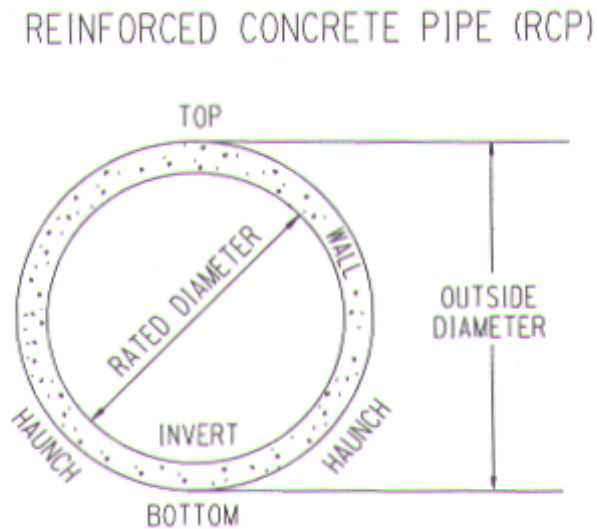

The rated diameter of RCP is different than the outside diameter. The rated diameter refers to the inside diameter of the pipe.

RC pipe is tongue and grooved to allow for the placement of sections end to end.

**Figure 2.3**

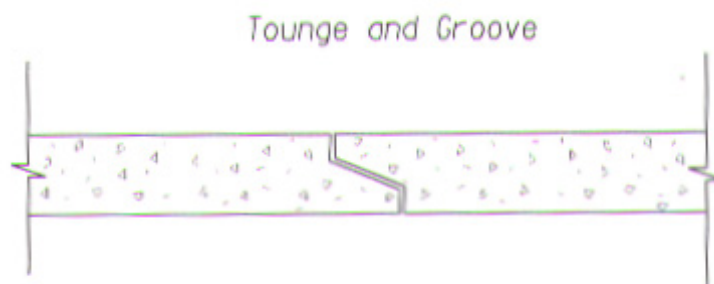

## PIPE SHAPE

---

Pipes come in all sizes and shapes.

- An arch pipe is used when the roadway is low and there is not enough room for a round pipe.
- A cattle pass pipe is used to move livestock or something other than water, from one side of the roadway to the other.

- The plans and Standard Plates will indicate the size, type, and details for the pipes being installed on the project.

**Figure 2.4**

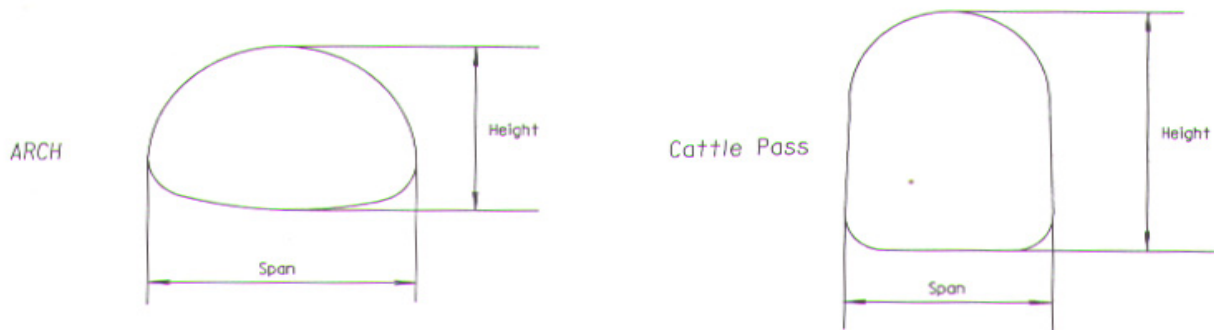

Standard Plate 450.10 (Appendix A) shows a flared end that is used to slow water at the outlet by spreading the water flow. They also collect water at the inlet and funnel it into the pipe. Flared ends may be constructed of RCP or CMP. Standard Plates 450.22 and 450.13 (Appendix A) shows safety ends and sloped ends that are used at pipe inlets and outlets to allow errant vehicles to safely travel over them. The safety ends and sloped ends may be constructed of RCP or CMP and bars may be required as an additional safety feature.

- A transition is a length of RCP and a piece of CMP cemented in place. They are used to change from one type of pipe to another.
- A tee section is used to connect other sections of pipe to a main line.
- A bend is used to change the direction of a pipe.

## PIPE ENDS

### CLEAR ZONE

---

Once a vehicle has left the roadway, an accident may or may not occur. The end result of an encroachment depends upon the physical characteristics of the roadside environment.

An adequate clear zone distance between the edges of traffic lanes and roadside obstructions is an important safety factor.

The Department clear zone policy states the following:

- For reconstruction and new construction of all rural highways (including interstates), a 30' clear zone shall be used.
- For reconstruction of urban projects, 6' is desirable (measured from the back of curb), with 2' being a minimum.

**Figure 3.1** Illustration of clear zone

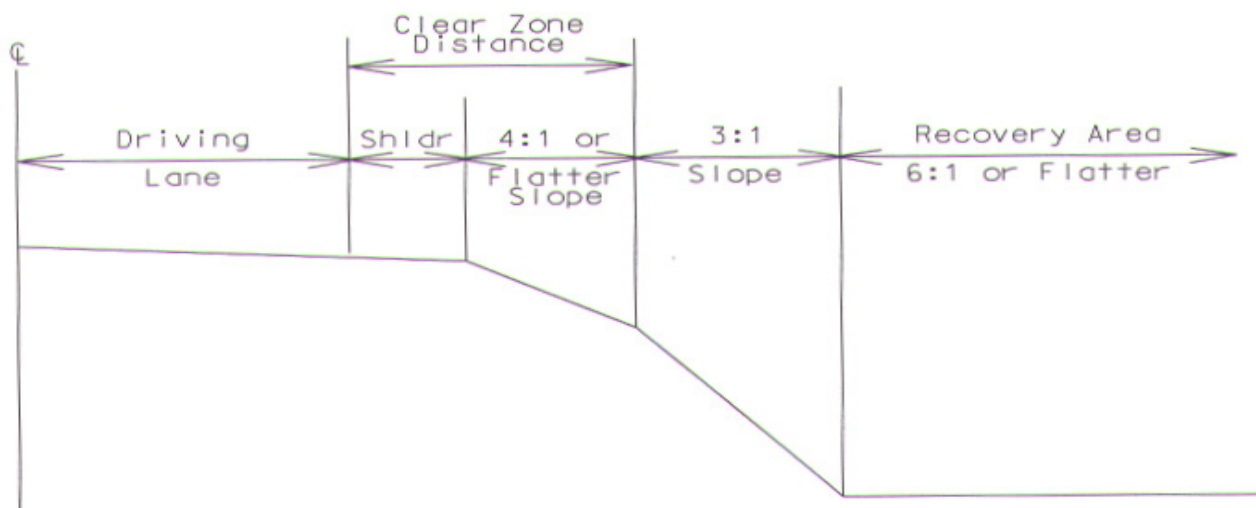

# PIPE END TREATMENTS

The following information is obtained from Roadway Design Manual Chapter 10- Roadside Safety. Make sure to check the current version for pipe end treatment in the Roadway Design Manual.

Pipe culverts, box culverts and cattle passes

## Transverse to mainline treatment for pipe culverts, box culverts, and cattle passes for construction/reconstruction (Non-Interstate).

Relation to Clear Zone (1)	Cross Pipe Size	Type of End Treatment on Cross Pipe
Inside or Outside	24" & 30"	Sloped End <b>*Without</b> Protective Bars
Inside	36" & Larger Pipe, All RCBC & All Cattle Passes	Not allowed inside clear zone unless barrier protection is deemed justifiable
Outside Only	36" thru 60"	Flared End (2)
Outside Only	60" & Larger, All RCBC & All Cattle Passes	Flared End, Sectional Apron or Wing Wall depending on structure

- 1) Refer to section on clear zone in this chapter.
- 2) When the fill slope above the pipe is flatter than a 4:1 inslope, a proper transition length must be provided to attain the flatter inslope. See Chapter 7- Cross Sections and Standard Plate 120.05 for appropriate inslope transition.

## Approach treatment for construction/reconstruction (Non-Interstate)

Relation to Clear Zone (1)	Approach Pipe Size	Type of End Treatment on Approach Pipe	Approach Slope
Inside	18" & 24"	Safety End <b>** Without</b> Protective Bars. For Multiple pipe installations, protective bars may be considered	6:1 (2)
Outside	18" & 24"	Safety End <b>without</b> Protective Bars	6:1 (3)
Inside	30" thru 60"	Safety End <b>with</b> Protective Bars	6:1 (2)
Outside	30" thru 36"	Safety End <b>without</b> Protective Bars. Protective Bars may be provided where deemed appropriate.	6:1 (3)
Outside	42" thru 60"	Safety End <b>with</b> Protective Bars (4). Flared ends may be considered if there is measurable cost savings.	6:1 (3)
Outside ONLY	Larger than 60"	Flared Ends shall be considered or consider smaller multiple pipe and end sections.	6:1 (3)

- 1) See section on clear zone in this chapter.
- 2) When no pipe is installed a 10:1 should be considered.
- 3) When no pipe is installed and in normal ditch section a 10:1 should be considered. When pipe is installed and where the distance for slope to intercept the original ground is

excessive, a 4:1 may be considered as long as a 6:1 is used within the mainline highway clear zone and the intercept point of the approach slope and original ground or ditch profile is rounded. The 4:1 may be considered only outside of the clear zone if there is measurable cost savings.

4) Protective bars to be provided for structural reasons.



## PIPE NOTES

Every job has paper work. For pipe installation, it is form DOT - 214. One is used for each pipe. The forms are kept in a three ring binder because there are usually a number of pipes to be installed on a project.

The DOT - 214 states where the pipe will go and how it should be installed. It is also a record used to pay the Contractor for installation. Part of the DOT - 214 may be completed in the office and part by the survey crew. This chapter is basically how to fill out and use a DOT - 214 form.

The first page consists of project information:

- There are blanks for the PROJECT NUMBER and COUNTY at the top of the DOT - 214. This information is on the Title page of the project plans.
- When the project is staked the members of the SURVEY CREW, the WEATHER, an DATE STAKED should be filled in on the DOT - 214.

The second page consists of survey information:

- There are blanks for both STATION and INSTALL. Install means what type of pipe, what size, what length, how many flared ends and what skew, if any, is required.
- The next blank is for the type of Bedding.
  - There are three types of bedding; they are Class A, B, and C.
  - The most common type is Class C. It is used unless a different class is named on the plan sheets.
  - Use Class C when the class is not shown on the plan sheets.
- Below the BEDDING is a blank for BACKFILL. The methods used to backfill a pipe are either normal or imperfect trench. Normal backfill is always used unless another method is named in the plans.
- The DISTANCE right and left of the centerline must be obtained from the cross section. The distance is calculated to the end of the flared or sloped end.

(Remember the scale for cross sections is 10' for each horizontal large square and 5' for each vertical large square unless otherwise marked on the sheet.) Use plan and profile sheets to obtain inlet and outlet elevations.

Each vertical small square equals 6" and each horizontal small square equals 1'.

- The FLOWLINE (F.L.) is the elevation of the pipe at the inlet end section and outlet end section. The flowline is usually the last item on the DOT- 214 to be filled out. Sometimes it must be taken from the cross sections.
- Look on the plan profile (Figure 1) and find the inlet and outlet elevations for the pipe at 516 + 85.0. Inlet is 2731.5 and outlet is 2729.5 on the plan profile. When flowlines are not listed on the profile, get them from the cross section (Figure 2).
- For the rest of those blanks: H.I., G.R., and C (CUT) or F (FILL) H.I. is the Height of Instrument or the elevation of the survey crew's level when the pipe was staked.
- Directly below that is the flowline elevation, which is completed in the office.

The next item on the DOT - 214 is the LEVEL NOTES. These are figures used to get a known elevation to stake the pipe. That known elevation is the H.I., or height of instrument.

- Level notes are divided into 6 columns:
- Column 1 - Description, such as BM or turning point.
- Column 2 - "Back Shots" are readings taken on a known elevation to find the elevation of the level.
- Column 3 - Elevation of the level.
- Column 4 - "Forward Shots" are taken to find unknown elevations of the rod.
- Column 5 - Elevation of the rod.
- Column 6 - Elevation of benchmarks.

Below is an example of a set of level notes. All calculations and notes should be reviewed.

**Table 4.1** Level Notes

BM 24			14.30	1476.05	1476.07
	2.35	1490.35	12.30	1488.00	
BM 23	0.25	1500.30			1500.05

The known elevation points are called BENCHMARKS, or B.M. To show how level notes are done, each operation is a separate line. In the field, the notes will look like the previous illustration.

**Figure 4.1**

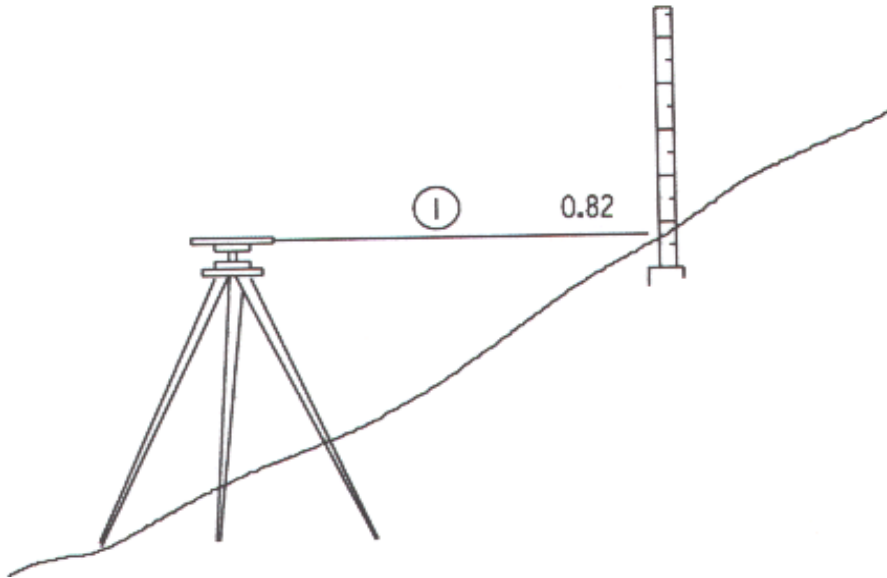

To get the instrument elevation (H.I.) add 0.82 to the BM elevation.

**Table 4.2** Level Notes

BM 17	1496.13
-------	---------

The elevation of a benchmark is indicated in the bottom of the first column of the above illustration. The BM number is BM 17.

To find an elevation for level, the instrument man will take a reading from a rod placed on the benchmark. For example, the reading is 0.82, which means that the instrument is 0.82 higher than the benchmark.

**Table 4.3** Level Notes

BM 17	0.82	1496.95	1496.13
-------	------	---------	---------

The pipe may be a great distance down a hill. The instrument will need to be moved and a new elevation obtained. With the level at 1496.95, a reading was taken at 10.38 on a rod further down the hill. The point of elevation the rod is resting on is 10.38' less than the elevation of the level.

**Figure 4.2**

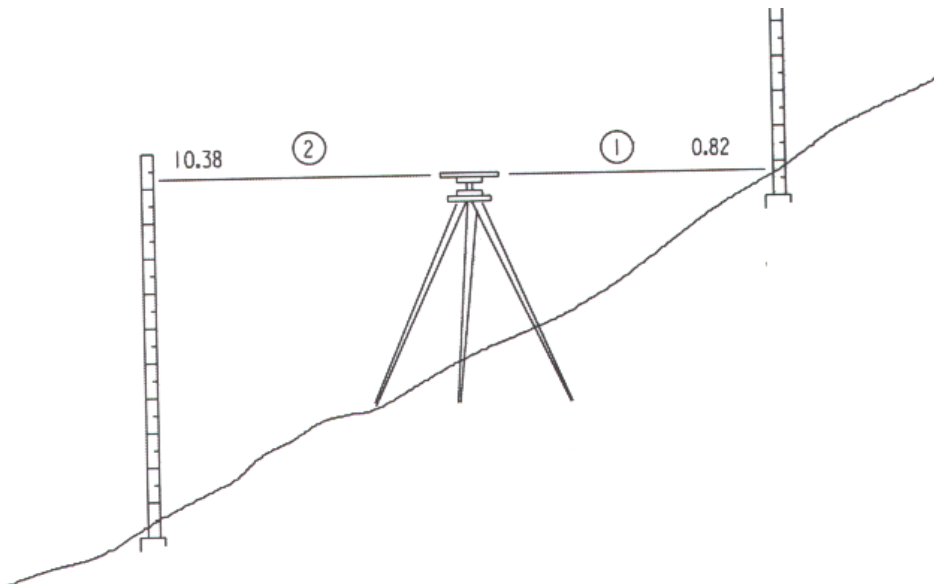

The instrument person knows the elevation of the point where the rod is resting and has moved the level down hill. Next, find the new elevation (H.I.) for the level. Add 0.82 to BM to get H.I. Subtract rod reading of 10.38 to get elevation at position # 3. Add 2.44 to get H.I. at position # 2 1489.01.

**Figure 4.3**

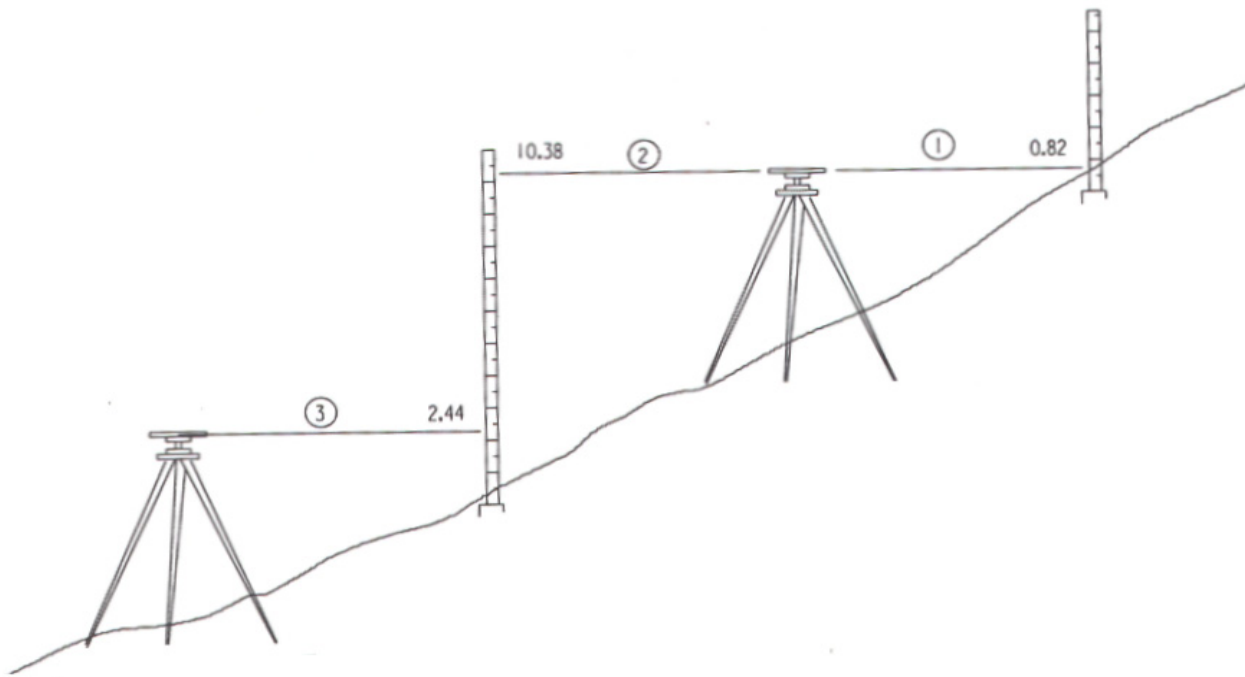

The new elevation of the instrument is 1489.01. The level, but not the rod, was moved during the operation of turning.

Notice how level notes are done.

- When finding the elevation of the level, enter the reading in the second column and add to get the level elevation.
- To find the elevation of some point lower than the level, subtract the reading from the level elevation.

The elevation 1489.01 is H.I. used to stake the pipe. After staking the pipe the survey crew will check back to a bench for accuracy. They will check the same benchmark. The rod is set at a new point up the hill and they get a reading of 1.78. Remember that figures in the fourth column are subtracted.

**Table 4.4** Level Notes

BM 17			3.24	1496.13	1496.13
	12.14	1499.37			
			1.78	1487.23	
	2.44	1489.01			
			10.38	1486.57	
	0.82	1496.95			
BM 17					1496.13

Notice that in the following set of level notes the survey crew checks back to a different bench, 53. The figure in the fifth column is the elevation the survey crew has measured for that benchmark. The figure in the sixth column is the actual elevation. It is off by 0.04. Survey crews should check back into a bench with plus or minus 0.05 accuracy. 0.04 is within this accuracy.

**Table 4.5** Level Notes

BM 53			9.08	1670.23	1670.19
	12.58	1679.31			
BM 52					1666.73

Survey notes, may not be spread out on separate lines. The following is an example of proper survey notes.

**Table 4.6** Level Notes

BM 37			2.78	1591.08	1591.08
	7.23	1593.86	4.23	1586.63	
BM 36	12.54	1590.86			15.78.32

**Figure 4.4**

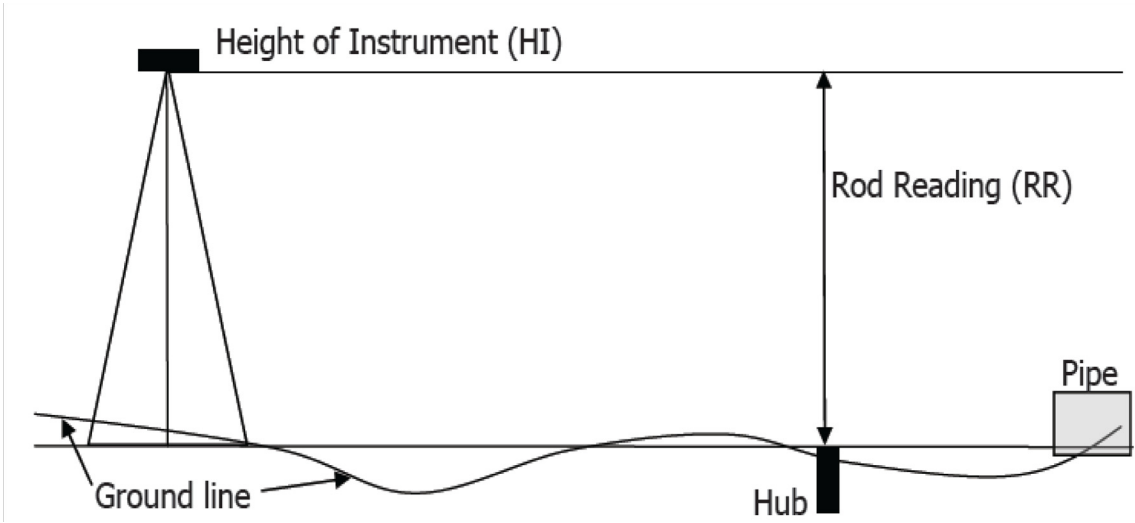

- The flowline (F.L.) is measured at the end of the installation.
- It is not possible to place a stake at the end of the pipe. It would be in the way of construction.

- The stake should be offset usually 20' to 30'.
- The survey crew takes a shot on the top of the hub to get the rod reading (RR).
- Subtract the RR for the HI to get the elevation of the offset hub.
- Subtract the hub elevation from the design elevation. If it is a positive number, it is a fill (F) stake. If it is a negative number, it is a cut (C) stake.

**Figure 4.5**

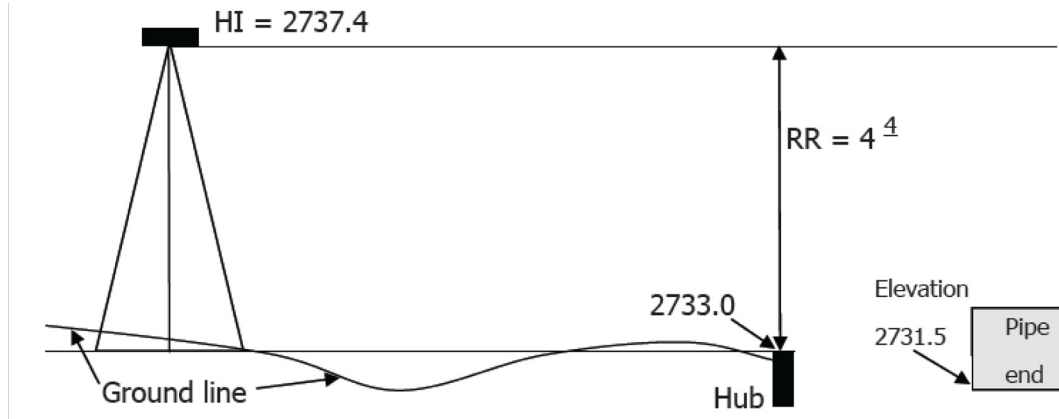

Using the information above, is it a cut or fill and how much? \_\_\_\_\_.  
There will be actually two stakes at each end of the pipe.

- One is the hub, which is driven flush with the ground and is the reference point. The R. R. is taken on the hub and is used to measure with a hand level from this point when the pipe is installed.
- The other stake is known as the guard stake. This is the stake that has the information the Contractor will use to set the pipe.

Below is an example of a guard stake:

**Figure 4.6**

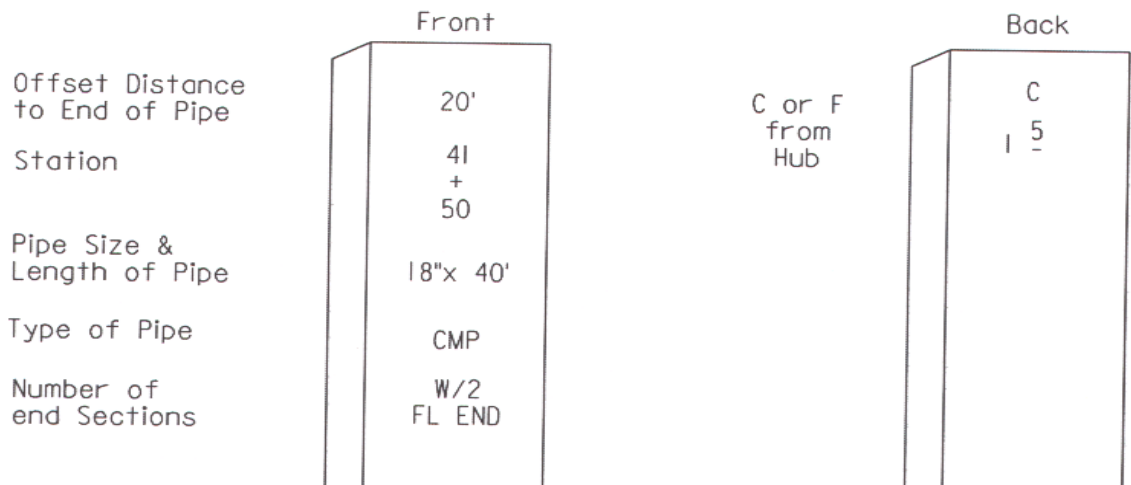

This information can be determined from the guard stake:

- The hub is 1.5' higher than the flowline at the end of the pipe.
- It is 20' to the end of the pipe.
- It is and 18" CMP type pipe.
- The pipe is at station 41+50.

- The pipe is 40' in length.
- The flared ends will be needed.

Hubs and guard stakes will normally be placed in this manner:

**Figure 4.7**

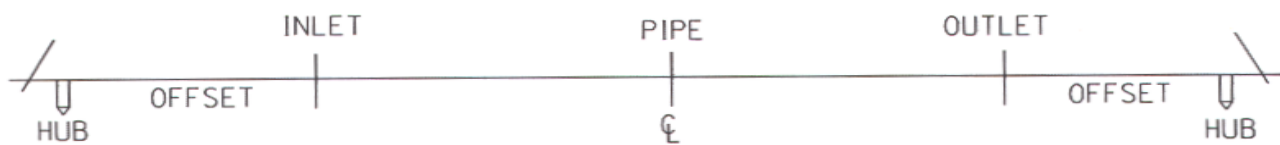

- There will be two hub stakes and two guard stakes usually as shown in the above illustration.
- The hubs and guard stakes may be set differently if the stake is placed in the way of construction.

**Figure 4.8**

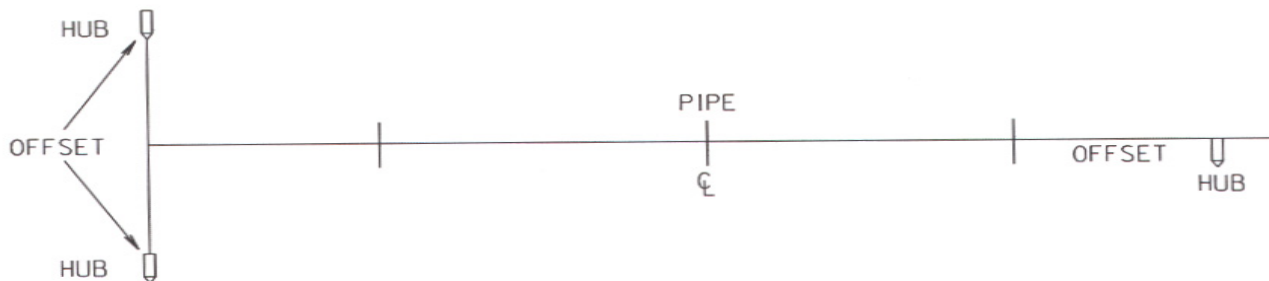

The guard stakes also indicate the distance right or left of the pipe centerline.

The third page consists of a Sketch and Cross Section:

The following SKETCH is to show the location of the different classes of pipe:

**Figure 4.9**

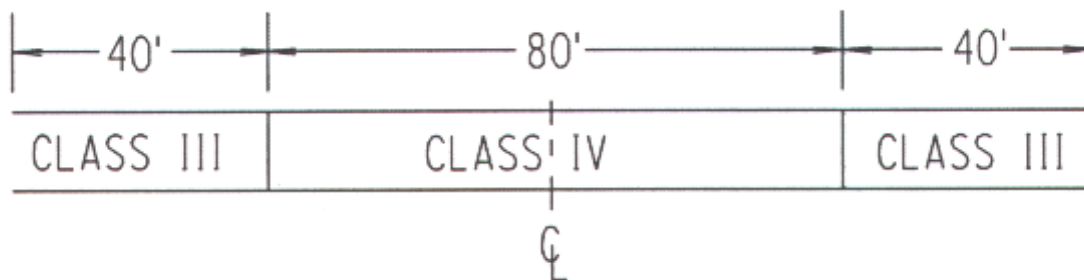

Below is another type of sketch on a skewed pipe. The offset distances are 20'. It is 120' long and skewed at 15° R.H.F. (Right Hand Forward).





# FIELD NOTES

---

- Pipe Installation is documented on the last page of the DOT - 214.
- All RCP are stenciled with the manufacture date, class of pipe, and manufacturer or trademark.

Below is an example of what would be stenciled on a section of 24" pipe produced in Rapid City March 12, 1999:

3-12-99          CL III CRETEX RC

The installation notes require the following information:

- Heat No. or Date:
  - CMP - Heat Number is stamped on the pipe
  - RCP - Date stenciled on pipe
- Class or Gauge
  - RCP - Class stenciled on the pipe.
  - CMP - Gauge is stamped on pipe.
- No. of Sections: Record the number of sections placed.
- Length of Section: Record length of section.
- Date Releases: (RCP only) Refer to Appendix B for Example "Tabulation of Concrete Pipe Dates." - Release date for the above Example is 3-16-99.
- Date Installed; Record date section of pipe installed.
- Pipe Company:
  - CMP - Obtain from certification.
  - RCP - Company or Trademark stenciled on pipe. "CRETEX" is a Trademark for South Dakota Concrete Products. See Appendix B.
- Company Location
  - CMP- Obtain from certification.
  - RCP - Location Stenciled on pipe.
- Total Installed: Record total pipe to be paid.
- Installation Complete: Date the pipe installation complete.
- Pipe Inspector: The inspector's signature.

## PIPE LOCATION

In a few instances, the location of a pipe, as noted on the plans may not be the best location. Pipes should be placed in the natural drainage channel unless the channel is changed.

Look beyond the ends of the pipe when inspecting a pipe location. Check to see which way the drainage runs as the location and elevation should fit the natural drainage.

**Figure 5.1**

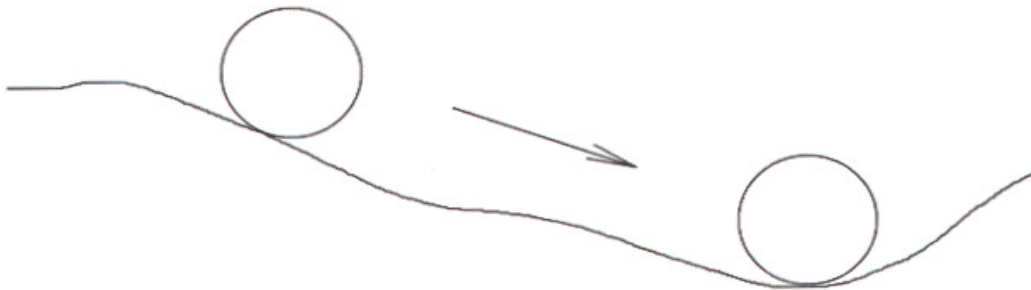

- Natural waterways and drainage areas are not permanent.
- There may be channel changes in any drainage area.
- Channels can become higher from silting or deeper from erosion.
- They can become straighter or more winding.
- The drainage area may change affecting the amount of runoff and the amount of silt and debris.
- The runoff will be greater if a drainage area that was formerly a grass covered field has been changed to a paved parking lot.

The first principle of a good pipe location is a direct entrance and exit.

- An abrupt change in the direction of flow at either end of the pipe can affect the performance of the culvert and cause erosion.
- Provide a direct entrance and exit for pipes by one of two methods.
- One is to skew (angle) the pipe and the other is to change the channel.

This illustration shows poor alignment because it does not provide direct entrance and exit.

**Figure 5.2**

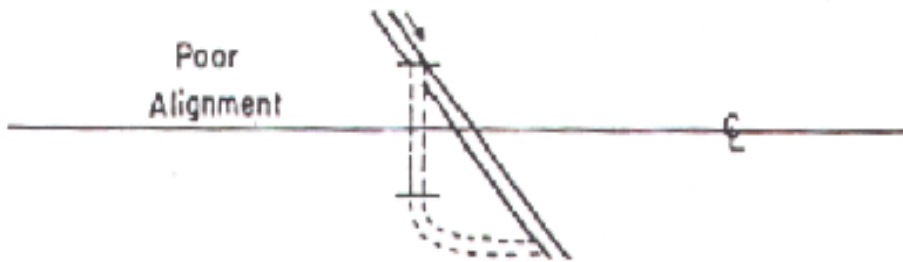

This illustration shows that poor alignments can be corrected. This pipe has been skewed to provide good alignment.

**Figure 5.3**

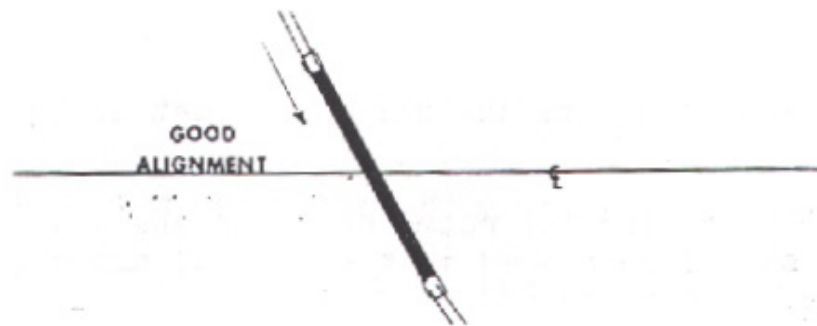

A change in the flowline of a pipe will usually change the length of the pipe.

- For example the flowline is a 1' lower at the outlet than had been called for on the plans
- If the slopes are 5 to 1 then the toe of the slope will be 5' further out.
- The pipe will also have to extend five more feet.
- If the outlet is raised 2', again assuming 5 to 1 slopes, the pipe will be 10' shorter.

Another item that affects the length of the pipe is the extent to which it sticks out of the slope. This presents no problem on flared end installations, however, where there is no flared end there is a right or wrong way of doing things. Pipe should meet the slope half way up the pipe as shown in the following illustration.

**Figure 5.4**

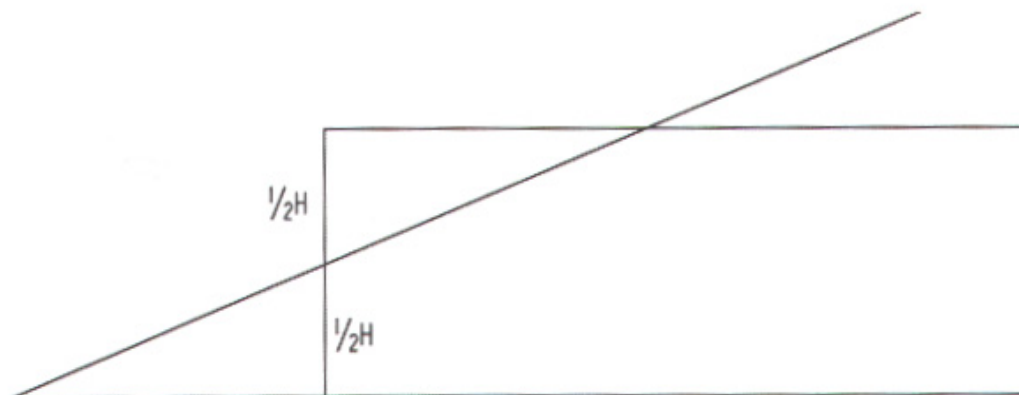

Use the following Pipe - Slope Chart when determining the Fit for Skewed Pipe. When a pipe is skewed the slope should meet the pipe at the correct%.

**Table 5.1** Pipe - Slope Fit for Skewed Pipe

<b>% of Skew</b>	<b>% of Pipe Height</b>
0-10	50
10-20	40
20-30	25
30-40	0

EXAMPLE: The slope should be 25% for a pipe with a 27° skew.

When the location, flowline, length, distance from the centerline, or anything else about the pipe is changed it should be noted under the Additional Notes on the DOT - 214.

**TAKE OUT PIPE**

Refer to Section 110 of the Standard Specifications:

Pipe that is removed shall be removed and disposed of as nonperishable material.

“Nonperishable material may be disposed of outside the limits of view from the project with written permission of the property owner.”

Pipe to be reset shall be removed, transported to the site of installation and stored, so there will be no damage before resetting. The Contractor will be required to replace sections of pipe damaged by negligence.

Example

Pipe take out	
522+69-27'L	8-12-01 TH
Take out 18" x 62' CMP	
624+52	8-14-01 TH
Take out 36" x 72' RCP	
Actual quantity removed 36" x 78' RCP	

## PIPE EMBANKMENT

Pipe installation can be broken into several operations:

- Foundation - This is the material below the pipe.
- Bedding - The actual surface the pipe is laid on.
- Backfill - The entire fill above the bedding.

**Figure 7.1**

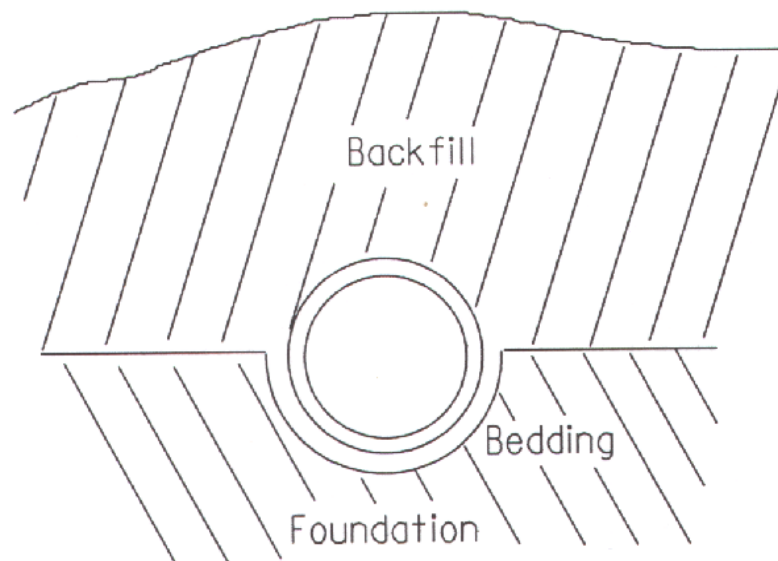

### FOUNDATION

---

Soil around the pipe must be compacted. Pressure and moisture are needed. Pressure is needed to push the soil particles together and moisture to make the particles compact easier. For correct moisture content, look at plan notes and Section 120 of the Standard Specifications.

- A piece of equipment may be used for compacting.
- It is important to get the same amount of compaction across the entire soil area.
- The foundation should support the pipe evenly along the entire length.

- If one part of the foundation is hard and another soft, the pipe will settle unevenly.
- 6" to 8" below the lower face of the pipe must be at project density and moisture requirements to get a solid, uniform foundation.
- When the flowline is at or below ground line, the Contractor will have to loosen or scarify down to 6" or 8" below the lower face of the pipe.

**Figure 7.2**

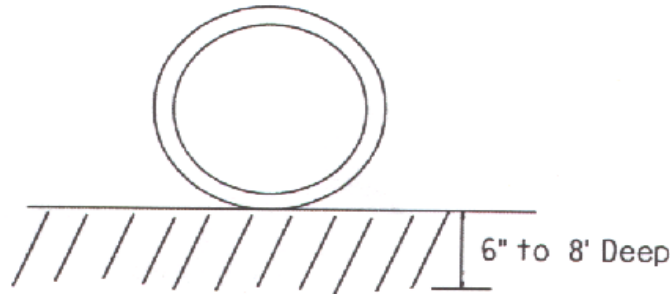

- If the pipe foundation is in embankment rather than natural ground, it will not be necessary to scarify and recompact because it has already been done.

The Contractor should bring the foundation back up above the flowline of the pipe when re-compacting. Just how far will depend on the type of pipe and the type of bedding.

- The foundation must meet requirements for density and moisture.
- Tests should be taken in the poorest spot in the foundation.
- The poorest spot will be the spot that seems spongy when the tires of a motor grader pass over it or where clear footprints are left after walking over the area.
- Develop a method of estimating moisture in soils.
- One way to estimate moisture is by squeezing a handful of dirt.
- The dirt should stick together when squeezed. Break the dirt apart.
- It should break cleanly, without crumbling.
- If the dirt sticks to the hand rather than sticking together, it has too much moisture.
- Check against tests on materials to confirm.
- The test results must be within moisture specifications.
- If the foundation does not have enough density it may need more compaction, more moisture, or both.
- If a foundation has enough moisture but does not have enough density, the Contractor should compact the material by rolling it.
- When there is not enough moisture, have the Contractor either add moisture and work it in or have him replace the dry material with pre-moistened material. Either way is acceptable on foundations.
- The material should be removed if the foundation will not come up to the required density and the area has too much moisture.

## **UNDERCUTTING**

---

When the foundation is too soft or has undesirable material, it has to be undercut. The soft or poor material must be removed.

Undercutting is the process of removing the earthwork below the pipe bedding and replacing it with a suitable material to replace the undercut material.

The plans will typically provide the following note and table:

Undercutting pipe culvert:

The Engineer may direct undercutting of pipe not included in these plans. Under this item of work, the removal of unstable material and rock, either in ledge or boulder formation, below the bedding grade of pipe culverts and the backfilling of undercut areas shall be performed. If the engineer determines field conditions warrant change, the limits of undercutting may be increased, decreased, or eliminated.

This work will be paid for at the contract unit price per cubic yard, under the bid item UNDERCUTTING PIPE CULVERT. This payment will be full compensation for equipment labor, tool and incidentals required for undercutting and for furnishing, placing and compacting backfill material, including water, in place of the excavated material.

TABLE OF UNDERCUTTING PIPE CULVERT

Location	Quantity (Cu.Yd.)
24 + 49	27
36 + 78	88

Undercutting Pipe culverts must be documented.

If any quantities and Bid Item are not provided this is extra work that was not foreseen, the Contractor has to be paid extra. The Special Provision Regarding Price Schedule for Miscellaneous Items will provide the unit price the Contractor will be paid.

- The Contractor is paid for undercutting below the lower face of the pipe, except the upper limit for pipe culverts to be installed on a Class B bedding will be 1' below the lower face of the pipe.

Figure 7.3

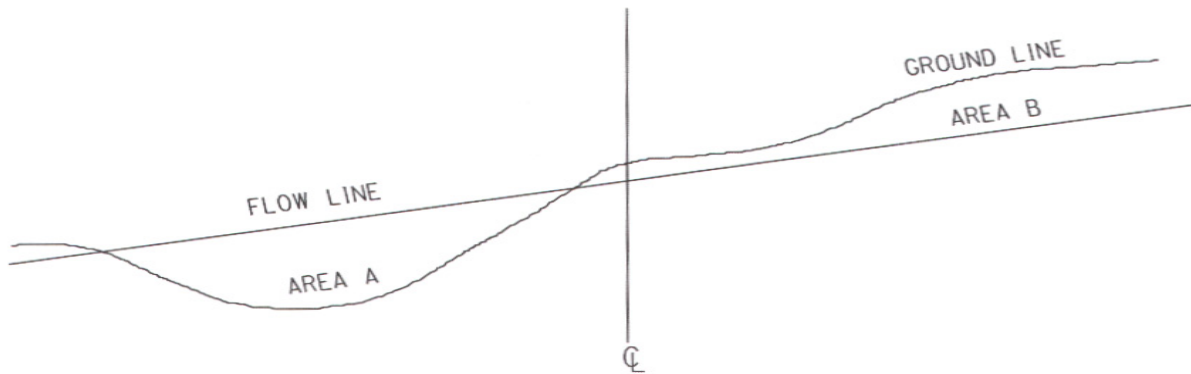

- The Contractor will not be paid for undercut excavation above the flowline, marked Area B right of centerline.
- Measurements are needed to determine how much undercut the Contractor should be paid for.
- The inspector on the job does the measuring and tells the Contractor where to undercut and how long and wide it should be.
- The width of the undercutting should be equal to the outside diameter of the pipe plus 4' or the outside span of arch pipe plus 4'.



- The Contractor should be paid only for the undercutting he is ordered by the state to do.
- Sometimes the Contractor will excavate material that does not need to be taken out in order to get to the material that does need to be undercut. This is unavoidable in many cases. However, the Contractor should not be paid for the material excavated that did not need to be undercut.

To know how much the Contractor has to be paid for undercut, the inspector has to determine how much poor material has to be taken out. The soft spot that has to be undercut will be measured for the distance from the nearest hub and length.

- The below illustration shows that the hub is 80' from the excavation.
- Next determine the depth of the material that must be removed.
- To get the depth, the undercut is cross-sectioned by the survey crew.

**Figure 7.4**

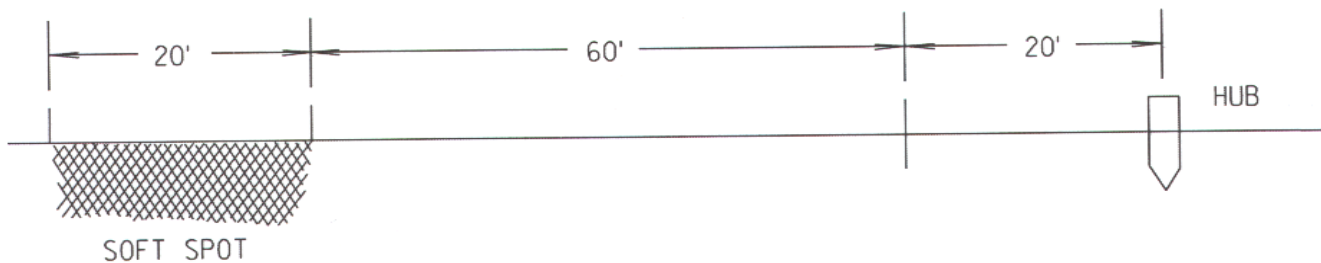

- The survey crew must know the length and width and the distance from the nearest hub.
- They will have the cross sections of the original ground and how much material was excavated.
- After the undercut there is a hole that has to be filled with BACKFILL.
- The materials that are used for backfill should not contain topsoil, sod, rock larger than 2 1/2", vegetable matter, material with too much moisture and bentonite.
- Gravel can be used to backfill, but something must be done to get rid of the water.

**Figure 7.5**

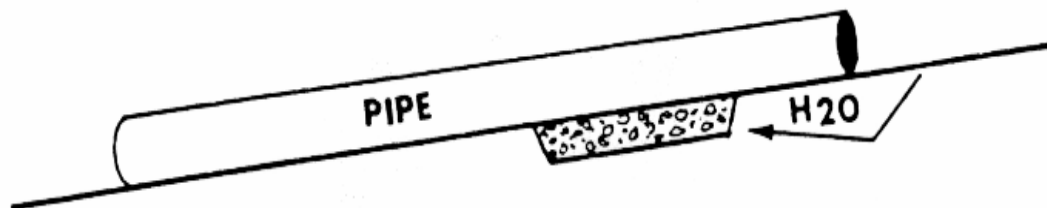

- Gravel has large spaces between particles and water can get in very easily. If water collects in the gravel under the pipe and freezes, it might push the pipe up.
- The illustration below is the best way to prevent water from being trapped in the gravel. The water can drain out.
- Always provide a method for gravel backfill to drain.

Figure 7.6



If the undercut is at the inlet end, gravel should not be used out to the inlet end of the pipe as the illustration below shows because water would flow into the gravel.

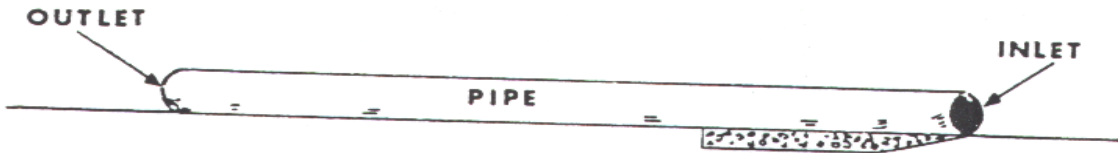

- Consult with the Project Engineer if a rock is encountered.
- A guideline that has been used for excavating rock and backfilling is one pipe diameter plus a 1'.
- The width of the excavation should extend 6" past each side of the pipe.

Remember rock should be excavated to a depth below the pipe of 1/2" per foot of fill over the pipe with a minimum depth of 12" and a maximum equal to 3/4 of the pipe diameter. The foundation below a pipe does have to "give" a little. This will cushion the pipe against the weight of the fill above it. Solid rock does not make a good foundation or cushion.

## CAMBER

Raising the center of the pipe to take care of settlement caused by the fill is called camber. How much camber should be put in depends on the height of the fill. The higher the fill, the greater the camber needed.

Here is an example using bricks and mud. In the first pile are two bricks, in the second pile, four bricks, and in the third pile, eight bricks.

Figure 7.7

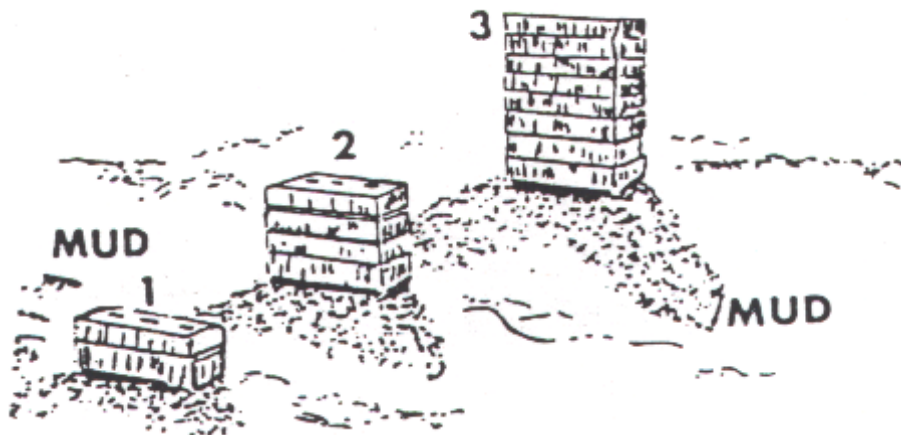

Pile # 3 will sink the furthest because of the additional weight.

Here is a cross section of a road with pipe underneath. Notice that the most weight is on the pipe in the center because there is more fill and weight there.

**Figure 7.8**

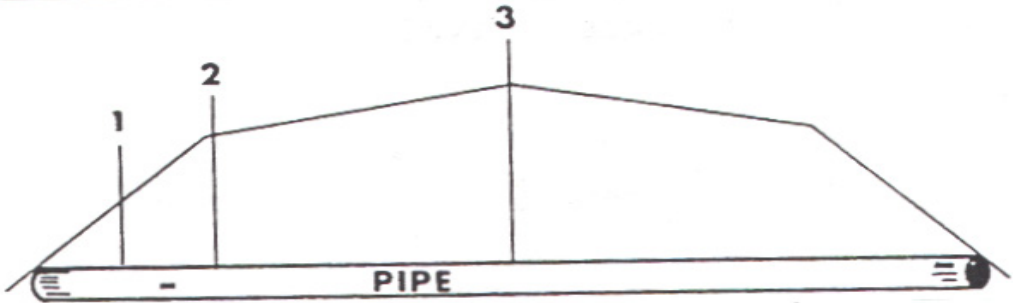

If a pipe, laid in a straight flat line, was put under an embankment and the center settled, it will look like the following illustration:

**Figure 7.9**

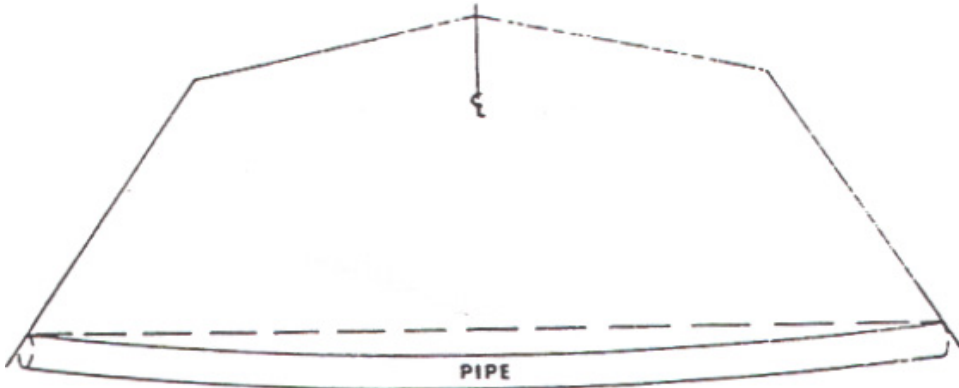

The center will settle the most because there is more fill and weight on the pipe there. This will cause the water to pond in the pipe. The bottom joints on RCP will open causing silting in the pipe. There is a way to take care of the settlement in the center of a pipe. Install the pipe with the center slightly higher like the illustration below:

**Figure 7.10**

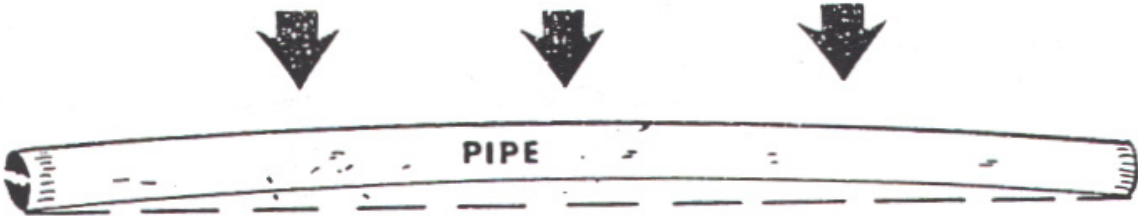

When fill is added it should push the center flat. See the example of an installed pipe below.

**Figure 7.11**

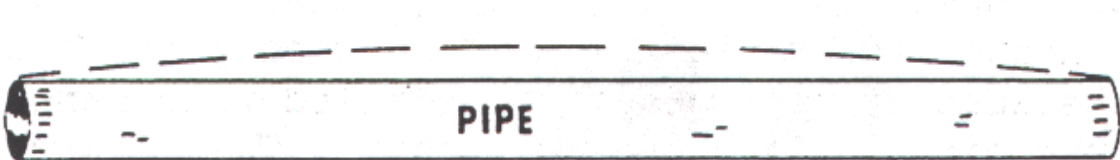

One thing that limits the amount of camber that can be put in a pipe is drop. Drop is the difference between inlet and outlet elevations. The middle of the pipe should not be raised higher than the inlet.

For the average pipe raise (camber), the flowline at the center of the pipe should be raised 2% of the fill height or 5 tenths whichever is greater. For example a pipe with 2' of drop and 40' of fill. 0.8' should be provided.

Most Contractors put in camber by setting up a stake at a given (usually 3' or 4') distance above the flowline at each end of the pipe. Then a string line is stretched between the stakes, one or more stakes are added in the middle of the pipe to support the string line.

**Figure 7.12**

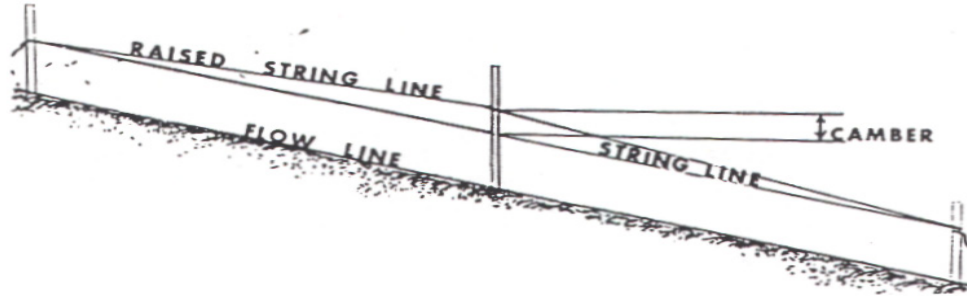

In actual practice, the Contractor will round off the grade so there is not a sharp break in the center.

**Figure 7.13**

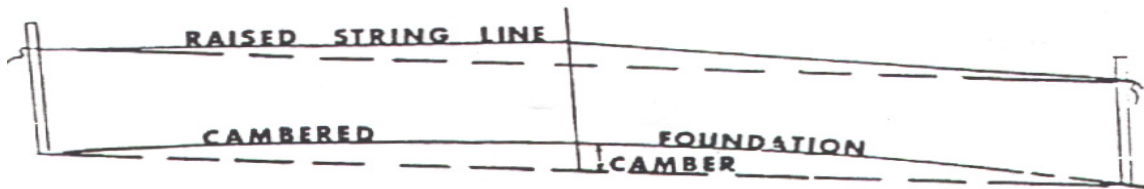

The Project Engineer should be consulted on the amount of camber for pipes in special conditions. The type of foundation constitutes a special condition. What is under the pipe is a factor, which determines if special condition is to be considered.

An example of a special condition is when there is an unequal foundation. An unequal foundation will occur when part of the pipe bed is undercut because of rock and is backfilled with sandy gravel and the rest of the pipe is laid on sandy clay.

Camber is installed differently under interstate highways. Camber is installed just like there were two separate pipes under two separate roads. Camber on an interstate should look like Figure 7.15.

**Figure 7.14 Incorrect**

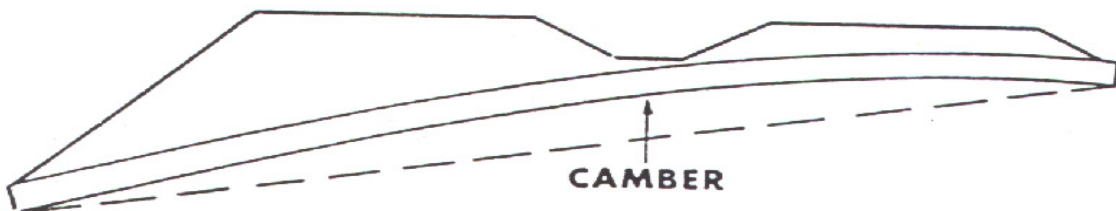
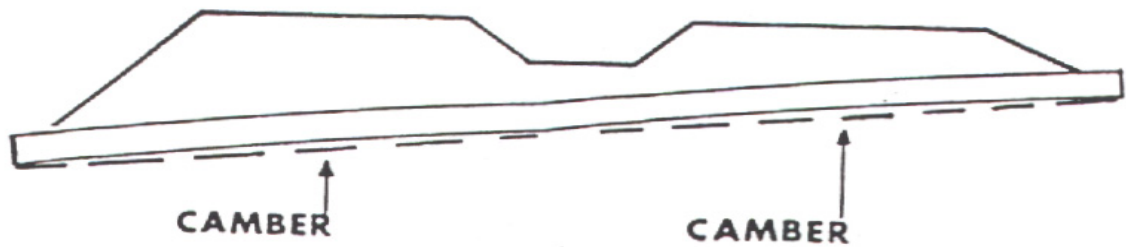

Figure 7.15 Correct



## BEDDING

---

The actual surface the pipe is laid on is the bedding.

There are three classes of bedding, Class A, Class B, and Class C. Class C should be used when no class is specified in the plans.

**CLASS C BEDDING:** is an earth or gravel/sand cradle of uniform density shaped to fit the lower part of the pipe for at least 10% of its overall outside height.

## CRADLE

---

Care must be taken when compacting soil under the haunches of a pipe. Too little compaction will leave voids. Too much compaction may cause the soil to act like a wedge and raise the pipe. The purpose of a cradle is to provide a firm, even support for the pipe.

Figure 7.16

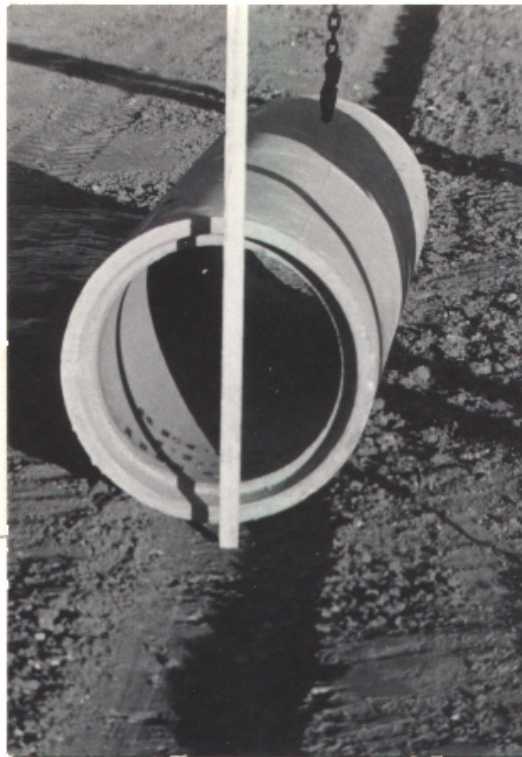

- The Contractor may cut this cradle by dragging or pushing a template attached to a motor grader or other equipment along the pipe foundation.

**Figure 7.17**

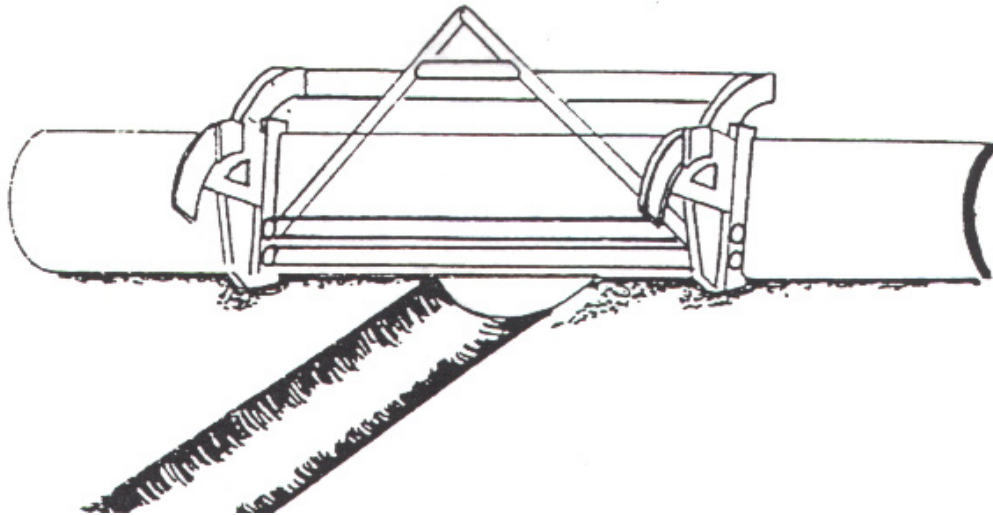

- The Contractor should have different cradles for the different pipe sizes so the cradle will match the pipe diameter.
- The Pipe Inspector should be sure that the Contractor has a cradle template for each size and type of pipe on the job.
- The depth of the cradle in Class C bedding should be at least 10% of the total height of the pipe.
- For RCP, the total height is the outside diameter (Rated Diameter + Pipe thickness).  
For CMP, the total height is the same as the inside diameter.

Example: Cradle depth for 36" CMP:  $36''/12 \times 0.10 = 0.30'$

Problem: Determine cradle depth of 60" RC pipe with 6" walls.

Answer: \_\_\_\_\_

When the cradle is cut in the foundation, the Contractor must consider the type and size of pipe and the depth of the cradle. The Contractor must place the pipe at the right elevation to meet the flowline. When a cradle is cut, the foundation must be higher than the flowline just enough to make the flowline of the pipe come at the right elevation.

**Figure 7.18**

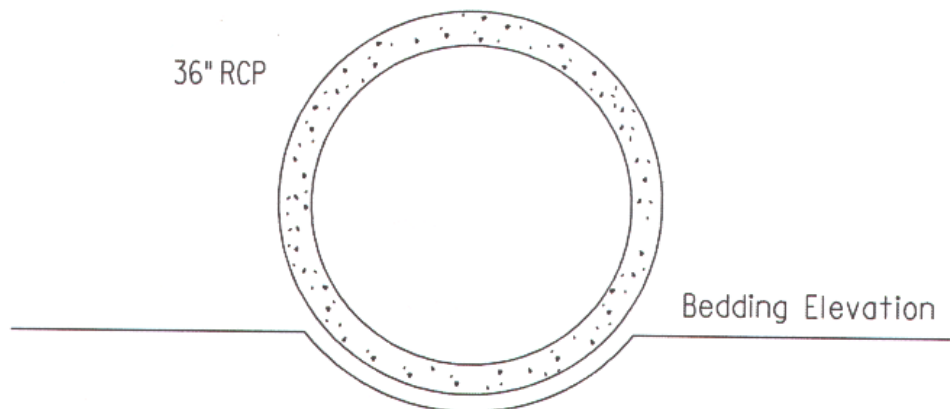

Assumed F.L. Elevation = 100.0

- Cradles are also required for arch pipe.
- The cradle should fit the pipe as close as possible.
- Gaps large enough to poke fingers into are too large.

**Figure 7.19**

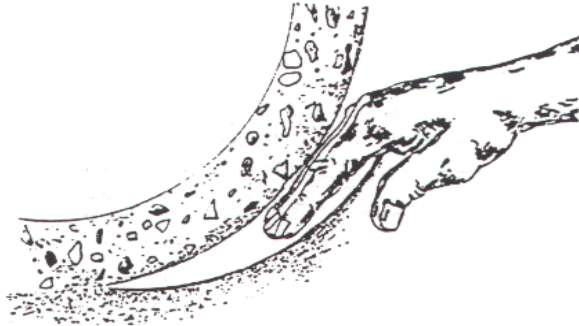

- No gap between cradle and pipe should be continuous.
- Cradles do not have to be cut for the end sections.
- Since end sections are not sitting in a cradle, the Contractor will have to tamp soil by hand or mechanical tampers under the end section.
- A flat bed is used to bed flared ends.

**Figure 7.20**

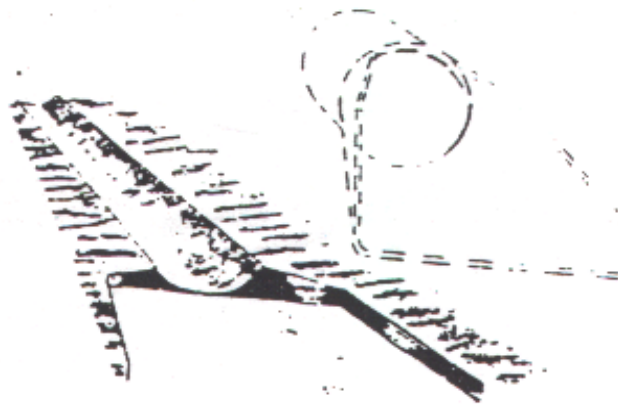

- Metal flared ends present a special problem. They have a lip that must be placed in the ground. A trench must be cut for the lip.

**Figure 7.21**

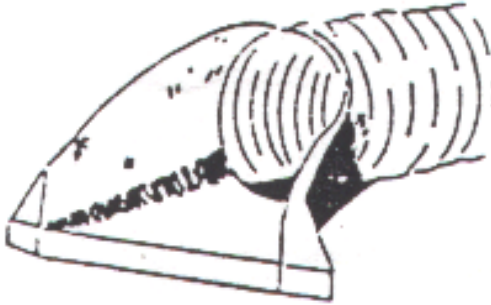

- Cradles must be straight.
- Check this with a string line stretched tight along the bottom of the cradle.
- If the cradle is crooked, the string will not be in the center of the cradle.

**CLASS A BEDDING:** Class A bedding consists of a continuous concrete cradle conforming to the plan details.

**Figure 7.22**



**CLASS B BEDDING:** Class B bedding is used most often for CMP.

- It provides more support for the pipe so it can be placed in higher fills.
- The ground under the pipe for Class B bedding must be excavated 1' wider than the pipe and 1' deeper and then back filled with the best material available.
- Six inches of undercut should extend past each side of the pipe.
- This is not required in new embankment, only in natural ground.

Problem: Determine the dimensions of the Class B installation shown below for a 24" CMP.



**Figure 7.23**

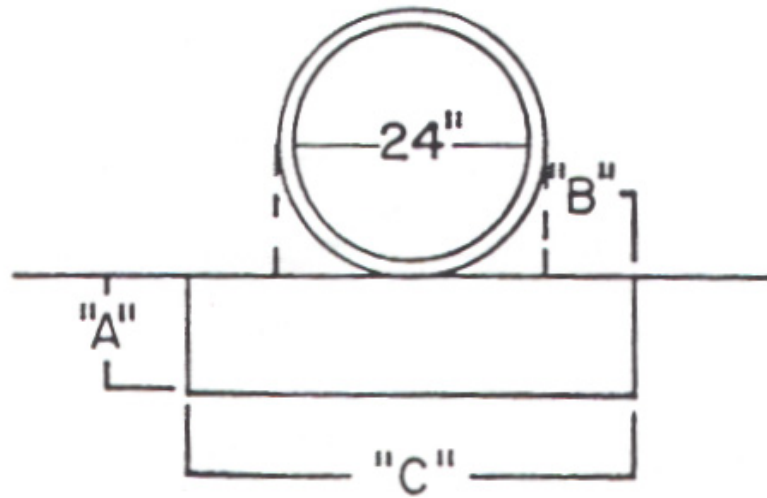

A = \_\_\_\_\_

B = \_\_\_\_\_

C = \_\_\_\_\_

The cradle for Class B bedding must have a minimum depth of 15% of the pipe height.

Example: The minimum cradle depth for a 24" CM Pipe is 0.3'

- In Class B bedding, the cradle is cut in suitable granular material. The sand must be at least 3" deep in the cradle.
- The next step in Class B bedding consists of mechanical tampers compacting soil in 6" loose lifts up to 30% of the pipe height.

Example: Using the 24" CM Pipe used in the previous example, 0.6' is how high the mechanical tamping is required from the lower face of the pipe.

The illustration below shows:

- No. 1 - Mechanical tamping in 6" lifts
- No. 2 - 15% of overall height of pipe cradles
- No. 3 - 3" layer of suitable granular material
- No. 4 - 1' wider than the pipe undercut and backfill.

**Figure 7.24**

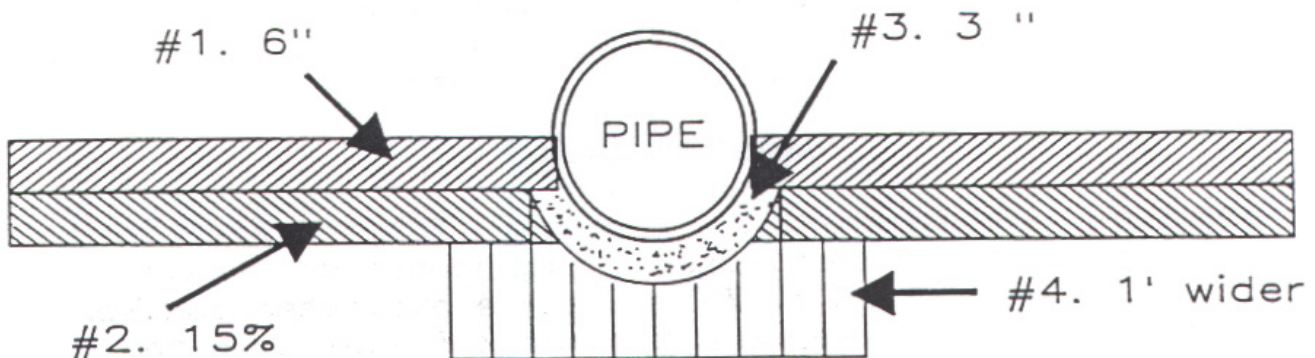

# PIPE PLACEMENT

---

## Concrete Pipe Culvert

- Concrete pipe culverts shall be laid with the groove or bell end of the pipe upstream and inserting the tongue end into the groove.
- The groove end should point upstream because it is less likely to let water out of the joints of a pipe when placed like the illustration below.

Figure 7.25

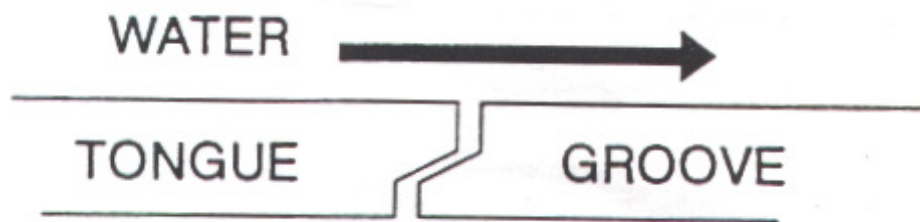

- Except where flexible watertight gaskets are used, the outside of each joint shall be covered with a 1' wide strip of drainage fabric around the perimeter of the pipe.
- The drainage fabric shall be centered over the joint.
- A construction adhesive will be required if the Contractor's method of installation doesn't secure the drainage fabric over the joint during backfilling operations.
- The purpose of the drainage fabric is to keep dirt, stones, etc., out of the joint.
- The lift holes shall be covered or plugged to prevent backfill from entering the pipe.

Corrugated metal pipe culverts

Figure 7.26



## Corrugated Metal Pipe

- Corrugated metal pipe culverts shall be laid with outside laps of joints pointing upstream. Most CM pipe supplied are made with a continuous locked seam, but some CM pipe can be riveted together as shown on Figure 7.27. If this style of CM pipe is supplied the longitudinal laps must be placed on the sides.
- Sections of CMP are bolted together with coupling bands.

Figure 7.27

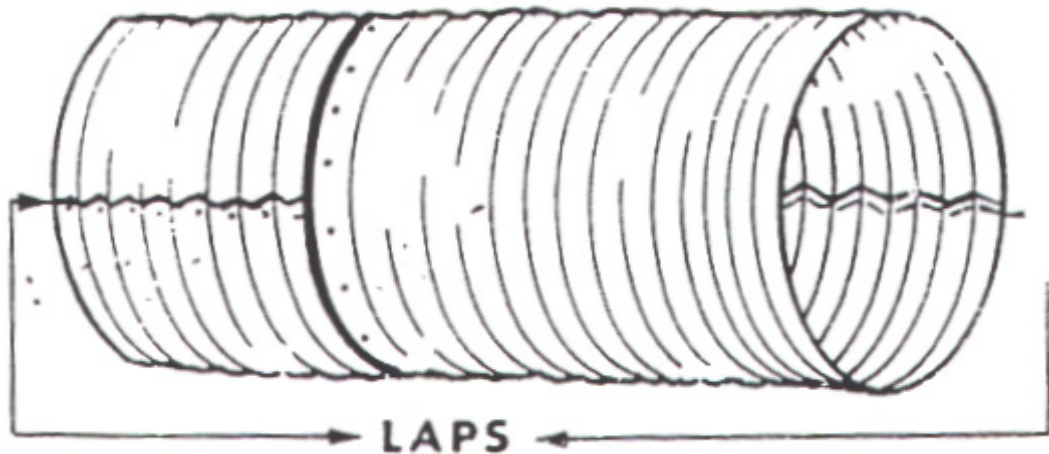

- The distance between each pipe must be adjusted so that the corrugations will mesh.

Figure 7.28

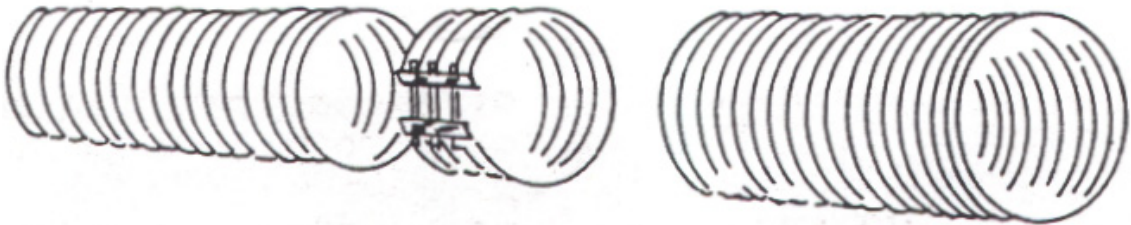

## BACKFILL

---

There are two types of backfill: Normal and Imperfect Trench.

- Each class of pipe has a limit to the amount of fill that it can hold. Refer to the Height of Cover Table for RCP in Appendix C. For example, a 24" RCP Class III will stand up to 14' of fill using Normal Type Backfill.
- However, there is a way to backfill over a pipe that puts less pressure on the pipe. The same class of pipe could be installed under a higher amount of fill, this method is called imperfect trench.
- Unless the plans call for imperfect trench, normal backfill will be used.
- Moisture and density requirements for backfill shall be as specified in the plans and shall meet the requirements of Section 120.
- Material used for backfill should be the best material available. It must be free of large lumps of sod, organic material, frozen material, or rocks larger than 2 1/2".
- For multiple pipe installation, refer to the plans for the backfill required between the pipes.
- In many instances flowable fill material will be specified.

## NORMAL TYPE BACKFILL

---

Selected embankment material shall be placed along the pipe in layers not exceeding 6" in depth and thoroughly compacted by mechanical compactors to the specified density before additional layers are placed.

- The width of the backfill on each side of the pipe shall be twice as wide as the external diameter of the pipe or 12', whichever is less.

Example: The width of backfill should be 7' or 84" on each side of 42" CMP and 12' on 84" CMP.

**Figure 7.29**

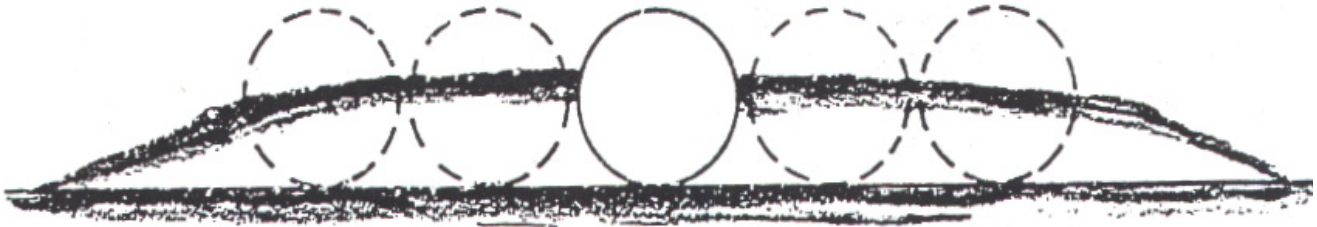

This method of pipe backfill shall continue until the embankment is at least 2' over the top of the pipe. The following illustration is a good example.

**Figure 7.30**

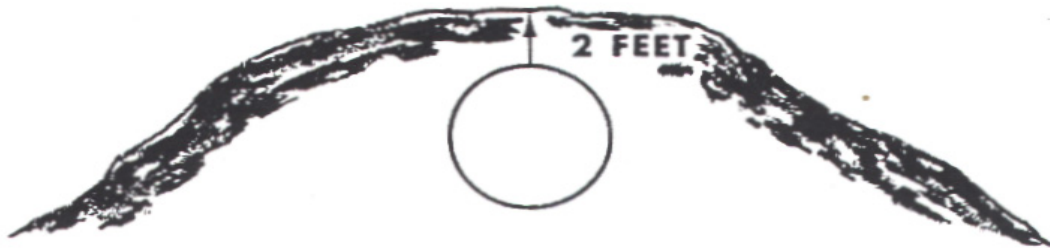

## IMPERFECT TRENCH

---

- Imperfect trench backfill is used on concrete pipe only.
- The pipe is installed, backfilled, and compacted by normal construction methods.
- Construct the fill to an elevation of at least one outside pipe diameter plus 1' over the top of the pipe.
- Compact on each side of the pipe for a lateral distance equal to twice the pipe diameter or 12', whichever is less.

**Figure 7.31**

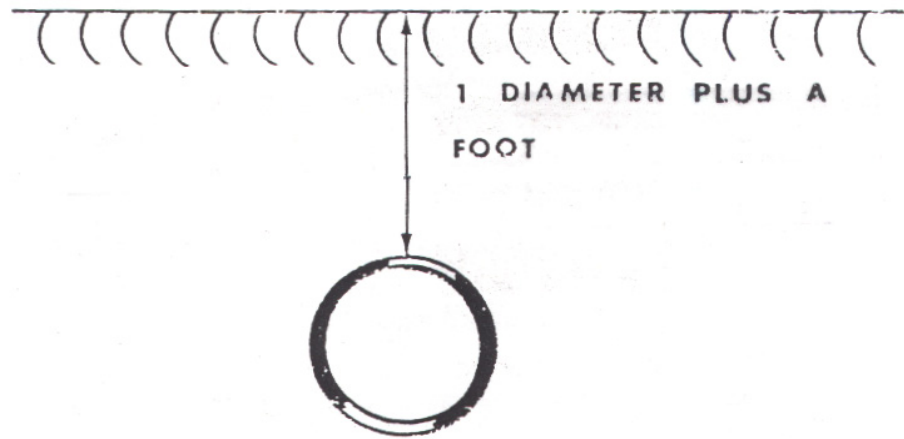

- A vertical trench is then excavated in the compacted fill directly over the pipe down to 1' from the top of the pipe.
- The width of the trench shall not be less than one outside diameter pipe diameter nor greater than one outside pipe diameter plus 8".

**Figure 7.32**

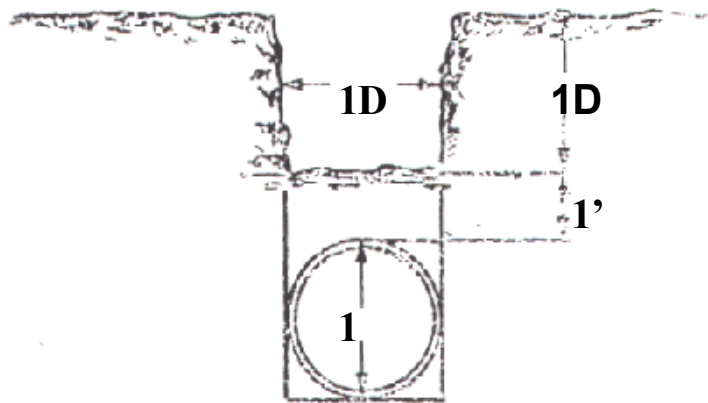

- Refill the trench with loose straw or sawdust to a depth of one outside pipe diameter.
- The straw and sawdust shall be reasonably dry and not decomposed or moldy.
- Other material shall not be substituted for imperfect trench backfill.
- Complete the remainder of the embankment from the top of the imperfect trench with normal fill material and normal embankment construction methods.

Problem: Determine the dimensions for A, B, C, and D assuming a 60" RCP:

**Figure 7.33**

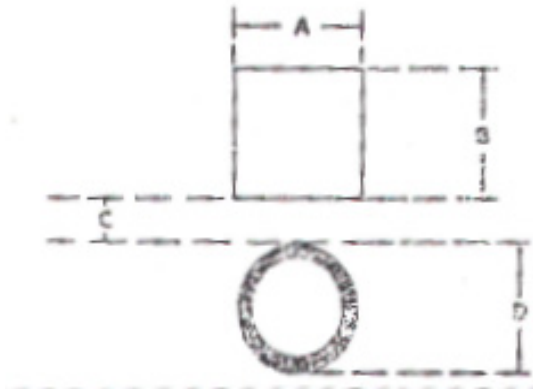

- A - \_\_\_\_\_
- B - \_\_\_\_\_
- C - \_\_\_\_\_
- D - \_\_\_\_\_

Imperfect trench should always be run from one shoulder to the other as a minimum. A and D mark the maximum amount of cover allowed over the pipe without trench backfill. B and C mark the shoulders. Imperfect trench should be used from A to D.

**Figure 7.34**

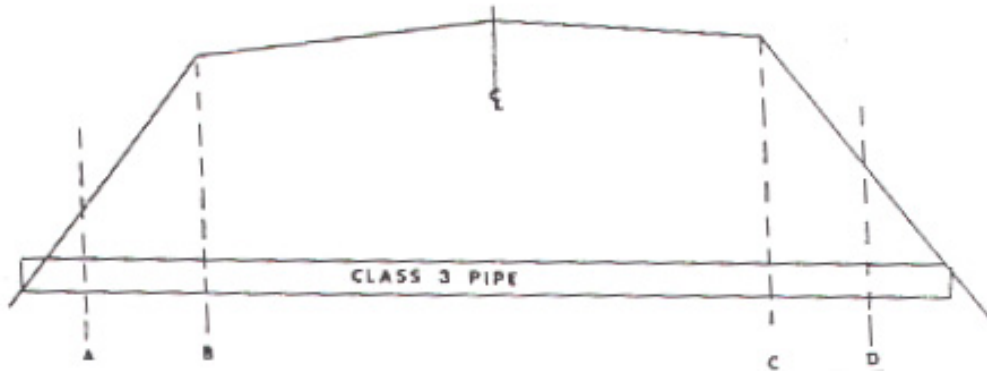

On the following example the dotted lines enclose the area of fill greater than allowable without imperfect trench. The solid lines show the shoulders. Imperfect trench should extend from B to H.

**Figure 7.35**



Imperfect trench should begin and end where there is a maximum allowable fill for normal backfill. It should never be less than from shoulder to shoulder.

# TRENCH INSTALLATION

---

Sometimes (usually in city installations) pipe will be installed in a trench condition.

**Figure 7.36**



- There are two factors in trench design that determine how much load there will be on the pipe:
  - The walls should be as vertical as possible.
- The trench should be as narrow as practical.
- The trench should be just wide enough to permit earth to be compacted under the haunches.

This cross section of trench installation is poor because the trench is too wide.

**Figure 7.37**

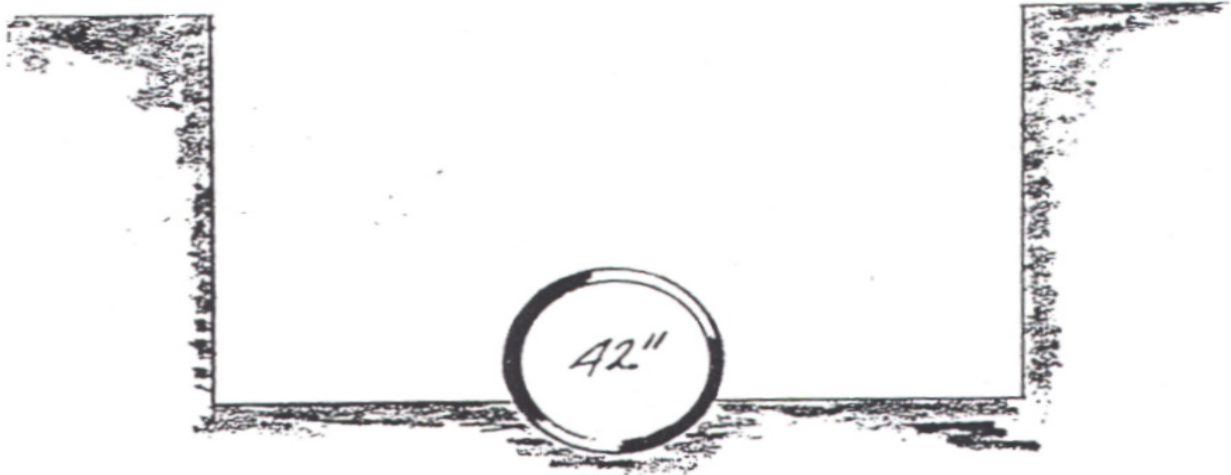

The cross section below is poor because the trench is too narrow.

**Figure 7.38**

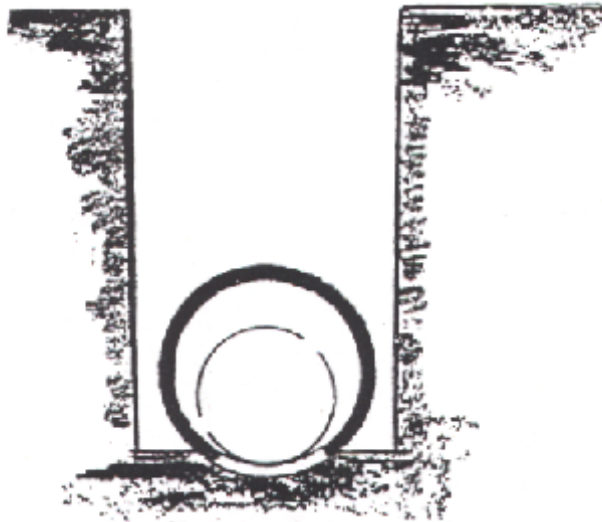

The following cross section shows that the trench is not vertical.



**Figure 7.39**

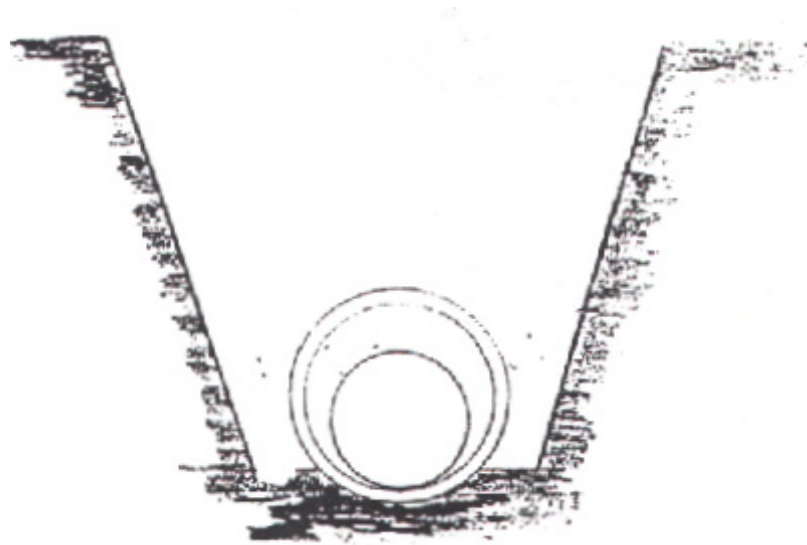

For practical purposes the trench should be at least 1' wider than the pipe on each side of the pipe.

The pipe must be cradled. The Contractor can form the cradle in sand. Just about any sand is O.K. but concrete sand (Passing a 3/8 sieve) is best. Course sand and gravel will need mechanical compaction. The finer sand will compact by adding water.

There are two common methods used to check the elevation of the bed. The pipe is staked every 25' to 50'. The offset will vary as needed to keep the stakes away from the construction. Cut is staked to .01 of a foot.

- One method is to check the elevation of the bed with a level or hand level.
  - The Contractor will also set up a string line in the trench at a given elevation.
  - That elevation is marked off on the shovel handles to check progress.
  - The foundation is cut to flowline and fine-graded in natural ground to flowline plus pipe wall thickness.
- Another method commonly used is a pipe laser.
  - The first pipe is usually set to grade using a rod and level.
  - The laser is set in this pipe with the slope of the pipe dialed into the laser.
  - A laser beam is projected through the pipe and the alignment and grade is determined from the beam.
- This type of stake will be found on trench installation.

**Figure 7.40**

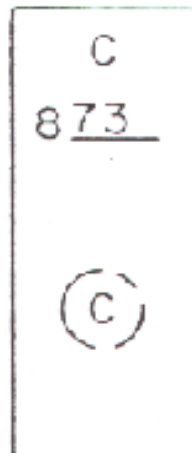

- Pipes in trenches are staked to .01 and fill stakes are unlikely in trench installations.
- Part of the inspector's job involves checking the accuracy of the flowline.
- This is done by one of the following methods using a level.
  - Sight with a rod held on the flowline.
  - A rod held on the top of the pipe and added to pipe diameter plus one wall thickness.

**Figure 7.41**

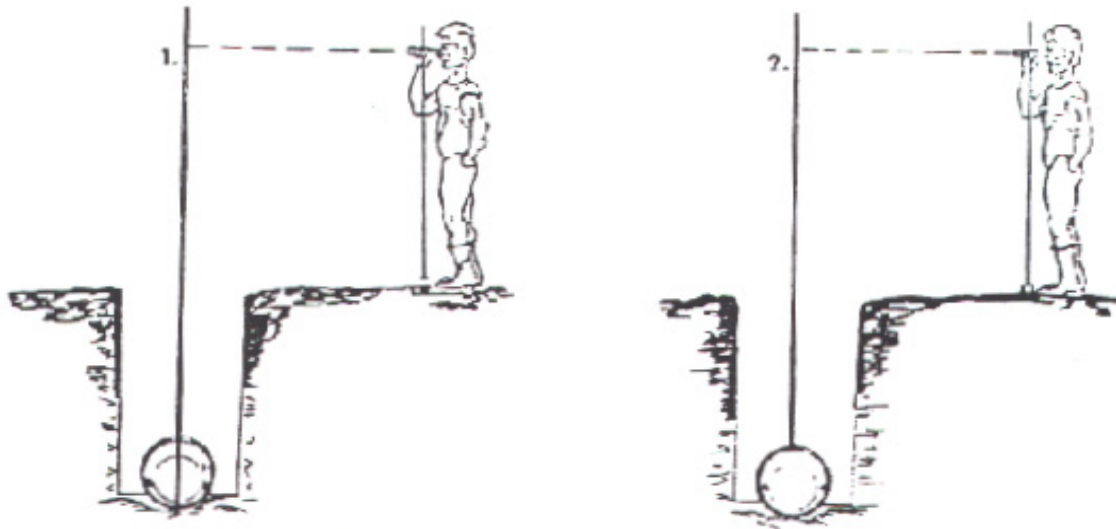

Be sure that the earth is well tamped under the haunches when installing pipe in trenches.

Figure 7.42

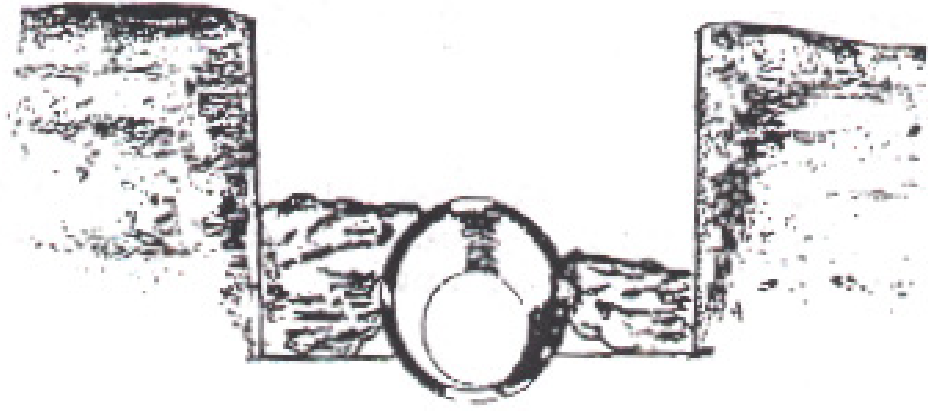

## FIELD TESTING

During pipe installation, field tests must be performed on the undercut and the backfill to insure that the roadway above the pipe will be uniform and provide a stable foundation for the base course and surfacing.

All tests must be performed by a certified tester.

The three basic tests involved in earthwork construction are:

- Moisture Tests
- Density Tests
- Moisture - Density Tests (commonly referred to as a "Proctor")

Moisture tests are performed to determine the amount of water in a given sample of material. The moisture content is expressed as a percent of the material's dry weight. The weight of the water divided by the weight of the dry sample times 100.  $[(\text{wet-dry})/\text{dry}] \times 100$ . (DOT - 35)

Density tests are performed in the field on material after it has been compacted. The density is expressed in pounds per cubic foot (DOT - 41)

Moisture - Density tests (Proctors) are used to determine the optimum moisture content (the amount of water necessary to compact the soil in the field) and the resulting dry unit weight of material which can be expected from compaction at this optimum water content. (DOT - 41)

- It is the responsibility of the Inspector to know how to perform the various tests correctly and how to interpret the results once the testing has been accomplished.
- The tests listed above will, in many cases, be the deciding factor in questions arising about the acceptability of the work performed.
- Samples taken and tests made will be in accordance with the most recent South Dakota Department of Transportation Materials Manual - Sampling and Testing Procedures, including revisions or additions which are current on the date of advertisement for bids.

Pipe lift embankment testing

- 24" ROUND or less (30" ARCH): 1 test in backfill 1/2 way up the pipe and 1 test in the 2' of backfill above the pipe.
- 30" to 72" ROUND (36" to 84" ARCH): 1 test 1/2 way up the pipe, 1 test in upper 1/2 of pipe, and 1 test in 2' of backfill above pipe.

- 72" ROUND and larger (96" ARCH): 1 test in bottom 1/3, 1 test in middle 1/3, 1 test in upper 1/3, and 1 test in 2' backfill above pipe.
- After minimum test, 1 test per installation per 3' of backfill starting above the 2' above the pipe up to the elevation where normal grading operations commence.

## **TEST LOCATIONS**

---

Refer to Material Manual for requirements of Pipe density tests.

Problems:

Determine the number of density tests required at the following locations:

Sta. 326 + 00

Sta. 385 + 00

Sta. 396 + 90

36 + 63.86 Lt. to 36+61.30 Rt.

Assume Rt. Pipe placed in spring and

34+36.00 to 39+47.27

## UNDERDRAINS

Underdrains are not an everyday occurrence. It must be dealt with when subsurface water is present. An example of this would be a road that passes over a spring or when the water table is very close to the surface. Special pipe, usually 4" to 12" in diameter is used. There are perforations usually about 1/3 of the way up the pipe.

Subsurface drains, or underdrains, is placed below the surface of the roadway to collect and drain the water that may accumulate. This water may be coming either from below or passing through the subgrade.

These underdrains are usually trenches containing porous material and a perforated pipe to collect the water. The water is carried through the pipe to a place outside the subgrade.

The plans will contain information regarding the location, depth, pipe, and backfill materials to be used.

The trench to receive the pipe and porous backfill is excavated to the width and depth shown on the plans or as directed by the Project Engineer. Surplus excavation is disposed of at a place specified by the Project Engineer.

A survey crew must take cross sections of the area before and after the excavation. These measurements are taken to document the quantities of materials removed.

After the excavation is completed, a layer of porous material is placed at the bottom of the trench. A tarpaulin or some other approved device should be used at the edge of the trench to prevent the contamination of the backfill material. Avoid getting dirt in the ditch.

The drainage pipe is placed on the top of the layer of porous backfill. The holes in the pipe must be on the lower side, except in the outlet section where leakage would result, rather than infiltration. The sections must be well "bedded" (intimate contact with the base) for its entire length and bolted or banded together as designed.

Additional porous backfill material is placed in the trench. As soon as the pipe is laid, no compaction is required, but the height of the fill should be kept level at all times. Do not have more cover on one end than the other. This may cause shifting of the pipe. The ends of the pipe may be open. Be careful to see that dirt or backfill material does not get inside the pipe. The entire trench should be backfilled with the specified material.

Check the plans for complete details on each installation. Perforations on the pipe are placed down in the trench to collect the water. A non-perforated pipe may be used, for the end sections.

# 10

## REJECTION

Not all pipe is perfect by the time it gets on the job. Many things can happen to make a pipe less than perfect. First, look at RCP. If a pipe were dropped from the truck onto hard ground, it might crack the pipe. Not all cracks are serious. Some cracks do not seriously affect the strength of the pipe. The problem is to tell the difference.

- There is one way to find pipe with cracks.
  - Tap the cracked pipe with a hammer.
  - Pipes with serious cracks have a different sound.
  - If a crack in a pipe is serious, it will probably cause the pipe to sound dull when tapped.
- When a pipe is seriously damaged, reject it.
- Reject the pipe if you see a pipe with a crack that runs clear through the barrel for the full length of the pipe.
- Cracks in the tongue or groove are treated differently if it does not extend into the pipe. It should be rejected if the damage would prevent a good seal.
- Pipe with exposed reinforcing steel should be rejected although it may be repaired if the damage is not too great with grout (a sand-cement mixture).

The following illustrations are pictures of damaged pipe.

The following pipe is rejected because the damage runs clear through the barrel for the full length.

**Figure 10.1**

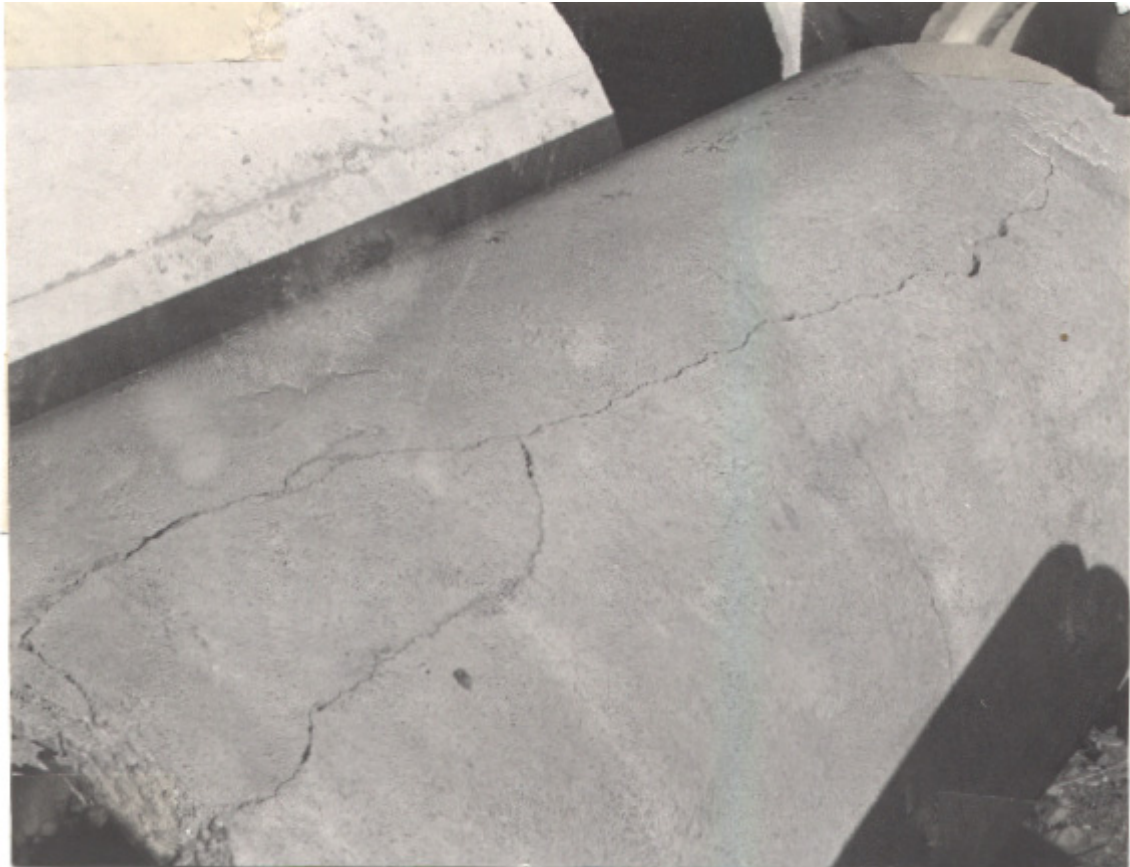

Here is a shot of an 84" pipe taken from the inside. The cracks do extend through the pipe. This pipe does not produce a clear ring when tapped with a hammer like other pipe of the same size. This pipe should be rejected.



**Figure 10.2**

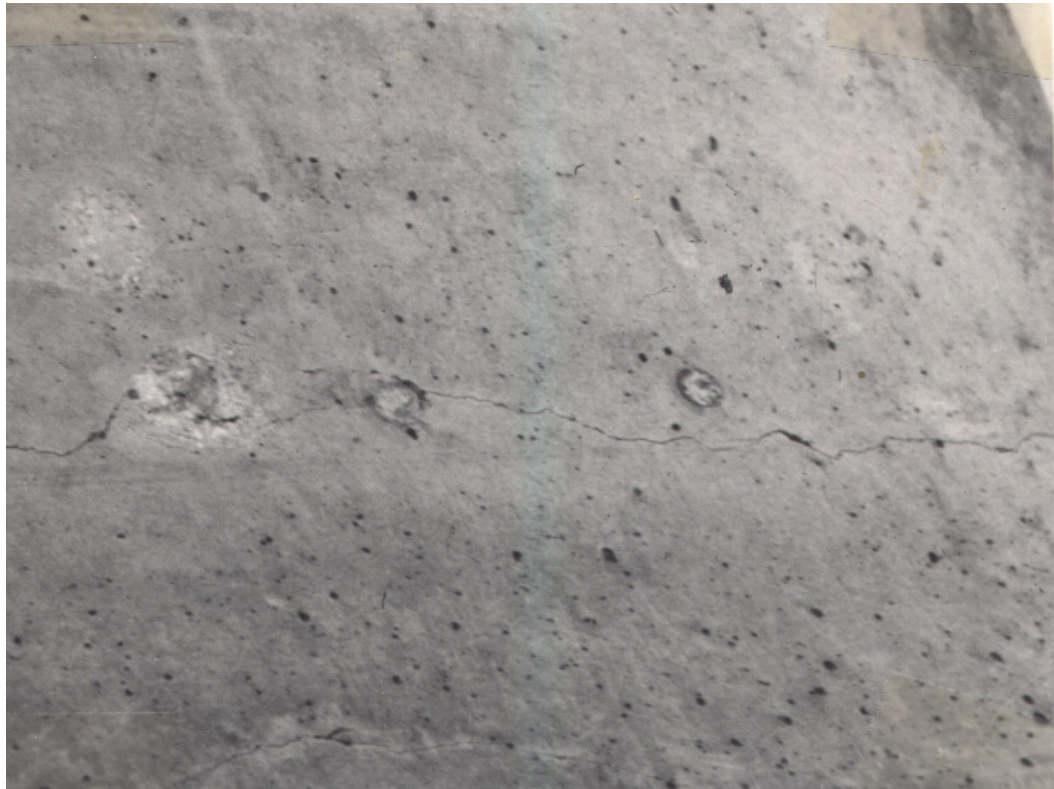

This picture is a close up of the wall of a cattle pass. When struck with a hammer, this sections produces a dead thud type of sound. Reject this pipe because there is a crack in the wall of the pipe.

**Figure 10.3**



If a crack in a pipe is wide, water may collect in it and freeze. If the crack were sealed with grout, water could not get in. Here is a close up of a 30" pipe on the tongue end.

The crack, while it is wide, is only about 1/4" deep. The pipe gives off a clear ring when struck. The pipe should be rejected, however, repair is allowed.

**Figure 10.4**



Honeycombing is an area where most of the cement and water leaked out during manufacturing leaving voids between the aggregate. Here is a close up of the female end of a pipe. The pipe should be rejected, however, repair is allowed.

**Figure 10.5**



Repairs must be properly done and should make the pipe "as good as new." Grout must be strong and cured properly. In the following illustration, repairs have been attempted, however it did not cure properly and the pipe has to be rejected.

**Figure 10.6**



The following is an example of a flared end that has honeycomb damage. It should be rejected because of the large area that is honeycombed.

**Figure 10.7**

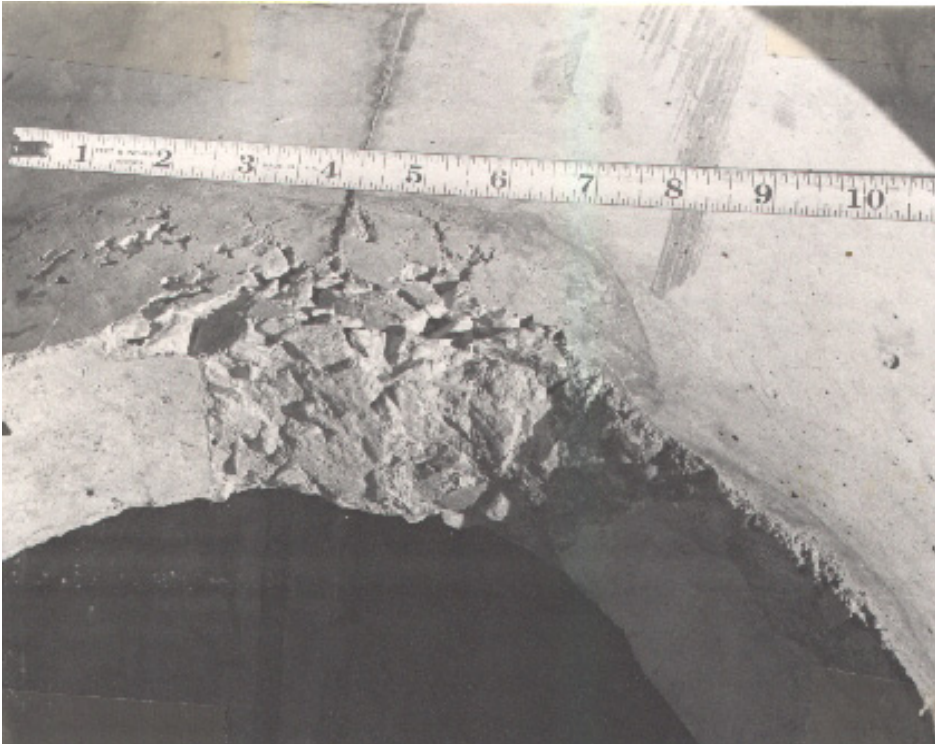

When there is damage to a pipe that exposes reinforcing steel, it should be rejected. The Contractor may attempt repair. Be sure to inspect it again. The following illustration is an example of a damaged male end of an arch pipe, which should be rejected but could be repaired.

**Figure 10.8**



The following pipe is rejected because it is honeycombing; however, it could be repaired and inspected again.

**Figure 10.9**

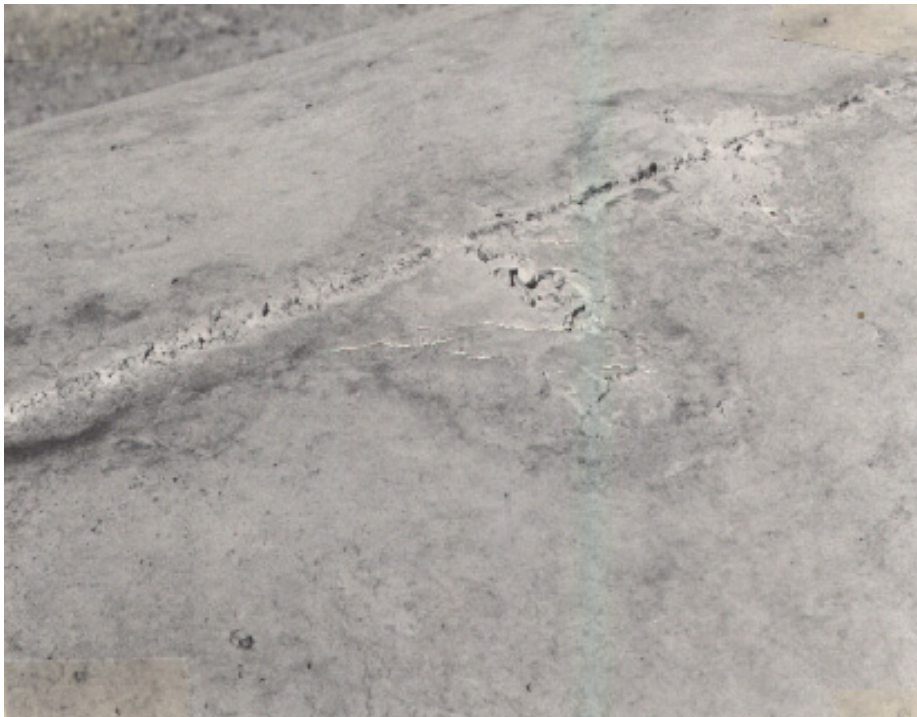

Rejection of this pipe is for exposed reinforcing steel. It probably could be repaired by the pipe company, but not by the Contractor.

**Figure 10.10**



The following pipe is rejected because of a wide crack. It can be repaired if filled with grout to seal the crack and it must be inspected again.

**Figure 10.11**

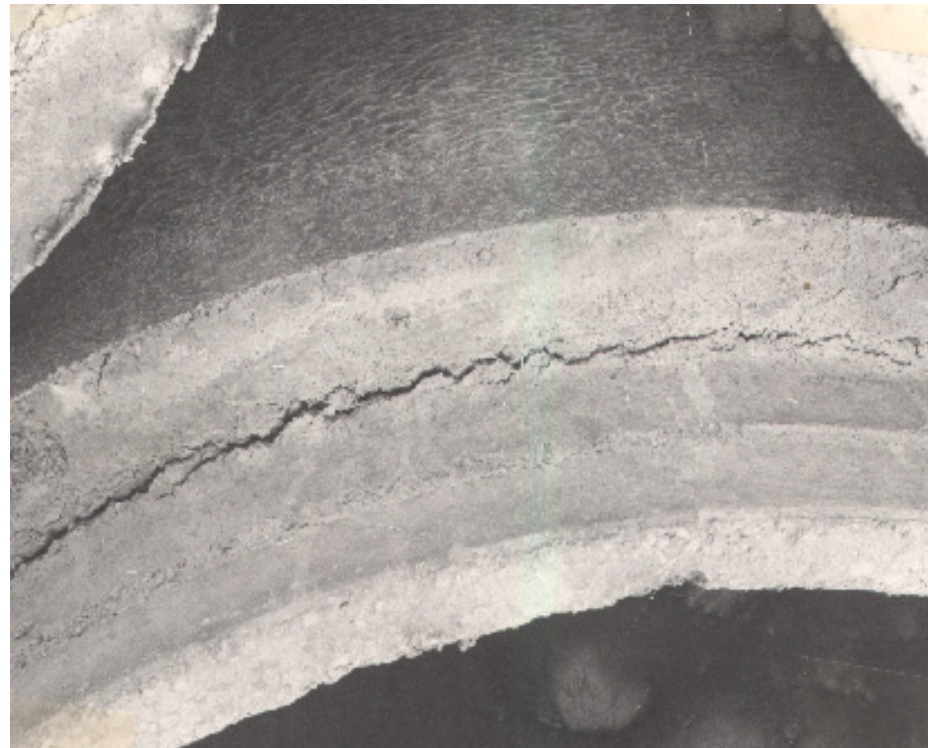

Rejection of this is for exposed reinforcing steel. It can be repaired and inspected again.

**Figure 10.12**



This is a close up of the side of a 48" RCP, Rejection is for exposed reinforcing steel. It can be repaired by a simple patch job with grout.

**Figure 10.13**



Rejection: As per AASHTO specifications, a pipe that has sustained damage that is not repairable should be set aside with no marking on the pipe. A colored "Lumber Crayon" may be used to indicate and "R" or other marking on pipe that is not acceptable for use on the project. If a pipe that has been previously rejected and is repaired, inspect that pipe carefully. Make sure the grout has cured properly and does not show shrinkage cracks or flake-off because of poor bond or curing.

## RC PIPE

---

Inside every concrete pipe there is a stencil that tells the date the pipe was manufactured, the class of pipe, manufacturers trademark, and plant location. For example, a stencil that looked like this:

WALL B  
CRETEX  
C4 RC 6-2-99

It will contain all the information, and occasionally the wall design. The trademark would be cretex, class IV, date 6/2/99 and plant location, Rapid City.

- Occasionally the stencil may be missing or unreadable. They should be rejected.

Pipe that have a readable class (i.e. Class III and IV, etc.) can be accepted on the basis of a Swiss Hammer Test. Class III and IV should test at 4,000 psi and Class V at 6,000 psi. If there was a pipe with only a class number, call the Project Engineer and have him check the pipe with a Swiss Hammer.

- Reject the pipe when only the date or manufacture is readable.

## CMP (CORRUGATED METAL PIPE)

---

Heat numbers are numbers that are stamped into, stenciled or painted on sheet metal that is used to make CMP. They serve as kind of serial number for the steel. Each batch of sheet steel is sampled and tested, then given a heat number.

- When CMP arrives on the job, it comes with a list of heat numbers that the manufacturer certifies meet the state's requirements.
- The heat numbers on that Certificate of Compliance should match the heat numbers on the pipe.
- A Certificate of Compliance is not required if the pipe is on the "Approved Products List".
- If you cannot read the heat numbers on the pipe or if they are the wrong heat numbers, reject the pipe.
- All the other reasons for rejecting CMP have to do with the condition of the pipe itself.
- CMP has a coating of zinc to protect steel from rust.
  - If that coating were gone in a certain spot, the pipe would probably rust there.
- If a pipe comes with the smelter coat damaged, the damaged area should be painted with a zinc paint or it should be rejected.
  - This also applies to the ends of the pipe.
- As far as damage or poor workmanship is concerned, common sense will dictate whether to reject the pipe or not.
- Loose or missing rivets, large dents, or pipe bent out of round are examples.

Hint: Some inspectors check pipes as soon as they come on the job. They mark each pipe they have inspected with a small dab of paint to show that they have been inspected.

# 11

## FINAL INSPECTION

After a pipe has been bedded, backfilled, and the subbase has been built up to grade, inspect it for damage.

- The pipe may have been damaged when machines were building above it.
- A large crack in the pipe is a good sign that concrete pipe has failed.
- Also too much pressure on CMP would buckle or cave it in and the Contractor would be required to replace it.
- The joints might open up if the center of the pipe settled more than you expected (RCP).
  - This might let water flow under the pipe instead of through it.
- When a section of RCP is found to be broken or defective, it must be replaced. Do not allow the Contractor to replace this pipe with a section that has all or part of the tongue or groove broken off.
- If a section of RCP in the middle of the pipe is cracked, have it replaced.
  - If there is not enough compaction, the sides will push out and the top of the pipe will cave in under high fills.
  - If the fill is too high or the pipe is too weak, the pipe will fail.

This illustration shows the probable cause for the failure if it is a deflection - too little compaction on the sides, yield buckle - fill too high for that gauge of CMP, elastic buckling - fill too high for that CMP and seam stress - rivet failure.

**Figure 11.1**

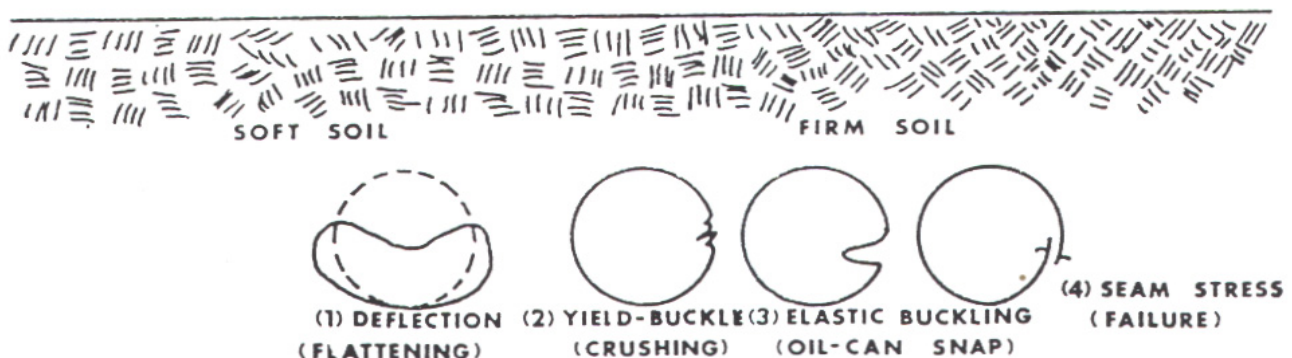



## PIPE SPECIFICATION REFERENCES

The next section is designed to provide you with a quick reference of formulas and guidelines.

- Class C bedding requires that the pipe be cradled for at least 10% of its overall height.
- Class B bedding must be cradled for at least 15% of its overall height and undercut 1' deep and 1' wider than the pipe, except in new embankment. Mechanical tamping must be taken another 15% of the pipe's height above the cradle.
- Camber is calculated at 2% of the height of the fill or 5 tenths, whichever is greater.
- Normal backfill and backfill in trenches should be taken 2' above the pipe.
- Refer to the specifications for the number of tests required for the size of pipe.
- The guideline for undercut in rock is 1/2" per foot of fill over the pipe with a minimum of 12" and a maximum of 3/4 of the pipe diameter.

## PRECAST CONCRETE BOX CULVERTS AND LARGE PIPE OR ARCHES

### FABRICATION

---

Precast box culverts and large pipes or arches are usually cast in the fabrication yard of a precast concrete product supplier. The Contractor will need to supply the Bridge Design Office a set of shop drawings (or shop plans) and a copy of design computations for review and approval at least thirty (30) days prior to start of fabrication. Shop Drawings are working plans that function as the following:

- They specially detail how the supplier will construct or fabricate the precast units; and
- They function as additional construction plans that provide erection or placement sequencing as well as additional specific required details.

### INITIAL FIELD INSPECTION

---

When the precast box culvert or pipe pieces are delivered to the site, they need to be checked for damage that may have resulted from storage or shipment. Specific items to look for are:

- Cracks - Small hairline cracks need not to be a concern, however, larger cracks are indication that the precast piece has been mishandled and may be structurally compromised.
- Pieces Broken Off - Indicates that the piece may have been dropped, collided with, or that it collided with another object in handling.
- Bent Reinforcing Dowels - Occasionally a precast piece will have embedded dowels protruding from one of its faces in order to connect it to cast-in-place concrete. Check to see that the dowels are straight, and that they are firmly embedded and not loose.

If you find any damage, contact the Project Engineer or Engineering Supervisor. Major damage should also be brought to the attention of the Bridge Design Office prior to allowing the piece to be installed.

**Figure 13.1**



Check all materials for cracks, pieces broken off, and bent reinforcing dowels.

## **BEDDING**

---

Like cast-in-place box culverts, precast culverts and pipes need to be placed on a stable foundation that is constructed through undercut and backfill operations.

- The bedding must provide uniform support along the full length of the pipe or culvert barrel to evenly distribute the bearing reaction.
- For precast culverts, the bedding section is a flat section similar to what is used in cast-in-place box culverts.
- For precast pipes and arches, the bedding is in the shape of a *cradle* that matches the bottom shape of the precast section.
- The bedding cradle should conform to one of three specified classes as follows:
  - Class A Bedding - This bedding must be a continuous concrete cradle that conforms to specific plan details.
  - Class B Bedding - This bedding consists of excavating a minimum of 12" below the bottom of the pipe and a width equal to the exterior diameter plus 1'. Following that, select fill material is placed and thoroughly compacted to a height at least equal to 15% of the pipe height above flow line. Following compaction, a cradle shape is cut out of the back fill. The pipe is then laid on a minimum 3" granular material over the shaped backfill cradle.
  - Class C Bedding - This bedding consists of an earth or gravel cradle that is shaped to fit the lower portion of the pipe for at least 10% of its overall height.
- Plans should specifically note what type of bedding is required for the precast pipe or arches.
- If it is not noted, then Class C bedding should be assumed.
- Note also that for large pipe and arches, the Class C Bedding is generally constructed with granular material rather than earth fill.
- The bedding is typically the top 2" of backfill as shown in plan sheets.
- Section 421 of the Specifications provides the requirements for Backfill Material.

- Always check the plan sheets as they may require a different gradation than indicated in the Specifications.
- If heavy equipment operates on top of the bedding, the resulting compaction caused by the equipment shall not be greater than that of the bedding at any other location.
- Refer to the Materials Manual (M.S.T.R.) for testing requirements:
  - 3.11 granular box culvert undercut backfill
  - 3.12 miscellaneous granular materials (pit-run/box culvert bedding/etc.) when specifications are noted.

## **INSTALLATION**

---

- Precast sections should always be laid with the groove end upstream, starting at the lowest elevation (or outlet) of the culvert.
- Sections can be installed with internal joining devices.
- An anchor beam is positioned inside several precast sections behind the section that is being installed.
- A timber beam is positioned across the exposed joint of the section to be installed.
- The timber beam and anchor are connected with a jacking system that permits the section to be "jacked" into position.
- Installation goes easier when all tension is released from the lifting line.
- Occasionally Contractor's will try to use heavy equipment to "push" sections into position.
- Excavating equipment such as back hoes or loaders without modifications should not be used, as they can damage the joints of the precast sections.
- In some cases the Contractor can outfit a loader with a tongue attachment rather than the bucket.
- If this is the case, the tongue should be wrapped with carpet or other means to ensure that damage does not occur to the precast units.
- In addition, when placing sections with heavy equipment, you should pay special attention to the condition of the backfill and cradle during placement operations.
- Watch to ensure that rutting or depressions are not created that would prevent the precast section from resting evenly on the backfill.

## **JOINTS**

---

- The joints of precast sections are typically fastened together with special devices called joint ties or tie-bolts.
- The tie bolts help to hold or clamp the sections together in order to help prevent movement during back fill operations.
- They are not, however, adequate to act as a shear transfer between sections.
- It is critical that the joints between sections are brought together to become as tight fitting as possible during installation operations.
- Following installation of the sections, and prior to back filling, all joints of the precast sections receive special treatment similar to that of joints in cast-in-place box culverts.

- The floor joint between adjacent sections should be sealed with performed mastic to a point 1' above the flow line. A strip of 2'-6" wide drainage fabric is then wrapped around the top and down the sides.
- In addition, the lift holes are plugged with an approved nonshrink grout.

## **STRUCTURE EXCAVATION, BOX CULVERT**

---

- When a box culvert is constructed at or above the specified flow line, the plan shown quantity of structure excavation will be the pay quantity.
- This quantity of excavation is equal to the theoretical volume of concrete below the flow line.
- When the engineer orders the flow line lowered on construction, the material excavated between the plan shown flow line and the constructed flow line will be measured for payment as unclassified excavation unless it is unstable material and must be removed by a dragline, backhoe, or similar equipment in which case it will be measured as structure excavation.
- Document this additional excavation in field notes.

## **UNDERCUTTING CONCRETE BOX CULVERT**

---

- This work consists of the removal of unstable material below the bedding grade of the box culvert and the backfill of undercut areas.
- The plan sheets will show the Limits of the Undercut.
- When additional undercut is required, it will be paid for at the contract unit price for Undercutting, Box Culvert.
  - Document the additional excavation in field notes.
- Section 421 of the Specifications provide for requirements for Backfill Material.
- Always check the plan sheets as they may require different gradation than indicated in the Specifications.
- Backfill shall be satisfactorily compacted in horizontal layers not to exceed 6" loose depth.
- Refer to the Materials Manual for testing requirements:
  - 3.11 granular box culvert undercut backfill
  - 3.12 miscellaneous granular materials (pit-run/box culvert bedding/ etc.) when specifications are noted.

## **HANDLING**

---

- The Contractor shall exercise care when handling box sections.
- The sections are very heavy and may be damaged if not properly handled.
- The Contractor shall provide a soft landing area for laying and tipping box sections.

# INSTALLATION SEQUENCE

---

- Set first section of the outlet end first.
- Place joint sealant on the floor of the female end (in the middle) from top of haunch to top of haunch.
- Dig a groove approximately 1" deep and 2" to 3" wide in front of the female joint for the entire width of the bed so bedding material does not push into the joint.
- Prior to setting each section use the screed to reshape the bed and remove the material from the groove.
- Use pulling bracket and come-along system to pull the joints together.
- Check the joint gap.
  - If the gap is larger than 3/4", pull the joint apart and check for obstructions and check flatness of bedding surface.
  - This maximum gap does not apply to the center wall of double cell boxes.
- Install tie bars.
  - Tie bars should not be used to pull joint together.
  - Tension adjusting nut 1/2 turn past snug.
- Install Drainage Fabric
- Backfill

**Figure 13.2**



Set the first section of the outlet end first.

**Figure 13.3**



**Figure 13.4**



Place joint sealant on the floor of the female end (in the middle) from top of haunch to top of haunch.

**Figure 13.5**



- The joint sealant should be placed in the middle of the joint, not on the back edge as shown in the photo or front edge.
- Dig a groove approximately 1" deep and 2" to 3" wide in front of the female joint for the entire width of the bed so bedding material does not push into the joint.
  - The above photo shows the cut out groove.
- Prior to setting each section use the screed to reshape the bed and remove the material from the groove.



**Figure 13.6**



- Use pulling bracket and come-along system to pull the joints together.

**Figure 13.7**



- A bulldozer may be used to push sections together, but it is not recommended, as the bulldozer will tear up the bedding.

**Figure 13.8**



- Check the joint gap. If the gap is larger than  $3/4"$ , pull the joint apart and check for obstructions and check flatness of bedding surface.
- This maximum gap does not apply to the center wall of double cell boxed.
- Install tie bars. Tie bars should not be used to pull joint together. Tension adjusting nut  $1/2$  turn past snug.
- Install Drainage Fabric.

**Figure 13.9**



**Figure 13.10**



- Backfill

**Figure 13.11**



- Refer to Materials Manual (M.S.T.R.) for testing requirements.
  - 4. subgrade construction (embankments)

**Figure 13.12**



The following photos show some miscellaneous construction items for precast concrete box culverts:

Cutoff wall installation

**Figure 13.13**



**Figure 13.14**



**Figure 13.15**



**Figure 13.16**



**Figure 13.17**



## ANSWERS TO MANUAL'S PROBLEMS

### Page 7-33

0.6 feet

### Page 7-36

- A. 12 inches
- B. 6 inches
- C. 36 inches

### Page 7-41

- A. 6 feet to 6'8"
- B. 6 feet
- C. 1 foot
- D. 6 feet

### Page 8-48

- A. 3
- B. 5
- C. 4
- D. 4
- E. 4

# Erosion Control





INTRODUCTION	2
Chapter 1	
SEEDBED PREPARATION	3
Chapter 2	
SEED CERTIFICATION	8
PERMANENT SEED	9
COVER CROP SEEDING	11
TESTING	12
MEASUREMENT AND PAYMENT	12
Chapter 3	
SEEDING OPERATIONS (SECTION 730)	14
PRESS DRILLS	14
CALIBRATION	17
SEEDING	20
NO TILL DRILLS	21
HYDROSEEDING	21
HAND SEEDING-	22
Chapter 4	
FERTILIZING AND MULCHING	23
FERTILIZER (SECTION 731)	23
APPLICATION	24
MEASUREMENT AND PAYMENT	25
MULCHING (SECTION 732)	26
GRASS HAY AND STRAW MULCH	27
PUNCHING MULCH-	29
FIBER MULCH	31
APPLICATION	32
BONDED FIBER MATRIX	33
MEASUREMENT AND PAYMENT	34
GRASS HAY OR STRAW MULCH	34
FIBER MULCH	35
Chapter 5	
EROSION CONTROL TREATMENT AND LOCATION	37
CHANNEL PREPARATION	40
EROSION CONTROL BLANKET (SECTION 734) 41	
INSTALLATION	42
MEASUREMENT AND PAYMENT	45
SOD (SECTION 733)	46
SURFACE PREPARATION	47
INSTALLATION	48
MEASUREMENT AND PAYMENT	50
RIPRAP (SECTION 700)	52
INSTALLATION	53
MEASUREMENT AND PAYMENT	54
GABIONS (SECTION 1030)	55
FABRICATION	55
INSTALLATION	56
MEASUREMENT AND PAYMENT	59

SILT FENCE (SECTION 734) - - - - -	59
INSTALLATION - - - - -	60
MEASUREMENT AND PAYMENT - - - - -	61
Chapter 6	
ANSWERS TO MANUAL'S PROBLEMS - - - - -	62
Chapter 7	
STANDARD PLATES - - - - -	63

## Introduction

---

Erosion Control and Roadside Development are essential elements in the construction of roads. Environmental regulations have placed increased emphasis on these phases of construction.

This manual addresses various items involved in roadside development and erosion control construction. It contains the requirements that must be satisfied and method that can be used to satisfactorily complete work. The material in this booklet should in no way be considered all inclusive. The requirements and methods for this type of construction differ from project to project. To be certain of what the Contractor is required to do, you must always make a thorough review of the Plan Notes. Special Provisions, Supplemental and Standard Specifications for each project assigned.

It's better to prevent the erosion control issue before and during construction than to have erosion problems after construction and have to plan corrective measures. Selected handouts are contained in a n envelope in the back of this manual. They are referenced in the manual text as Handout 1, Handout 2, etc.

NOTE: Throughout this manual, reference is made to provisions of the South Dakota Standard Specifications for Roads and Bridges Manual. For example, (730.2 D) refers the reader to Section 730.2 paragraph D., labeling in the specification book. The Department of Transportation is grateful for and wishes to recognize the efforts of its employees who have made significant contributions to the improvement of this training manual. Those employees include:

Jim Hyde, Pierre Area

Sharon Kayser, Road Design

Steve Ryan, Road Design

## SEEDBED PREPARATION

Placing the topsoil and finishing it according to the requirements of the plans (cross section and thickness) is a part of seedbed preparation. Generally the topsoil is placed and finished as a part of the earthwork operation; so in this booklet, you may assume the topsoil is already in place.

**Figure 1.1** Proper seedbed preparation, including installation of erosion control blanket.



The seedbed must be prepared before any seed can be planted the first time. It doesn't matter when the topsoil was placed. The purpose of working the seed bed prior to seeding is to loosen the soil and to reduce the existing weed growth. The soil must be loosened so the seed can be placed at the proper depth. The weeds should be destroyed to stop competition for moisture. However, it may not be possible to kill all the weeds without making several attempts. If this is the case, it is better to leave a few weeds than pulverize the soil.

To prepare the seedbed, the soil needs to be worked enough to provide a bed for the seed to take root in and yet be left with roughened surface. The rough surface is needed

to retard erosion until the new growth becomes established. In doing this, it is required that the seed bed be worked to a depth of approximately 3 inches. The only exceptions to this requirement are:

1. Areas where there isn't enough topsoil to get a 3 inch coverage. In these areas, it only needs to be worked to the depth of the topsoil. Working it deeper will pull undesirable subsoil into the topsoil. Mixing the two will cause a downgrading of the topsoil's ability to sustain plant growth.

**Figure 1.2** Seedbed too chunky



2. Areas that are so steep that it is impossible to put equipment on them. Normally, these steep slopes are hydroseeded, meaning the seed is mixed with water and sprayed onto the slope. If the area is to be **hydroseeded**, no working of the seedbed will be required. If it is to be hand seeded, it will have to be worked up by hand. If the soil is left too chunky, it will be next to impossible to plant the seed at the proper depth. Also the large air voids will cause the soil to dry, resulting in the new plants dying from a lack of moisture. The soil should be worked until there are no clods over 3 inches (730.3 E.1). When the soil is over pulverized the slightest wind or rain can erode it to the point where the seed is lost. Finely worked soil also tends to form a solid crust when drying out after a rain. In many cases, the new plants die because they can't get through this crust.

The Contractor has a choice of what equipment he uses to work the seedbed. He may use a tool carrier having rigid shanks fitted with sweeps or chisels, or he may use a heavy duty disk. Both have problems in heavy or packed soils.

**Figure 1.3** Standard Disk.

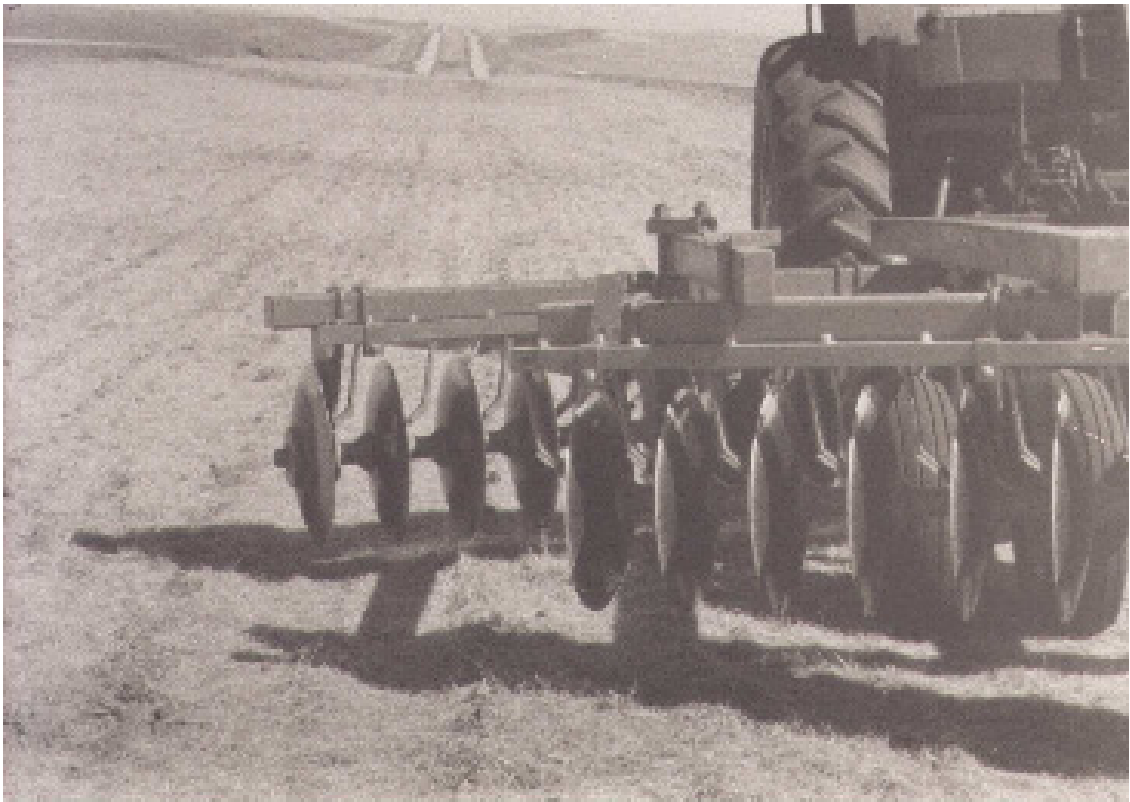

The tool carrier has a tendency to tear up large chunks that have to be broken later to get a satisfactory seedbed. When a disk is used in this soil, several passes are often needed to get the required depth. The proper depth should be obtained with as few passes as possible so the soil isn't over pulverized. If the soil is being over pulverized, they will have to put ballast on the disk or get a bigger, heavier disk. If this doesn't correct the problem they may have to use a tool carrier. In some cases use a tool carrier to first get the depth, and then a disk to break down the chunks.

Do all work needed to loosen the seedbed on the contour. Essentially, this is parallel with the roadway centerline. If work is done up and down the slope, runoff will follow the equipment furrows and start eroding the soil. By having to flow across furrows, the runoff is slowed, reducing erosion.

**Figure 1.4**

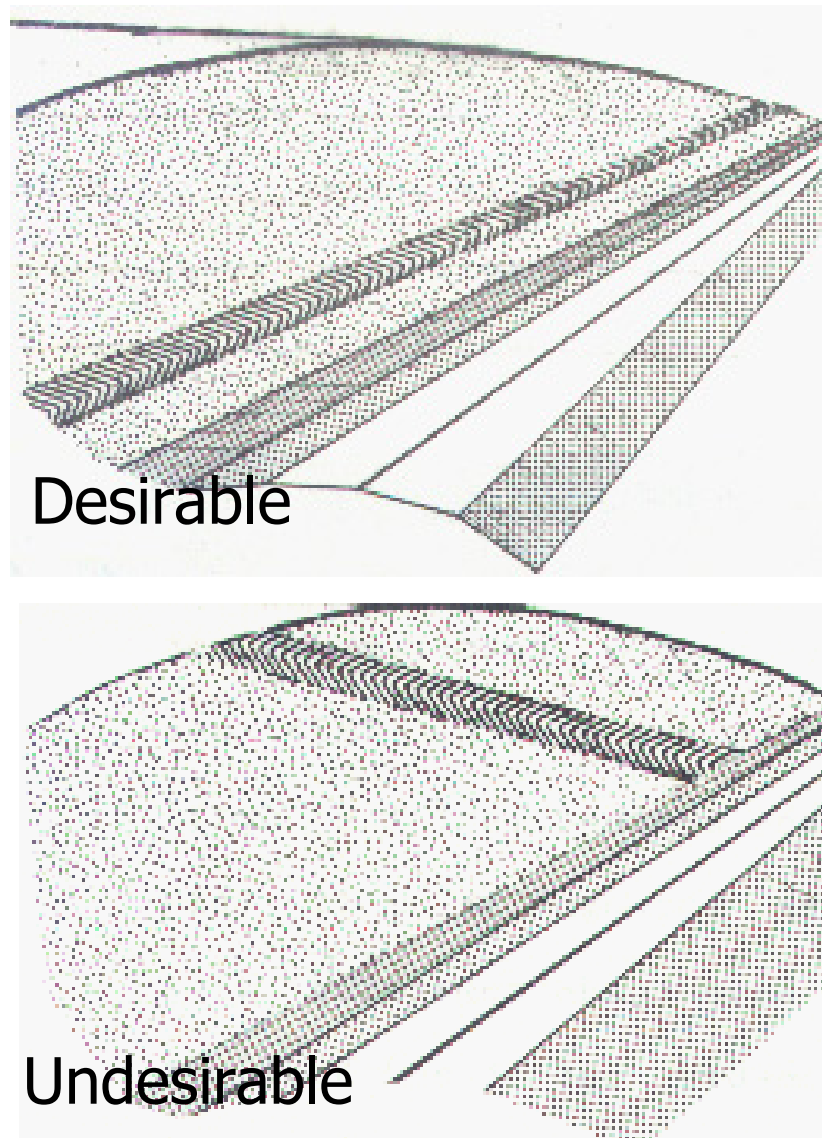

In some cases the inslopes or backslaps may be so steep or the soil so loose that side sliding or rutting occurs while trying to work on the contour. You may then allow work diagonally across the slope. This will give you the greatest erosion control because the runoff has to flow somewhat across the furrows. Some areas may have tall heavy growth that must be worked. We want a maximum amount of this growth left in the soil for its mulch and erosion control value. However, there are times when it hampers the drilling operation. And there are times when the growth is so heavy that even the disc is unable to operate properly.

When this occurs, you can require a rotary mower or some other method to be used to chop up the growth. This may still leave so much material on the seedbed that the drill or tillage equipment can't work through it. If this happens, then the Contractor will have to do something else to get rid of the growth...probably cut it and haul it away.

The seedbed does not have to be reworked when it is reseeded if the seed and fertilizer can be placed properly without it. Putting permanent seed back on an area where you didn't get a good catch of permanent grass from the first planting or in a cover crop area are both considered as reseeding. Cover crop areas will probably give you the most headaches, especially when the growth is heavy. If it causes a problem, the area must

be worked. The same procedures are to be followed except that the seedbed only needs to be worked to a depth of one to 1 1/2 inches.

Whenever possible reseed the areas without working up the existing growth. This growth is firmly rooted and is the best erosion protection you can get. Generally this growth consists of weeds and grain that will die once grass grows, and what isn't crowded out will be killed when Maintenance does weed spraying.

This reseeding can be done with a "no till drill" which allows you to drill seed directly into the existing growth without disturbing it. There are no limits on the speed equipment can travel when working the seedbed. The key is that the soil must be loosened to the proper depth. If you see the equipment bouncing, check the depth in a few places. They may need to slow down.

Occasionally you have a few areas where hand methods must be used to work the seedbed. The most common areas are on bridge berms, around box culverts, etc. There are no particular requirements on how this handwork is to be done or on what equipment to use. What the DOT wants is the crust to be broken and enough soil loosened to make a shallow bed for each seed. Generally hand rakes are used for this.

After the seedbed has been worked and prior to seeding, all rock that projects more than 3 inches above the surface and other rubbish must be collected (730.3 E.1). It must be removed so it won't hamper the normal operation of the drill or become a hazard for our maintenance mowers.



## SEED CERTIFICATION

The DOT does two types of seeding: permanent seeding and cover crop seeding. Permanent seeding is the planting of grass mixtures that are to become the permanent roadside growth. Cover crop seeding is the planting of a small grain to temporarily protect the slopes and ditches from erosion until permanent seeding is done.

Permanent seeding is generally all that is required on a packaged contract. It is felt construction activity will be done prior to seeding so nothing will tear up the new growth. Where the grading and surfacing are separate contracts, the grading contract usually calls for both permanent and cover crop seeding. Both are also used on those packaged contracts that are expected to take a long time to complete. The placement of the cover crop depends on the project location and on the preference of the Area Engineer. Some instances where cover crop may be used:

- 1** Sometimes the cover crop on a four lane divided highway is placed on the top 16 feet of the inslope, and the full width of the median; everything else gets permanent seed. The reason for using a cover crop in these areas is that the surfacing equipment will normally be on them, and it's less expensive to replace the cover crop than to replace permanent seed. Then, when all construction work is completed, the cover crop areas will be seeded with permanent seed.
- 2** Use cover crop on inslope, ditch bottom, and backslope on the grading project and on the surfacing project when permanent seed cannot be placed due to seasonal limitations.

The plans will contain notes specifying the seeding required and the location to be planted. The limits given are not absolute; they can be changed to meet conditions. If you find there are areas where the type of seeding should be changed, talk them over with the Area Engineer and Central Office staff and if he or she agrees, change it.

All of the seeds in any mixture must have been grown in South Dakota, North Dakota, Montana, Wyoming, Nebraska, Iowa, or Minnesota. In some instances, plans may allow a particular seed to come from some other state. All seeds of any species must be one of the varieties listed in the plans. The variety is important because these are generally proven to acclimate well to South Dakota's growing conditions (they are hardy).

Sometimes it is impossible for the Contractor to get seed that was grown in the allowed states. If this happens, he/she must get letters from three seed suppliers certifying that seed from these states are not available. At the same time, he should determine from which states he can get the seed. Once the Area Engineer has these letters, he must contact the Construction Program for a determination of an allowable substitute.

Before any seed can be planted, the Contractor must supply the Area Engineer with seed certificates and/or certified test reports (Handouts 1 & 2) for approval. Basically they both are the same, and the only differences is the title on the sheet. Regardless of which is supplied, it must contain the following information for each kind of seed:

- Name and address of supplier
- Lot number of each seed tested
- Date when each lot was tested
- Percent of germination
- Percent of dormant or hard seed
- Percent of purity
- Origin (where grown)

Be sure to read all the easement and borrow pit agreements for your project. Some will contain a statement that the landowner has been paid a lump sum to do his or her own seeding. Others may contain a specific seed mixture that is to be planted. As a general rule, easement agreements are set up to reseed in grassland areas and for no seeding in cultivated areas. If they don't say what is to be done, contact the Right-of-Way Office and find out what they want done.

# PERMANENT SEED

---

The plans will specify the seeds that make up the mixture to be planted. Some projects have more than one mixture, such as one for inside the right-of-way and one for temporary easements. The rate shown for each kind of seed is always given in pound of pure live seed (PLS) required per acre.

Pure Live Seed (PLS)

Intermediate Wheatgrass (Chief, Oahe, Slate).....	8 lbs. per acre
Western Wheatgrass (Rodan, Rosanna, Flintlock)..	4 lbs. per acre
Green Needlegrass (Lodorm).....	3 lbs. per acre
Alfalfa (Travois, Rambler, Teton)*.....	3 lbs. per acre
Total .....	18 lbs. per acre

\*One or any combination of these three. The Alfalfa shall be inoculated in accordance with Section 730.2 E of the Standard Specifications.

The reason the rate is specified in pure live seed is the DOT wants to make sure a certain amount of seed is planted that will grow. Bulk seed contains some foreign material (chaff, weed seed, etc.) and had some seed that won't germinate. By basing the rate on pure live seed, we are assured of getting the same amount of seed throughout the project that can be expected to grow. Each bag of seed must have a ticket on it listing the following:

- 1 Name and address of supplier
- 2 County and project number for which seed is to be used.
- 3 Suppliers lot number for each kind of seed in the mixture.
- 4 Origin (where grown) for each kind of seed.

- 5 Purity, germination, and other information required by South Dakota Seed Law, for each kind of seed.
- 6 Pounds of bulk seed of each kind of seed in the bag.
- 7 Total pounds of bulk seed mixture in the bag.
- 8 Pounds of pure live seed (PLS) of each kind of seed in each bag.
- 9 Total pounds of PLS mixture in each bag.
- 10 Dormant Seed and Hard Seed.

This is basically what order items would be written on a bag ticket. Some suppliers might place the information differently. You need to check the lot numbers, percent of germination, dormant seed, purity and origins shown on the bag ticket to see that they are the same ones shown on the certificates. If they don't agree, the Contractor must present the correct certificates for the seed before it can be planted. If the seed is of an origin other than what is allowed, it will have to be rejected or arrangements made for its acceptance. Using the bag tag just shown and the seed certificates (Handouts 1 & 2); can the seed be used? \_\_\_\_\_(A)

The pounds of pure live seed, of each seed, as shown on the bag ticket should be checked to make sure it is correct. Use the following formula to do this:

$$\% \text{ PLS} = \frac{(\% \text{ Germination} + \% \text{ Dormant or Hard Seed}) (\% \text{ Purity})}{100}$$

$$\text{PLS Weight} = \frac{\% \text{ PLS}}{100} \times \text{Bulk Weight}$$

(Your answer should check with the PLS weight on the bag ticket)

NOTE: Dormant or hard seed is seed that didn't germinate during the test period but will with a little more time.

EXAMPLE: Information obtained from a bag tag:

$$\begin{aligned} \text{Bulk Weight} &= 8.26 \text{ pounds} & \text{PLS Weight} &= 4.12 \text{ pounds} \\ \% \text{ Germination} &= 75\% & \% \text{ Dormant Seed} &= 7\% & \% \text{ Purity} &= 60.83\% \\ \% \text{ PLS} &= \frac{(75\% + 7\%)(60.83\%)}{100} = 49.88\% \\ \text{PLS Weight} &= \frac{49.88\% \times 8.26 \text{ pounds}}{100} = 4.12 \text{ pounds} \end{aligned}$$

Using the Intermediate Wheatgrass given on Handout 1, does the amount of PLS check out? \_\_\_\_\_(B)

You should check the pound of pure live seed of each type of seed to be sure that they are mixed according to the plan percentage. This can be done by:

1. Finding the percentage that each seed is of the plan rate.  

$$\% = \text{Plan Rate of each seed} / \text{Total Plan Rate}$$

2. Finding the percentage that each seed PLS weight is of the total PLS Weight in the bag.

Weight in the bag.

$$\% = \text{PLS Weight of each seed} / \text{Total PLS Weight}$$

3. Then comparing the two percentages. They should be within a few tenths percent of each other.

Use Handout 2 and plans requirement on page 1-8. Does this mixture meet requirements?

\_\_\_\_\_ (C)

Most Contractors will buy seed already mixed in the required proportions. Occasionally they will buy seed separately and mix it on the job site. When this happens, they will have to supply a scale to weigh each kind of seed so it can be mixed properly. The Contractor shall calculate the required proportions and the DOT shall verify. Make sure the seed is thoroughly mixed without harming the seed before it is used.

When legumes (alfalfa, clover, etc.) are included in the seed mixture, they must be inoculated with a nitrogen fixing bacteria before being planted. The purpose is to give the new plant the nitrogen it needs to grow until it can start producing its own. If the seed is not inoculated, there is a good chance that it will germinate but not continued to grow. The Contractor must supply a certificate stating that the inoculation was accomplished. Generally this inoculation is done when the seed is sold, so it will also show up on the bag ticket.

## **COVER CROP SEEDING**

---

The mixture used for cover crop seed contains small grains (winter wheat or oats). Each bag of cover crop seed must have a bag ticket on it. This ticket must contain the same information as required for permanent seed except that pure live seed weights are not needed.

Pure live seed weights aren't required because cover crop seed rates are based on bulk weights. But, to assure good seed, all cover crop seed must have a minimum of 75% pure live seed. If it doesn't meet the minimum, it must be rejected. The percent pure live seed is calculated the same as for the permanent seed.

The Engineer may order cover crop seeding if he determines such seeding is necessary to provide interim erosion control measures. Cover crop seeding can be used to control erosion during June and July when permanent seeding is not allowed by the seasonal limitation specification.

Seeding rate for cover crop should be one bushel (56 lbs./ acre).

Cover Crop seeding may be done at any time when soil and weather conditions are suitable, as determined by the Engineer. Use oats, April through July; Winter Wheat, August through November.

Cover Crop Seeding is to be measured and paid for at the Contract Unit Price Bid per Bushel. For purposes of Measurement and payment on all projects, one bushel of Cover Crop shall be considered to be 56 lbs, no matter if it is oats or winter wheat used. (Section 730.4)

## TESTING

---

The DOT requires seed mixtures to be planted within 9 months of the date it was tested or else it must be re-tested. All seed certificates (Handouts 1 & 2) and/or test reports must show the date that each seed was tested. By checking these dates, you can easily determine when the 9-month period ends. If a seed was tested on November 6, 1998, the time period would be up Aug. 6, 1999. It could not be used on Aug. 7, 1999, unless it was re-tested. Be sure to use the test dates from the certificates and/or test reports and not those shown on the bag tag. Generally they will be the same, but there are times when they differ.

It is your responsibility to see that the 9 months is not exceeded. It is the Contractor's responsibility to supply you with new certifications or test reports. Occasionally you will find that the Contractor has seed that he wants to use, but it is more than 9 months since it was tested. Have him or her contact the supplier to see if that particular lot of seed has been retested. If it has, have him or her get a certificate or test report showing the retest. If the supplier has not re-tested the lot and no longer has seed that can be retested, the Contractor must make arrangements to have a sample of the mixture retested for germination and dormant or hard seed. Purity is not retested but is considered to have remained the same. It takes about 30 days to run these tests. If it looks like the time limit might be exceeded, let the Contractor know far enough ahead of time so you can get the results when they are needed.

The retest results could show the percentages of germination and dormant or hard seed to be less or more than what it was originally. When cover crop seed is retested, just check to see if it still meets the minimum of 75% PLS. If it does, keep using it; but if it doesn't, the seed will have to be rejected. Regardless of what the retest results are for permanent seed, the rate of application will not be changed. We allow this because it would be too difficult to put in or take out some seed to maintain the mixture. When the results give a% PLS that is lower than before, it will be used to recompute the amount of seed the Contractor gets paid for. How this is done will be covered under Measurement and Payment. If the results show a higher PLS, nothing happens. The original PLS weights will be used for pay purposes.

## MEASUREMENT AND PAYMENT

---

Cover crop seed is measured and paid for in bushels of bulk seed to the nearest whole bushel. Generally the cover crop seed will be delivered in sacks containing one bushel, so just count the sacks to get the quantity used. Should it be delivered in bulk quantities, you will have to determine the bushels by dividing the total weight used by 56 pounds.

Permanent seed is measured and paid for in pounds of pure live seed to the nearest whole pound. This is the weight shown on the bag ticket unless a retest shows a lower percent of PLS. If the percent of PLS of any re-tested seed is lower than it was originally, you will have to refigure the pounds of pure live seed per bag. After you find the new PLS weight for the re-tested seed, you can find the new bulk weight of each bag by adding the PLS weights for each type of seed not tested plus the re-test seed PLS. This now becomes the new weight per bag that you use on your daily tally sheet or weight ticket. Be sure to put this information in your diary.

NOTE: Don't use the changed bag weight until after the 9 month period.

Handout # 2 is a bag ticket for some seed you are using. The Western Wheatgrass and Teton Alfalfa had to be re-tested. The Western Wheatgrass retest shows a germination of 80% and dormant seed of 0%. The Teton Alfalfa retest shows a germination of 61% and hard seed of 23%. What is the new total PLS weight for this bag? \_\_\_\_\_

Figure 2.1 Materials and Weight Ticket

SOUTH DAKOTA		DOT-75 (1984)
MATERIALS AND WEIGHT TICKETS		
PROJECT	I 90-5(41)247	
MATERIAL	Perm. Seed	
DATE	July 22, 1999	SAMPLE NO.
TANK OR CAR NO.		M. GALS.
TRUCK NO.		LANE
GROSS WT		SECTION
TARE WT		STATION
NET WT	343#	SPREAD
TONS		END STA
WEIGHER		CHECKER CC
CONCRETE MIX (TREATED MAT'LS)	WATER: MAX	ACTUAL
TIME START MIX	BATCH SIZE	
DISCHARGED		
REVOLUTIONS: RATE		INSPECTORS
FINAL		PLANT
INITIAL		PLACING
NET		
REMARKS:	130# sec 3 - 213# sec 4 42.89# each	
No. D 617601	BOOK QUANTITY	
	PREV. TICKET	
	THIS TICKET	
	TOTAL	

The quantity of seed to be paid for should be documented daily on the Construction Measurement and Payment System. Normally the seed will be furnished in bags and several bags of seed will be used each day. At the end of the day's work, there might be some seed remaining in the drill. Don't get overly concerned with what day this seed quantity is documented on. Its better to keep close tabs on the actual seed, fertilizer and mulch rates. However if you chose to document this remaining seed in the drill at the end of the day, keep it consistent throughout the project. Bag tags, commercial weigh tickets, or DOT-75 tickets shall be retained as source documentation.

Remember: Permanent seed is paid for in pounds of pure live seed. Cover crop seed is paid for in bushels of bulk seed.

## SEEDING OPERATIONS (SECTION 730)

After the seed certificates and/or test reports have been approved and the bag tags checked, the seed can be planted. There are basically three methods of planting seed that can be used:

- Press Drills
- Hydroseeding
- Hand seeding
- No Till Drill

In general, all permanent and cover crop seeding must be done with a press drill. Small areas and hard to get to places can be seeded by using a hydroseeder or hand methods.

Permanent seeding is not allowed from June 1 through August 1. Even though there is moisture and the weather is cool in June and maybe into July, there will be plenty of hot weather in July and August. This means the new seedlings will just get started and then be killed by the hot weather. This has happened on many projects resulting in poor stands of grass. The Region Engineer can waive this requirement if he or she feels it is beneficial to the project. Generally this will be the case if seeding a few days into June can complete the project. There may be other conditions that also qualify. If there is to be seeding between June 1 and August 1, the Region Engineer must approve the waiver.

There are no seasonal limitations on cover crop seeding. It is to be done as quickly as possible once the grading starts. The Area Engineer is to decide if the weather and soil conditions are suitable before this seeding is started. Neither permanent nor cover crop seeding is allowed when the ground is frozen. Also, no seed shall be sown on standing water.

### PRESS DRILLS

---

The Standard Specifications call for a press drill for seeding. The following plan note is used to allow some flexibility and still get the needed seed row compaction.

**Figure 3.1** Typical Press Drill



#### Drills for Permanent Seeding

Seeding may be done with drills other than press drills, providing they are equipped with packer wheels that follow directly behind double disk furrow openers and provide the same compaction obtained by a press drill. All other requirements as specified under Section 730.3E.3 shall apply.

When two drills are flexibly connected side by side, the maximum width is increased to 16 feet.

The drill must be equipped with individually mounted furrow openers of the double disk type. The maximum spacing between furrow openers cannot exceed 8 inches. Each furrow opener must be spring loaded and fitted with a depth band. There also must be a flexible hose connecting the seed box and the furrow opener. A hose connection can be between the fertilizer box and the furrow opener, but it is not required.

A depth band is a metal ring or drum about 1 inch wide that is attached by bolting it to or inserting it in slots on one disk of each furrow opener. The bands should be of a diameter that will leave 1 to 1 1/2 inches between it and the outside edge of the disk. The purpose of the depth band is to keep the furrow opener from going too far into the soil and the seed being planted too deep. You'll have to keep a constant check on the depth bands. The way they are attached is generally not too secure, and they tend to jiggle loose and fall off. If this becomes a problem, have the Contractor spot weld them to the disks.



**Figure 3.2** Drill for Permanent Seeding

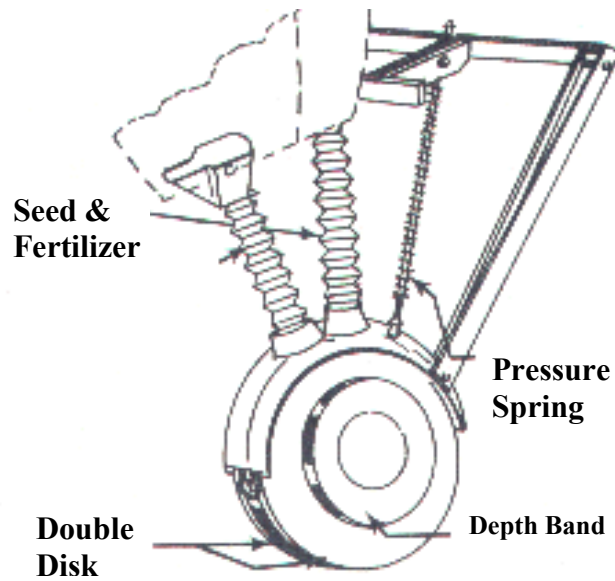

The pressure spring is what pushes the furrow opener into the soil and holds it there. You need to check to see that the springs are not broken and are set to give equal pressure to each furrow opener. If they are broken or don't exert enough pressure, the seed may not get planted deep enough. If they are set for too much pressure, the depth band may not be able to hold the furrow opener from being pushed in too deep, especially in loose soils.

The seed box of the drill must be equipped with a positive method of feed that can be set to accurately meter out the seed at a required rate. On most drills this is a vane feed that is driven by gears or chains locked to the forward speed of the drill. The seed rate is increased or decreased by moving more or less of the van feeder under the feed opening of the seed box or by adjusting a sliding gate in the feed opening. The adjustments for each opening must be linked so they can be set accurately. The lever used to set the rate must be able to be locked or held so it will not slip to another setting. There also must be an agitator over each feed opening. These prevent light seed from bridging over the feed opening and helped keep the seed thoroughly mixed.

The seed box must contain dividers spaced not more than 2 feet apart. They are to be flush with the top of the seed box and extend to within four inches of the bottom. These dividers can be homemade if they aren't already part of the box, and they will keep the seed from sliding around. Without them, the seed will slide to the lower end, when seeding on a slope, resulting in no seed being planted by part of the drill.

**Figure 3.3 Seed Box**

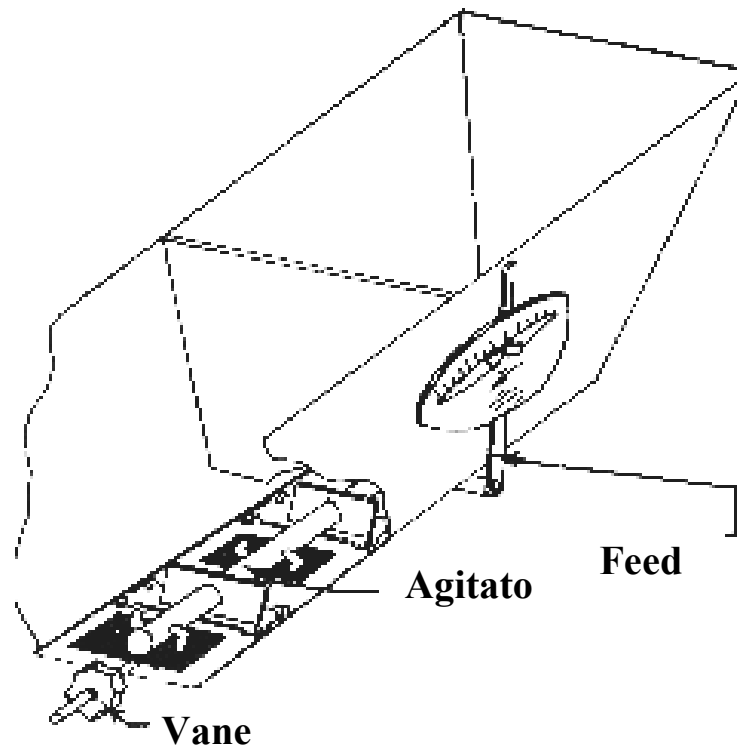

The drill is to have press wheels that follow directly behind each furrow opener. They must carry the major portion of the drill's weight and be mounted independently of the furrow openers. The press wheels are used to compact the soil over the seed, helping moisture retain around the seeds. The seed is to be between 3/4 and 1 inch below the surface after the press wheels have passed over it. Check this occasionally by digging down to the seed and measuring the depth. If the seed isn't planted deep enough, it won't get enough moisture to germinate and sustain growth. If it is planted too deep the seedling will die before reaching the surface and sunlight.

The drill shall be equipped with a metering device which will measure the area covered by the drill (usually an acre). In most cases, these meters read to the nearest 1/10 acre which is close enough. Using the meter eliminates the need to measure the area seeded which simplifies your documentation, but it is necessary to make sure that acreage meter is properly calibrated.

## **Calibration**

---

The drill must be calibrated to arrive at the setting needed to apply the seed at the plan designated rate. Different seed mixtures generally need different settings. About the only way to find the correct setting is to place seed in the drill and see how far it goes. If the Contractor remembers the setting he used before with similar seed, start with that setting. Also, most drills have a table in the seed box that gives settings to use for various types of seed. These can be used as a starting point. Here's how to calibrate the drill.

- 1 Set the feeder at a likely opening.
- 2 Put a bag of seed in each drill box.
- 3 Do the calibration over a fairly uniform area, such as a ditch or a fairly flat slope.
- 4 Start the seeding from some known station.

- 5 Watch the seed in the drill box and stop when it is all gone.
- 6 Determine the distance traveled.
- 7 Take the distance traveled times the drill width and divide by 43,560 square feet to get the number of acres seeded.
- 8 Divide the pounds of pure live seed used by the actual acres seeded, this will give the amount of PLS that was used in one acre.

EXAMPLE:

Plan rate = 18 lbs. per acre

PLS per bag = 40.17 lbs.

Drill width = 10 feet

Drill setting = 26

Distance Traveled = 8420 feet

Calibration Run # 1

Actual acres seeded =  $\frac{8420\text{ft} \times 10\text{ft}}{43560 \text{ sq ft/acre}}$  = 1.93 acres

Actual seed rate =  $\frac{40.17 \text{ lbs.}}{1.93 \text{ acres}}$  = 20.81 lbs./acre

The rate is higher than the plans rate thus the feeder setting must be decreased and another calibration run made.

Calibration Run # 2

PLS per bag = 40.17 lbs.

Drill Setting = 22

Distance Traveled = 9650 ft.

Actual Acres Seeded =  $\frac{9650 \text{ ft} \times 10 \text{ ft}}{43560 \text{ sq. ft}}$  = 2.22 sq. ft/ acre

Actual Seed Rate =  $\frac{40.17 \text{ lbs.}}{2.22 \text{ acres}}$  = 18.10 lbs./acre

**Figure 3.4 Seeding Drill**



If the rate is still off after the second try, a graph can be drawn by plotting settings against acres seeded. From the graph you can pick a setting that should be very close to giving the required rate. We realize that it is almost impossible to get the exact rate, but you should always try to get as close as you can.

Rule of Thumb: the calibration will be considered satisfactory when the actual acres seeded falls within +5% of the required acres.

A new graph is needed for each seed mixture. A new graph is also needed when there is a change in the pounds of pure live seed per bag. This is because the drill meters out bulk seed, if the bulk seed changes, the metered out amount must also change. Some seed mixtures use light fluffy seed. These seeds are rough to get through some drills at the specified seed rates. Some times the Contractor will have to make two passes to apply the correct rates.

The acreage meter should be checked for accuracy when the seed calibration is being done. It is always best to start with the reading on the meter rather than to turn it to set at zero. This means that an area could be covered before the meter locks up and starts to record the acreage. If the meter is not accurate, you will have to make use of a meter factor. The meter factor is found like this:

$$\text{Meter Factor} = \frac{\text{Actual acres (Use to the nearest 0.01)}}{\text{Metered acres}}$$

If you have to use a meter factor, the actual acres seeded are found by multiplying the meter factor times the metered acres.

NOTE: Put all calibration figures in the diary.

## PROBLEM:

Two identical eight foot drills are to be calibrated to seed the median. One bag of seed is put in each drill and the drill setting is set at 19. The PLS weight is 43.17 lbs. per bag and the required seed rate is 18 lbs. per acre. The seeding starts at Sta. 0+00, and finally goes to station 36+00, turns around and goes back to Sta. 0+00, turns around again and finally runs out of seed at Sta. 54+20. One acreage meter read 29.3 when starting, and it read 31.6 when it stopped. Can this drill setting be used?

\_\_\_\_\_ Is a meter factor needed? \_\_\_\_\_

The seed bed surface condition has an affect on the feed settings. When the ground is rough, you usually will need a lower setting because the seed feeds faster. On smooth ground the seed generally feeds slower so a larger setting is needed. The spread in settings for these conditions is around 4 points. This will vary between drills and for different conditions so check your rates and make the necessary changes.

## Seeding

---

All disturbed areas within the right-of-way are to be seeded except for the tops of roadways, other paved areas, and easements under cultivation. This includes equipment trails or any area where growth was removed or is lacking. Seeding outside the right-of-way is to be done only on the easement and borrow areas as called for by the plan notes or other agreements. If the Contractor stockpiles topsoil outside the right-of-way or easement boundaries or otherwise destroys the growth, it is his or her responsibility to reseed and the DOT does not pay for it.

Seeding on slopes is to be done in the same way as required for working the seedbed; on the contour where possible and adverse to the gradeline on steep slopes. Most seeding is done by turning around and coming right back beside the previous pass. These passes should not overlap. If you overlap, you will be planting more seed than needed.

There is no requirement on how fast the drill may travel. Five miles per hour seems to be about the top speed. Anything faster often causes the furrow openers to bounce, resulting in the seed not being placed at the proper depth. This bouncing also causes the feed hoses to come out of the furrow openers. You can have them slow down if speed is a problem.

The hoses leading from the seed box to the furrow openers should be checked several times each day to see that they are in place, not kinked and not plugged. Grass seed is pretty fluffy and quite often will catch and plug up the hoses. This can foul up your rate and leave you with unseeded areas.

You need to keep a constant check on the seeding rate. Field conditions make it difficult to hold the exact plan rate but you should always be striving for it. Occasionally something will happen and an area is either overseeded or underseeded. If it is underseeded by less than 4 pounds per acre, make the adjustments to get the correct rate and keep going. If it is underseeded by more than 4 pounds per acre, get the drill set for the plan rate and reseed it.

Quite often a fence line crosses a slope that is to be seeded. When it does, get as close to both sides of it as you can with the drill. We don't expect the Contractor to hand seed this small strip. As soon as the grass starts growing, it will spread in the area.

It is not necessary to keep source documentation on the acres seeded. But it is good to keep this information in your diary. Along with the number of acres seeded, it is also good to keep track of where the seeding was done (backslope, easement, borrow area, etc.) This information will be of value to you when figuring mulching rates.

## **No Till Drills**

---

No till drills are specifically designed to plant seeds directly through the existing vegetation. Most of the time No Till Drills are used to plant permanent seed directly into the existing cover crop planted earlier. This may include some weedy areas. The permanent seed will grow and take over the weeds. By seeding directly through the existing vegetation the soil and existing roots are disturbed less and will not erode as much compared to soil that was tilled. When No Till methods are used mulching is not necessary. No till drills shall not be used on areas that have been disked the seed would be planted too deep and not germinate.

There will be times when the existing growth is not sufficient to use No Till methods. In these cases, the Contractor will have to disk and seed with normal methods. A bid item for "tillage" is provided for those areas requiring cultivation prior to seeding. Tillage acres will have to be documented by field measurements.

## **HYDROSEEDING**

---

Hydroseeding is the process of mixing the seed with water and spraying it over the seedbed. The fertilizer is usually mixed in and applied at the same time. The Contractor is allowed to use this method of seeding when the slopes are so steep that a drill can't be used.

A hydroseeder is basically a huge tank with a pressure pump and a spray nozzle. Inside the tank there are agitators for keeping the seed mixed with the water. The agitator must be used at all times because without them, most of the seed would be floating on the water. This would make it impossible to apply the seed uniformly.

NOTE: When using a hydroseeder the seed and fertilizer are to be applied in one operation. Hydromulching must be done in a separate operation.

The amount of seed to mix with the water will vary and depends largely on the equipment being used. About the only way to determine if you have the right mixture is by trial and error. Probably the way to start is to ask the Contractor what he used in the past and start with that mixture. Adjustments can then be made based on the results you get.

There should be enough water in the mix so the ground will show a dampness when applied. This will help both you and the operator to see that the area is covered. It also will show you how uniformly the area was covered. Care should be taken not to have too much water in the mix. If there is, it will run off the slopes and it will carry the seed with it.

Like with the drill, you also need to calibrate the hydro-seeder. The best way to do this is by:

- 1 Getting the pounds of PLS added to the water.
- 2 Determining the area this seed should cover when applied at the plan rate.

**3** Measuring out the area needed.

**4** Applying the mixture.

If the area can't be covered or it isn't done uniformly, less seed should be used per tank of water. If some of the mixture is left over or too much water is being applied, more seed should be added to the mix. After finding the proper mixture, you should be able to maintain the rate by watching how wet the ground gets. This should keep you close to the plan rate, but you should still spot check the rate every day or so to find out exactly what rate you are getting. When seeding a slope, apply more seed at the top than at the bottom. Because the seed is on top of the ground, wind and rain will move it downward. In the end, this will result in the slope being uniformly covered.

Wind is a big factor in this type of seeding. Don't allow them to seed if wind keeps them from applying the seed uniformly or where you want it placed. Also, don't spread any seed on standing water. Wait until the water is gone before seeding the area.

## **HAND SEEDING**

---

Hand seeding is allowed for small areas and places that can't be seeded by other means. If hand seeding is needed, it is best if some type of cyclone seeder is used. The seed is fed continuously to the spinner, resulting in a fairly uniform application. When the seed is broadcast by hand, you generally end up with a spotty application.

Regardless of which is used, you'll probably be getting the seed applied heavier than the plan rate. However, don't worry, you're only putting it on a small area so any overseeding will have little effect of the total seed quantity.

After the seed has been applied, it must be worked into the soil to get the required cover. Generally this means that hand raking is needed.

## FERTILIZING AND MULCHING

### FERTILIZER (SECTION 731)

---

Fertilizer is to be applied in areas designated in the plans and on all areas that are to be sodded. Fertilizing gives the new plant the food it needs to grow into a vigorous mature plant. Three numbers, such as 18-46-0 identify the grade of the fertilizer. These numbers stand for the minimum percentages of each plant nutrient that the fertilizer contains. The first number (18) is the percentage of nitrogen, the second (46) is the percentage of phosphoric acid, and the third (0) is the percentage of water soluble potash.

NOTE: only the dry type of fertilizer is allowed for use.

The Contractor must supply the Area Engineer a certificate for the fertilizer before any of it is used on the project. The certificate must contain a statement that the fertilizer is registered for sale in South Dakota, a statement that it complies with the South Dakota Fertilizer Law in all other respects, the Contractor's name, the project number and county, the net weight, the name and address of the manufacturer, the brand and grade (guaranteed analysis showing minimum percentage of nitrogen, phosphoric acid and water soluble potash available in that order).

Each bag or container of fertilizer used must show the following information:

- Net weight of contents
- Name and address of manufacturer
- Brand and grade of fertilizer
- Guaranteed analysis of contents showing min % of nitrogen, phosphoric acid and potash

Generally this information is on the bag or container, rather than on a separate tag. Be sure to check the information against the certificate. If they don't agree, the Contractor needs to get new certificates before the fertilizer can be used.

The plans will designate the various grades of fertilizers that can be used, along with the rate at which it is to be applied. A substitution will not be allowed unless it is impossible for the Contractor to obtain the grade designated. If this should happen, the Road Design Office must be contacted for a determination of what grade can be substituted and if a change in rate is needed.



There are several ways the fertilizer can be applied:

- 1 The preferred method is using a fertilizer attachment on the drill during Seeding. Here the fertilizer is fed by hoses to fall behind the furrow openers. Fertilizer should not drop between the disks of the furrow openers since fertilizer will then be in direct contact with seed in the furrow and result in burning seedlings as they germinate. If the Contractor's equipment is set up this way, it is better to pull the fertilizer drop tube out of the disks and let the fertilizer drop on the closed furrow behind the openings, so soil separates the fertilizer from the seed.
- 2 The fertilizer can be applied separately with a drill prior to seeding.
- 3 The fertilizer can be broadcast over the seedbed prior to seedbed preparation. This method will not be allowed where no seedbed preparation is required. This method is very difficult to verify the application rate, and there is a lot of waste that should be deducted.
- 4 When the seed is applied by hydraulic means, the fertilizer can be mixed with the seed and water.
- 5 On areas where fertilizer cannot be applied with mechanical means, it can be spread by hand or with broadcast seeders and then must be hand raked in to a depth of approximately one inch.

Equipment used to apply the fertilizer must have a positive method of setting and controlling the rate. Generally these will be similar to those used for applying seed.

The equipment used to apply fertilizer must be calibrated. This can be done in the same way that the seed equipment was calibrated, by making calibration runs to find the setting that gives the required rate. A graph can also be drawn if needed. Where it is being applied with an attachment on the drill or with a hydro-seeder, both the seed and fertilizer can be calibrated at the same time. We realize that it is almost impossible to get the exact rate, but you should try to get it as close as possible. Write the calibration figures in the diary.

Rule of thumb: the calibration will be considered satisfactory when the actual acres fertilized falls within +5% of the required acres.

## APPLICATION

---

In cases where fertilizer is applied separately, the seeding must be done within 48 hours unless otherwise approved by the Area Engineer. The reason for getting the seed on quickly after applying the fertilizer is that it begins to release nutrients upon contact with the soil that means the longer it lays the fewer nutrients will be available for use by the growing plant. In hot weather this release will take place faster than in cool weather. About the only time it is reasonable to extend the 48 hour period is if the Contractor wasn't able to cover an area with seed because of rain. If it is a soaking rain, the fertilizer will be carried into the soil with very little loss. If it is a heavy washing rain, there is a possibility that the area will need to be re-fertilized. If this is the case, the Engineer must determine if the area is to be re-fertilized at the Contractor's expense.

Humidity affects the rate at which the fertilizer will meter out. When the humidity is high, the fertilizer becomes sticky and doesn't flow as freely as when the humidity is low. Check the application rate under different conditions so you know what settings to use. All the fertilizer in the hopper should be used or cleaned out at the end of each day. If it isn't, it will take on moisture which generally causes the metering device to become plugged. Also, the fertilizer loses strength if left in the hopper very long.

You need to keep a constant check on the fertilizer rate. Here is how to spot check the rate:

- 1 Determine how many acres were fertilized. This is the ending minus the beginning meter readings. If a meter factor is being used, multiply it times the metered acres to get the actual acres.
- 2 Divide the actual acres into the pounds of fertilizer used, and you have the actual rate of application.

There may be times when the fertilizer gets applied at something other than the desired rate. If you have an area where too much fertilizer is applied, cut the rate back to what it should be and keep going. If the area is under-fertilized by less than 20% of the plan rate, correct the rate and keep going. If it is under-fertilized by greater than 20% of the plan rate, make the necessary corrections and re-fertilize the area.

The extra fertilizer, due to being over the plan rate or re-fertilizing, will be paid for unless it becomes a habit. If that happens, check with your supervisor for a decision.

The plan rate calls for the fertilizer to be applied at 100 pounds per acre. Six 50 pound bags of fertilizer were put in the drill. The acreage meter read 48.7 when they started and 52.3 when the fertilizer was used up. It has a meter factor of 1.14. What do you need to do? \_\_\_\_\_

## **MEASUREMENT AND PAYMENT**

---

Fertilizer shall be weighed to the nearest 0.01 ton and a weight ticket issued for each load. Bag tags, commercial weigh tickets, or DOT-75 Forms shall be retained as a source documentation. Quantities shall be entered in Construction Measurement and Payment System.



## **GRASS HAY AND STRAW MULCH**

---

Standard Specifications allow grass hay or straw to be used, at the same application rate.

There are no certificates or test required for grass hay or straw mulch, but as per Policy Number OC-2001-09, grass hay or mulch material shall be substantially free of noxious seeds. All much bales shall be inspected for possible noxious weed infestation. Area Office staff should contact the local County Weed Supervisor or if not available, the County Extension Educator or South Dakota Department of Agriculture if the inspector has questions regarding the identification of certain plants/seeds in the mulch. Any mulch containing noxious weeds/seeds that is designated for our projects will be subject to rejection.

The hay or straw must be in good condition, baled and relatively dry when used. Any mulch that is spoiled, rotten, or easily breaks into small pieces shall be rejected. If it ages, it tends to deteriorate, which means it will be hard to apply and will give less erosion protection than new mulch.

The Contractor may stockpile his mulch on the project. We are not overly concerned about the weight of this mulch when put into the stockpile. However, it is good to know the quantity of mulch stockpiled. Occasionally we are asked to provide the landowner with the amount of material that a Contractor has stockpiled for use on the project. When the mulch is being taken from the stockpile and used on the project is the time that it must be weighed for our documentation. On small quantities when there isn't a scale on the project you can weigh one load to determine an average weight per bale and use that weight to determine the quantity.

### **Application**

The plans contain a note where the mulch is to be placed and the rate to use. In general, these should be followed but they can be changed for special situations. If you have a soil that is light or sandy, you may need to increase the rate in order to have adequate protection after punching. There may also be times when mulch should be placed on a cover crop area to keep it from eroding. When these conditions exist, talk that situation over with the Area Engineer.

There are three types of mulch applicators:

- 1** Mulch blower - Utilizes the small square grass hay or straw bales.
- 2** A Tub Type Mulcher - Utilizes the large round grass hay or straw 1000 pound bales.
- 3** The Hydro "Spreader" - Mulcher - Utilizes a "Fiber- Papery" type material.

Mulch is applied to permanent seeding areas as per plan notes. In some rare cases, hay or straw mulch may be applied before seeding as a temporary erosion control measure.

### **Mulch Blower**

The mulch blower is designed to chop and blow hay or straw. There isn't much to check on the blower as long as it will maintain a constant air stream and blow out the mulch in a fairly uniform stream. Inside the machine there are beaters used to break up the bales. Generally this beater consists of several lengths of chain attached to a shaft that turns at a high rate of speed.

**Figure 4.2** Mulcher.



The length of these chains pretty much determines the length of the mulch. The DOT prefers that most of the mulch have a length of around eight inches. If the mulch is being chopped too fine, have the Contractor shorten the beater chains to eliminate the problem. In some cases, the mulch is so old and dry that nothing will keep it from being broken into small pieces. If that happens, reject that load of mulch.

### **Tub Type Mulcher**

Large round bales of hay or straw are used for the Tub-Type Mulcher. The bales can be up to 1,150 pounds. The bales are reduced to individual hay or straw pieces by the use of metal teeth which help “unwind” the bale. If the material is dry and in good condition, the machine can do one bale each in approximately 5 minutes.

Once the hay or straw is stripped from the bale, it can be thrown through the air up to 35 feet from the machine. The mulch must be applied to an area as uniformly as possible. Generally, the depth of the loose mulch should be somewhere between 1/2 and 1 inch and approximately 10% of the soil surface will show through the mulch blanket. We must avoid having the mulch placed in piles which smother and kill the new seedlings.

If the mulch is “bunched” there are several possible causes:

- 1** The mulch is too wet making it impossible for the machine to separate and spread uniformly. If this is the case, the mulch should be left to dry or be rejected.
- 2** The operator is not moving the blower back and forth enough to give an even coverage. If this is the case, the operator’s method should be corrected or the operator should be replaced.
- 3** The mulch is being blown against the wind. If this is the problem, the mulch should be blown with the wind or stopped until the wind is less.

Whenever the mulch is being placed too heavy or in bunches, you may direct the Contractor to “square-up” the area. Generally this means using hand forks to spread the mulch uniformly. If they apply the mulch too thin, have them go back over the area and add what is needed.

Mulching should not be done during excessively high winds. This becomes a judgement matter. As long as the mulch is applied uniformly and stays on the area until it can be punched into the seedbed, there is no need to be concerned about the wind. In fact, sometimes wind carries the mulch to areas that otherwise would be hard to get at.

Maintaining the correct application of the mulch is somewhat difficult. The Contractor should be able to apply the mulch within + 10% of the required rate. Your notes kept during the seeding should have the acreages for the various area on the project. With this acreage information, you can keep a fairly close check on the application rate by doing the following:

- 1 Determine the mulch needed to cover the area by taking the rate times the acreage.
- 2 Find the average weight per bale by dividing the load weight by the bales in the load. (small, square, or large round).
- 3 Find the bales needed to cover the area by dividing the weight needed for the area by the average weight per bale.

EXAMPLE: Small Square Bales

Application rate = 2 tons per acre

Area = 3.7 acres

Weight load= 17,280 lbs

Large round bales in load =18

Calculations:

Weight needed for area = 2 tons per acre x 3.7 acres 7.4 tons or 14,800 lbs.

Average Weight per bale = 17,280 lbs.

Large Round bales = 18 bales

= 960 lbs. per bale

Bales needed for area:

Large Round = 14,800 lbs. = 15.4 bales

960 lbs.

Generally, it is required that traffic and equipment be kept off the seeded area. Therefore, the mulcher should be operated from the roadway or the top of the backslope whenever possible. If mulch is applied when the highway is open to traffic, the equipment could become a traffic hazard. In this case, it is better to let them operate on the seeded area. There are also occasions when wide areas require that the mulcher be allowed to travel on the seeded area to properly apply the mulch. In all cases, the traffic on the seedbed should be held to a minimum.

## **Punching Mulch**

---

Immediately following the application of mulch, the mulch puncher is used to punch it into the soil. The disks of the puncher shall be flat dull disks approximately 20 inches in diameter and 1/4 inch thick and have notched or cut out edges. The disks are to be spaced approximately 8 inches and shall be fitted with scrapers. Each member of the

puncher shall not exceed 6 feet in length but may be operated in flexible gangs of three for a total width of 18 feet.

**Figure 4.3** Mulch Puncher.

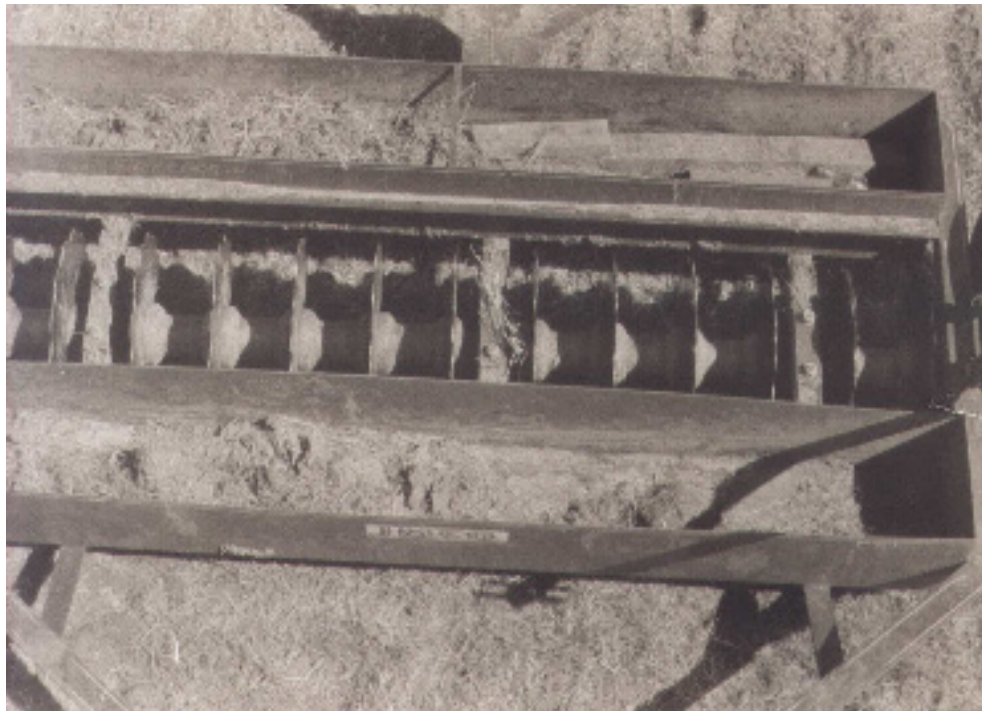

The puncher is to be operated on the contour in the same fashion as the disk and drill. In areas where the slopes are so steep that side sliding or rutting is caused, you may allow them to operate across the slope adverse to the grade line.

The mulch on areas being seeded for the first time is to be punched into the soil approximately 3 inches, with the ends exposed about the surface. An easy way of checking is to paint a few marks 3 inches in from the edge on some of the disks. Then you watch these marks to tell if the mulch is being punched to the right depth. Whenever mulch is placed on a reseeded area, it only needs to be punched in for a depth of 1 1/2 inches.

In heavy soils it may be necessary to place ballast on the puncher or to make several passes to get the proper depth. It is allowable to pull one puncher behind the other. The passes should be held to a minimum because of the possibility of breaking up too much of the mulch. Where the soil is light or sandy, something may need to be done to keep the puncher from going in too deep. Usually you can lower the puncher wheels to carry some of the machine's weight. In some cases, balloon tires may need to be used.

Often times the edges of the puncher disks will wear down to the point where they cut rather than punch the mulch into the soil. You can check this by pulling some mulch out of the soil. If you find more cut pieces than punched pieces, have the Contractor put new disks on the puncher.

After the punching has been completed, keep traffic and equipment to a minimum. Any ruts caused by the equipment or areas where the workers disturb the mulch could lead to an erosion problem. If the Contractor causes any damage, he/she must repair it at his/her expense.

## FIBER MULCH

---

Fiber mulch is a material that looks a lot like finely shredded paper that has been soaked in water and then left to dry. Before any of it can be used on the project, the Contractor must supply the Area Engineer with a certificate stating that the product they intend to use has been tested and meets the requirements of fiber mulch. No further testing is required.

The plans will contain a note stating where the mulch is to be applied and the rate to use. Here again, these can be adjusted to fit the conditions of your project.

Fiber mulch shall be applied in a separate operation following permanent seeding and fertilizing.

Rate of application shall be 2000 lbs. per acre unless otherwise directed by the Engineer. Excessive thickness of mulch that will smother grass seeding shall be avoided. Mulch shall be placed on a given area as soon as possible, or within forty-eight (48) hours after seeding, unless otherwise approved by the Engineer.

Material supplied for use in mulching shall contain no germination or growth inhibiting factor and shall have the property of becoming evenly dispersed and suspended when agitated in water. When sprayed uniformly on the surface of the soil, the fibers shall form a blotter-like ground cover that will readily absorb water and allow infiltration to the underlying soil without restricting emergence of seedlings. Weight specifications from suppliers, and for all applications, shall refer only to air dry weight of the fiber, considered to be 10 percent moisture.

The mulch material shall be supplied in packages marked by the manufacturer to show the air dry weight content. Suppliers shall certify that laboratory and field testing of their product has been accomplished, and that it meets all of the foregoing requirements.

Material for fiber mulching (measured by the ton, 2000 lbs., to the nearest one-tenth of a ton of satisfactory mulch and applied in accordance with the foregoing requirements) shall be paid for at the contract unit price per ton for fiber mulching.

Fiber mulch is generally supplied in large bales. Each bale must have a weight ticket on it, giving the air dry weight of the material with 10% moisture in it. At times, these tickets will show both the gross weight and the air dry weight. The only weight you need is the air dry weight.



**Figure 4.4** Weight Ticket.

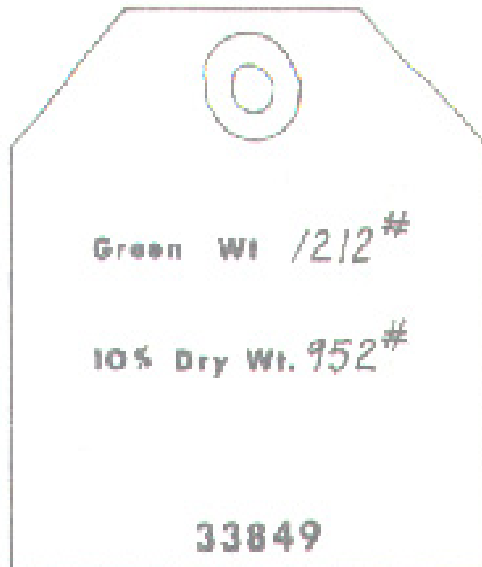

## **APPLICATION**

---

The fiber mulch is to be applied as a water slurry, using hydraulic equipment. The amount of water used will be dependent upon the equipment being used and the uniformity of the application. The Contractor may have some idea of the amount of water necessary but it will probably be a trial and error affair. The holding tank of the hydraulic equipment must have a built in agitation system to thoroughly mix and keep the fiber mulch suspended in the water until the slurry is sprayed on the soil. The discharge spray must be equipped with an adjustment or spray nozzle, which provide a choice of spray patterns for an even distribution of the slurry.

**Figure 4.5** Application of Fiber Mulch.

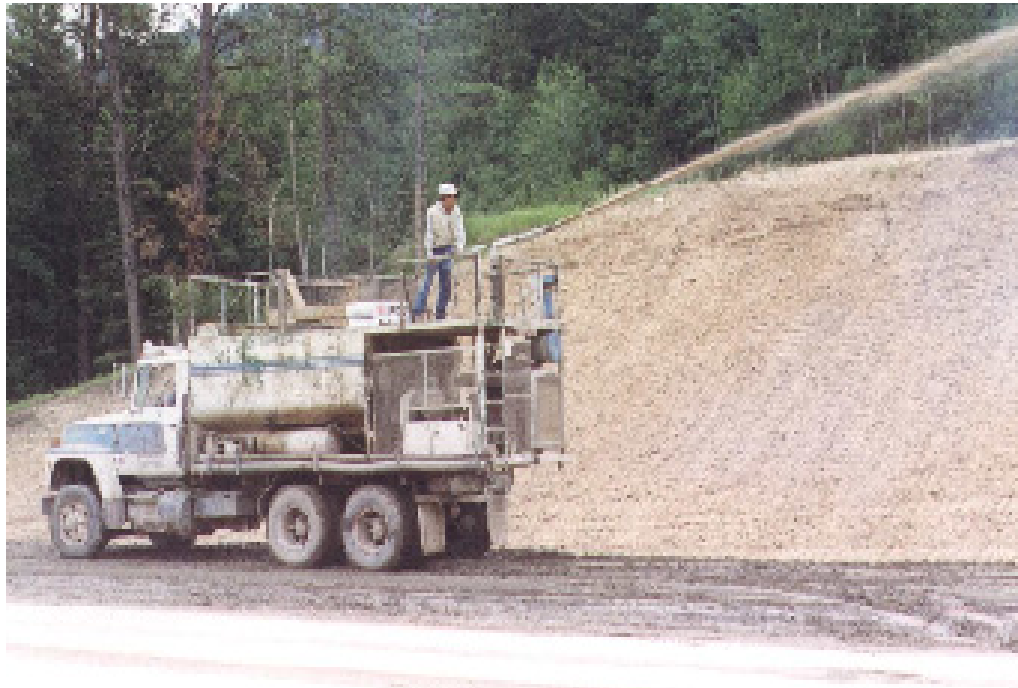

Fiber mulch is formed when the fibers are mixed with water. This forms a sticky substance that glues to the soil to help prevent erosion. As it dries, it forms a thin blotter like coverage that ties the area together. To get this condition, the slurry must be applied uniformly in a thin layer. You also have to watch that it isn't applied in globs, because the new seedlings then may be unable to punch through.

You also need to calibrate so you know when you are getting the desired rate. The calibration can be done as it was for hydroseeding.

- Find out how much fiber mulch was put into the slurry.
- Determine the area that should be covered with this mulch when applied at the plan rate.
- Measure the required area.
- Apply the slurry.

If it doesn't cover the area, they probably applied the slurry too heavy. If they had slurry left over, they weren't applying it heavy enough. In this case, they can go back over the area to compare the application. Once you get the right application, you should be able to check the rate just by looking. It is good to spot check the rate every day or so to assure the desired rate is being maintained.

After the mulch has been applied, take precautions to keep all traffic and equipment off the mulched area. Disturbing the mulch after it has been placed breaks its bond with the soil and the erosion protection is lost. If an area is disturbed, the Contractor must repair it at their expense. Using the rate from the previous note and the weight from the weight ticket, how long a stretch should you mark off if the slurry can be applied to an area 100 feet wide?

## **BONDED FIBER MATRIX**

---

Bonded fiber erosion control treatment shall consist of a continuous layer of elongated fiber strands held together by a water resistant bonding agent. The bonded fiber matrix

shall be uniformly applied and shall have no gaps between the product and the seeded soil. The product shall be 100% biodegradable and composed of 90% wood fiber, 9% natural binder and 1% organic and mineral activators (all by weight). The treatment shall be installed with hydraulic seeding equipment.

Rate of application shall be 3900 pounds per acre and the mix shall consist of 50 pounds bonded fiber matrix to 125 gallons water unless otherwise specified by the Engineer. Treatment shall be placed on a given area as soon as possible, or within 48 hours after seeding. Bonded fiber erosion control treatment will be paid for at the contract unit price per ton. Payment will be full compensation for furnishing, hauling, and placing and for materials, equipment, labor, tools, and incidentals necessary.

Bonded fiber erosion control treatment shall be measured to the nearest 0.1 ton of mulch applied. Remulching of areas damaged by means beyond the control of the Contractor will be measured and added to the original quantities used.

**Figure 4.6** Typical Application of Bonded Fiber Erosion Control Treatment.



## **MEASUREMENT AND PAYMENT**

---

All material used for mulch is measured and paid by the ton to the nearest 0.1 of a ton.

### **Grass Hay or Straw Mulch**

---

A weight ticket must be issued for each load of hay or straw used on the project. If the Contractor has a scale, you can use it to weigh the mulch. If they do not have a scale on the project, a commercial scale can be used. When a commercial scale is used, you must be present for the weighing, except when the man or woman doing the weighing is a bonded weigher. The gross and tare weight of each load of mulch is to be weighed to the closest weight that can be read on the scale. The net weight is converted to the nearest 0.10 ton and entered on the ticket. This becomes the pay quantity for that load.

These weight tickets become the source documentation for the payment of the mulch; so be sure they are dated and signed or initialed. Quantities shall be entered into the Construction Measurement & Payment System.

Figure 4.7 Weight Ticket

DOT 75  
(1-84)

# SOUTH DAKOTA

MATERIALS AND WEIGHT TICKETS							
PROJECT	<u>I 90-5(41)247</u>						
MATERIAL	<u>Hay Mulch</u>						
DATE	<u>July 22, 1999</u>						
TANK OR CAR NO.	SAMPLE NO. _____						
TRUCK NO.	M. GALS. _____						
GROSS WT.	LANE _____						
TARE WT.	SECTION <u>3</u>						
NET WT.	STATION _____						
TONS.	SPREAD _____						
WEIGHER	END STA _____						
CHECKER	CHECKER <u>CC</u>						
<table style="width: 100%; border-collapse: collapse;"> <tr> <td style="width: 50%; border-right: 1px solid black; padding: 5px;"> <b style="font-size: 1.2em; color: red;">No. D 617603</b> </td> <td style="padding: 5px;"> <table style="width: 100%; border-collapse: collapse;"> <tr> <td style="text-align: center; border-bottom: 1px solid black;">BOOK QUANTITY</td> </tr> <tr> <td>PREV. TICKET _____</td> </tr> <tr> <td>THIS TICKET _____</td> </tr> <tr> <td style="border-top: 1px solid black;">TOTAL _____</td> </tr> </table> </td> </tr> </table>		<b style="font-size: 1.2em; color: red;">No. D 617603</b>	<table style="width: 100%; border-collapse: collapse;"> <tr> <td style="text-align: center; border-bottom: 1px solid black;">BOOK QUANTITY</td> </tr> <tr> <td>PREV. TICKET _____</td> </tr> <tr> <td>THIS TICKET _____</td> </tr> <tr> <td style="border-top: 1px solid black;">TOTAL _____</td> </tr> </table>	BOOK QUANTITY	PREV. TICKET _____	THIS TICKET _____	TOTAL _____
<b style="font-size: 1.2em; color: red;">No. D 617603</b>	<table style="width: 100%; border-collapse: collapse;"> <tr> <td style="text-align: center; border-bottom: 1px solid black;">BOOK QUANTITY</td> </tr> <tr> <td>PREV. TICKET _____</td> </tr> <tr> <td>THIS TICKET _____</td> </tr> <tr> <td style="border-top: 1px solid black;">TOTAL _____</td> </tr> </table>	BOOK QUANTITY	PREV. TICKET _____	THIS TICKET _____	TOTAL _____		
BOOK QUANTITY							
PREV. TICKET _____							
THIS TICKET _____							
TOTAL _____							

## Fiber Mulch

The supplier must provide you with weights for materials as they are delivered (per bale, sack, truckload, etc.). Gather all total number of bales, sack or truckload and make out a weight ticket for the material used each day. Make sure to round the quantity to the nearest tenth of a ton. Quantities shall be entered into the Construction Measurement & Payment System.

All mulch material will suffer some loss during stockpiling and handling or waste. A deduction for this lost material will need to be made as you can only pay for what was actually placed on the project. The best way to handle the situation is to get with the Contractor and arrive at an agreement on the amount to be deducted. Then write out a weigh ticket for the amount. Also put a statement such as "Deduction Due to Waste" in the Remarks area of the ticket.

Figure 4.8 Weight Ticket.

DOT-75  
(1-84)

## SOUTH DAKOTA

**MATERIALS AND WEIGHT TICKETS**

PROJECT I 90 - 6(18) 15  
MATERIAL Fiber Mulch  
DATE July 22, 1999 SAMPLE NO. \_\_\_\_\_  
TANK OR CAR NO. \_\_\_\_\_ M. GALS. \_\_\_\_\_  
TRUCK NO. \_\_\_\_\_ LANE \_\_\_\_\_  
GROSS WT. \_\_\_\_\_ SECTION 6  
TARE WT. \_\_\_\_\_ STATION \_\_\_\_\_  
NET WT. 7918# SPREAD \_\_\_\_\_  
TONS 3.96 END STA. \_\_\_\_\_  
WEIGHER \_\_\_\_\_ CHECKER CC

---

CONCRETE MIX (TREATED MAT'LS) WATER: MAX. \_\_\_\_\_ ACTUAL \_\_\_\_\_  
TIME START MIX \_\_\_\_\_ BATCH DISCHARGED \_\_\_\_\_ SIZE \_\_\_\_\_  
REVOLUTIONS: RATE \_\_\_\_\_ INSPECTORS: \_\_\_\_\_  
FINAL \_\_\_\_\_ PLANT \_\_\_\_\_  
INITIAL \_\_\_\_\_ PLACING \_\_\_\_\_  
NET \_\_\_\_\_

REMARKS: Section 6 - 952# - 1017# - 986#  
963# - 1032# - 1008# - 973# - 987#

---

<b>No. D 617604</b>	BOOK QUANTITY
	PREV. TICKET _____
	THIS TICKET _____
TOTAL _____	

LEAVE THIS SLIP IN BOOK

## EROSION CONTROL TREATMENT AND LOCATION

The material the DOT presently uses to control ditch erosion resulting from water runoff ranges from erosion control blankets, erosion bales, wattles, rock check dams, rip rap, bank & channel protection baskets and downspouts. In general the erosion control blanket and erosion bales or wattles are used in locations where the runoff is small and water spouts are used where the quantity of runoff is large and water velocities are high.

The locations and quantities shown on the plans are approximate locations. The Engineer will have to make adjustments as needed to utilize the proper materials in the proper locations. The Erosion Control portions of the plans are very good guidelines. Don't install erosion control materials where they are not needed and if more erosion control is needed then have the Contractor install more. If for some reason the grading has changed (extra borrow, borrow eliminated, grade changes etc.) or if there is additional drainage to be handled, the Engineer will have to determine what the best method is to prevent erosion. The Engineer should consult the Road Design office and/ or the Hydraulics Office on major drainage projects. Additional drainage over the backslope or from outside the grading area can cause major erosion problems and the Engineer should look out for these areas and protect them.

This can be done by using the Ditch Velocity Graph. (Handouts 3 & 4)

Two basic pieces of information are needed to use the graph:

1. The size of the drainage area contributing to the point under consideration.
2. The slope of the ditch at the point under consideration.

The information needed to use the graph can be easily obtained. The size of the drainage area can be found by making use of the slope stake notes, by measuring with a tape or chain or in some cases the survey crew could measure the area. The slope of the ditch can be found by using a rod and level or a hand level and a tape or chain.

Once you have this information, the water velocity at any point along the ditch can be found by using the Ditch Velocity Graph. Here are the steps to follow:

1. Refer to the Ditch Velocity Graph (Handout 3). Locate the size of the drainage area on the left side. From that point go to the right on a straight line until you intersect the curved line that is labeled with the slope you have found on the ground. (If your slope is not one of the even percentages given on the graph, you will have to estimate where it is between the appropriate curves.) Then go down on a straight line from the point of intersection and read the water velocity in feet per second at the bottom of the graph.

2. Refer to the table titled "Permissible Water Velocities for Ditches without use of erosion control blanket etc., to be used with Ditch Velocity Graph" (Handout 4)/ This table is used with the graph to determine if the water velocity is great enough in the area to warrant some erosion protection. It lists the various soil materials along with the maximum water velocity each type can withstand before erosion protection is necessary. So you must determine the soil material you have at the location you are working. Then, by checking the velocity you found with the velocity graph against the allowable velocity given on the table, you can determine the needed ditch protection. In other words if the velocity determined on the graph is greater than the velocity allowed on the table, you need ditch protection.

**Figure 5.1**

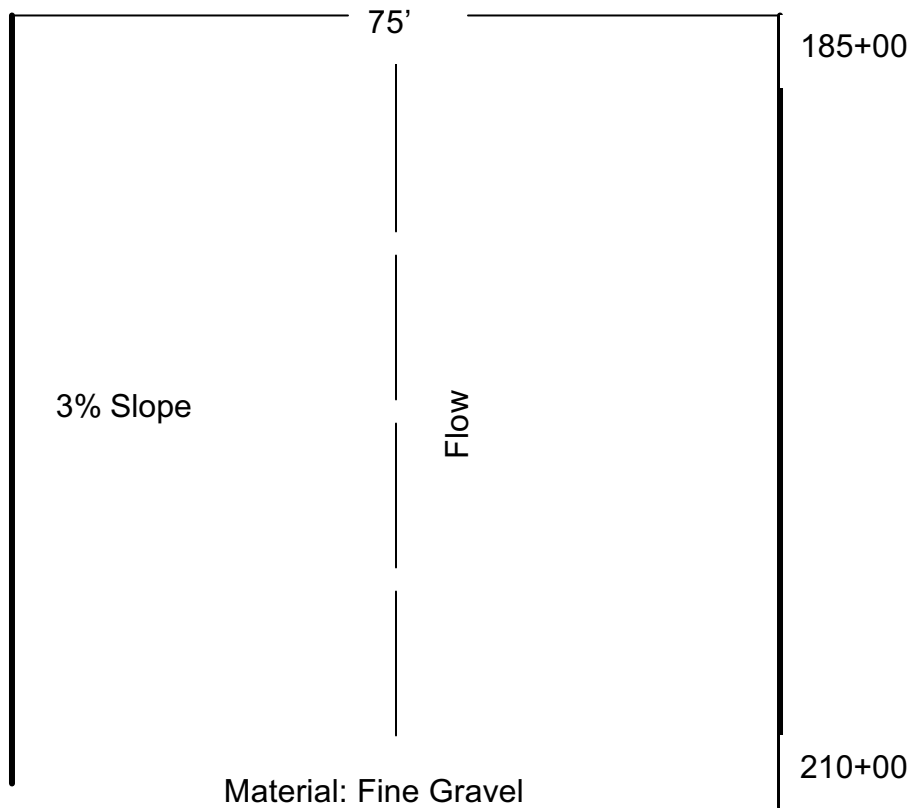

Problems:

1. What would be the water velocity of 90,000 sq. foot drainage area with a 3% slope? \_\_\_\_\_
2. A drainage area is 4000 ft. long and 75 ft. wide. The ditch slope is 1%. The soil in the ditch is a slit loam. What is the water velocity of the drainage area? \_\_\_\_\_  
Does it need erosion protection? \_\_\_\_\_
3. In the situation above, the ditch slope is 3% from station 185+00 to station 210+00 (2500 ft.). The drainage area is 75 feet wide. Will this ditch need erosion protection? \_\_\_\_\_

Figure 5.2

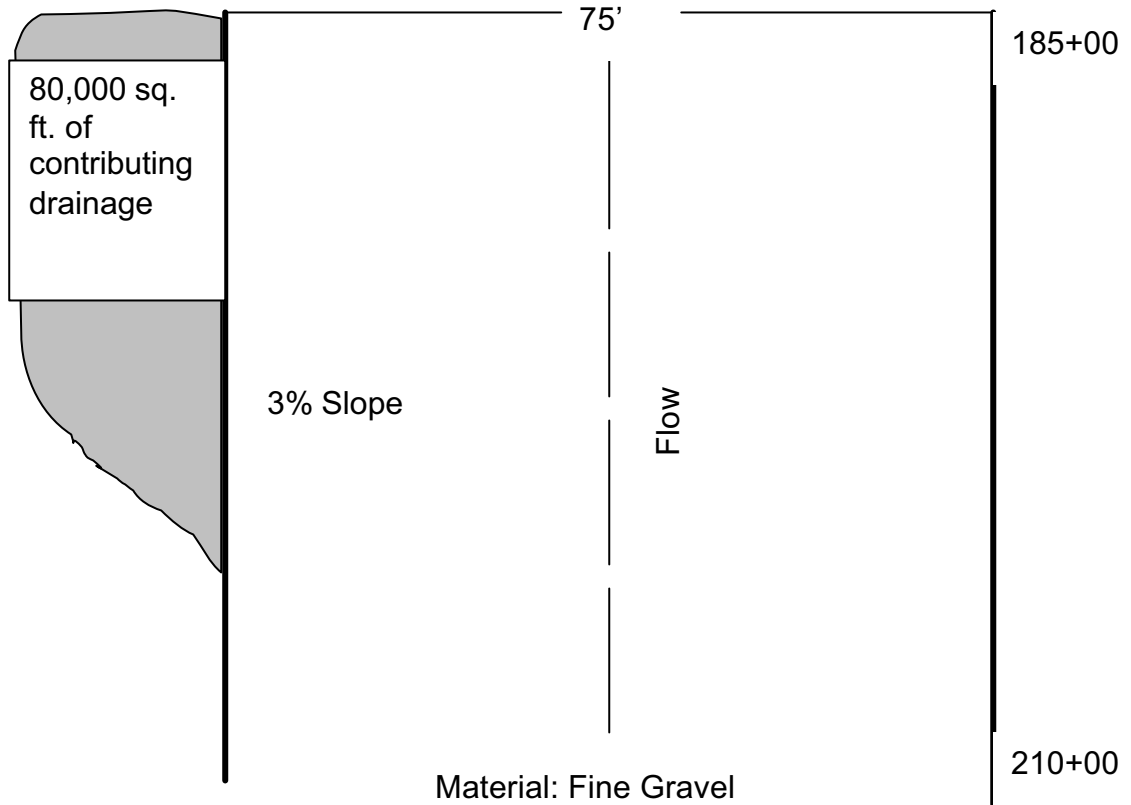

1. First we need to know the water velocity at station 210+00.

Drainage Area = Ditch Length (2500 ft.) x Width (75 ft.) = 187,500 sq. ft.

Using the Ditch Velocity Graph (Handouts 3 & 4) we find that the water velocity at station 210+00 is 4.8 f.p.s

2. Next we check the Permissible Velocities Table (Handout 4).

The soil material in the area is fine gravel. The allowable water velocity for fine gravel is 5.0 f.p.s.

So since the velocity at station 210+00 is only 4.8 f.p.s, this ditch area would not need erosion protection.

However, let's say that in the preceding situation, the plans failed to note 80,000 sq.ft. of outside drainage from an adjacent field, which will contribute to this ditch. Will this make any difference? \_\_\_\_\_

1. Re-check the velocity at station 210+00, taking the additional drainage area into account. It must be added to the already calculated area.

New drainage area = Original area + new area  
= 187,500 sq. ft. + 80,000 sq. ft.  
= 267,500 sq.ft

From the Velocity Graph:

New water velocity at station 210+00 is 5.3 f.p.s



2. This changes the picture. The ditch will now need some erosion protection because the additional drainage it must carry has put the water velocity over the maximum allowable.

To determine where the protection should be started, you have to check the velocity at points upstream until you find the place where the velocity becomes just enough to warrant protection.

## CHANNEL PREPARATION

---

After finding locations where ditch protection is needed, the channel must be prepared so the protection can be installed. Make sure that the shaping is done such that on completion the topsoil in the ditch equals that on the adjacent area.

At times there are no clearly defined channels where the water is to flow. Generally this will occur where the water is coming over the backslope or is flowing across a wide area such as in an interchange or a fill ditch section. In these instances the Contractor is required to construct a special ditch. When constructing a special ditch channel, make sure it is undercut enough to allow room for replacement of the topsoil.

**Figure 5.3** A Properly Prepared Channel



Both normal ditches and special ditches must be finished to a uniform cross section. All depressions must be filled and all jumps cut off to provide a smooth even surface on which to place the ditch protection. Small blade or disk is a good implement for constructing a ditch. A "V" ditch is better than trying to flatten a ditch too much. You must build a well-defined drainage.

The shaping for ditch protection should be carried out according to the standard specifications. This is done so there is a smooth unrestricted flow of the side drainage over the edges of the protection. Any material left from channel excavation must be drifted uniformly away from the channel edges. Make sure that all ridges or depressions adjacent to the channel are eliminated so the runoff will flow into the channel.

The shaping of the channel is the most important part of installing the erosion control blanket. If it is not shaped properly the water will not stay on top of the blanket and erosion will occur at the longitudinal edge or it will begin to undercut the blanket. The alignment must also be kept uniform. Don't let the centerline meander. As much as possible, use tangent sections connected by smooth curves. Changing the direction of

the flow of water in a short distance causes a turbulence that often times will tear out the protection. At times side channels must tie into the main channel.

**Figure 5.4** A Properly Shaped Channel



The flow from these side channels should enter at the least possible angle and never at more than 45 degrees. This will cut down on the turbulence that will help in keeping the protection from being torn out. When sod, gabions, or riprap are used for channel protection, the ditch must be undercut to allow the surface of the protection to blend evenly with the adjacent surface.

Shaping the channels and installing the ditch protection should be done as quickly as possible after the finish grading and topsoiling is completed. This will hold erosion problems to a minimum. When possible, this work should be completed prior to the seeding, fertilizing and mulching of adjacent areas.

Although the DOT prefers to have the ditch protection installed prior to work on adjacent areas, the Contractor may do this work afterwards. In fact, several Contractors prefer to disk, seed, fertilize, and where required, mulch these channels in conjunction with the work on adjacent areas. They must then be careful not to disturb the adjacent area while installing ditch protection. If you feel they have disturbed the adjacent area, you can require them to re-seed, re-fertilize, and re-mulch the damaged spots at their expense.

## **EROSION CONTROL BLANKET (SECTION 734)**

---

An erosion control blanket is a uniform web of interlocking fibers with netting on both sides. When called for in the plans, the erosion control blanket shall be used to prevent erosion in the ditches and on roadway slopes.

There are two general types of erosion blankets: standard and high velocity. Only blankets that are included on the departments approved products list shall be allowed. Blankets shall be installed according to the manufactures' recommendations.

Generally the plans will indicate the locations where the two types of blankets will be used. Generally, the Standard Erosion Control Blanket will be used in ditches with slopes 2% to 4.5%. On ditches of 4.5% to 8.5% of grades, Hi-Velocity Blankets should be used.

## Installation

Prior to installing the erosion control blanket, the area is to be seeded and fertilized using the same materials and rates specified on the plans for the adjacent areas. The soil is worked to a depth of at least one inch. After the soil has been worked, all rocks or clods over 1 1/2 inches in diameter and all other foreign material must be removed. If the Contractor broadcasts the seed and fertilizer, rather than using a drill, it must be raked or dragged to get the proper coverage.

In installing the erosion control blanket, the Contractor must be careful handling the material. A uniform distribution of fibers throughout each strip is needed. In some cases, either due to manufacturing or to handling, some areas of the strip will be lacking the necessary fibers. Generally a ball of fibers is left at the end of each roll. These can be saved and used to fill in the thin spots. If this isn't done, you can have them cut it out and replace it with blanket that will provide adequate protection.

The erosion control blanket shall be installed by starting at the upstream end of the channel. If there is a sharp change in the grade at the starting point, begin the protection about 5 to 10 feet upstream. This gives the water a chance to get onto the protection while its velocity is still relatively slow. It reduces the chance of the water undermining the beginning of the protection.

It is required that the first strip placed shall be centered over the ditch. This works fine when both sides of the ditch have the same slope. When slopes differ, you may have to shift the first strip slightly in order to keep the outside edge at approximately the same elevation.

**Figure 5.5**

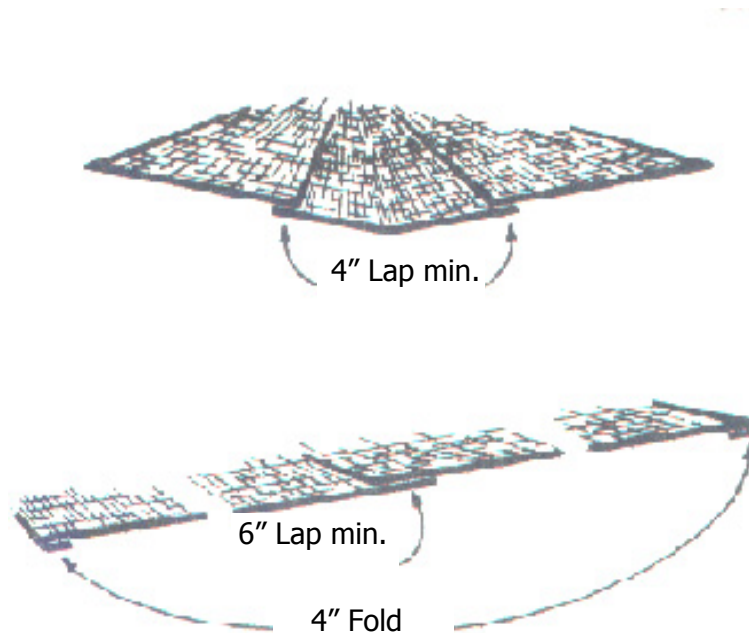

Where the width of protection is such that more than one strip of Erosion Control Blanket is required, the longitudinal edges shall be overlapped approximately 4 inches with the upslope strip on top. Successive longitudinal strips of erosion control blanket shall be overlapped approximately 6 inches with the upstream mesh being placed on top. The upslope end of the Erosion Control Blanket shall be buried in a trench that is 6" wide by 6" deep. The Erosion Control Blanket at the bottom of the protection is to be folded under approximately four inches before stapling.

**Figure 5.6** Properly Installed Erosion Control Blanket



Before anchoring the blanket, adjust it laterally in the channel to bring both edges to approximately the same elevation. In areas where the protection is being placed around a curve, the outside edge should be slightly higher than the inside edge.

The erosion control blanket is to be anchored according to manufacturer's recommendations. When anchoring the erosion control blanket, check to see that it is left in a somewhat loose condition. If it's stretched and drawn up tight, there won't be any give when the water flows across it which generally results in it being washed out.

**Figure 5.7** Incorrect Placement of Erosion Control Blanket



Note the water stain on the erosion control blanket. The erosion control blanket should have been placed more to the left of the photo so the water would flow in the center of the blanket.

**Figure 5.8** Excelsior Blanket Failure.



Inadequate anchoring can result in a complete failure of the system as noted in the picture above.

When the protection starts at a pipe or at some bank & channel protection baskets, it is to be installed to keep it from washing out. A trench about 6 to 8 inches deep must be dug across the width of the protection. Start each strip by placing it in the trench against the structure. Then backfill the trench. Make sure that all material is thoroughly tamped. You may need to add water to the material to get compaction.

**Figure 5.9** Properly Installed Blanket



After the erosion control blanket has been installed, check around the beginning and edges to see that they are properly shaped. Ridges or piles of dirt must be removed so the water can flow onto the protection rather than around it. This usually is handwork so you may have to remind the Contractor to get it done. The dirt can be drifted away from the protection or onto the edge of it. It doesn't matter as long as it is done smoothly.

## **MEASUREMENT AND PAYMENT**

---

Erosion control blanket will be measured to the nearest square yard. Erosion control blanket damaged from causes beyond the control of the Contractor shall be replaced and the replacement quantity added to the original quantities used.

Erosion control blanket will be paid for at the contract unit price per square yard. Payment will be full compensation for shaping and finishing ditches and channels, which are not specifically addressed with the item "ditch shaping", installing material and the furnishing of labor, equipment, staples, material, and incidentals necessary.

To document the amount of erosion control blanket being used, keep field notes for each location. For the notes, enter the stations where the blanket was placed, the length and width of blanket installed to calculate the square yards. As the field notes are the source document, they should be dated and signed. These quantities shall be entered into the Construction Measurement & Payment System.

## SOD (SECTION 733)

---

The sod the DOT uses must be Kentucky Bluegrass unless something else is specified in the plans. The sod can be obtained from a local or commercial source. When a commercial source supplies the sod, you can be fairly sure that you are getting Kentucky Bluegrass. If it comes from a local source, such as pasture, you may have to determine the type of grass. This can be done by looking at the tips of the leaves. Those on Kentucky Bluegrass are boat shaped and rounded on the ends whereas other grasses are more pointed. If you still are not sure, contact your County Agent.

**Figure 5.10** Grass diagram

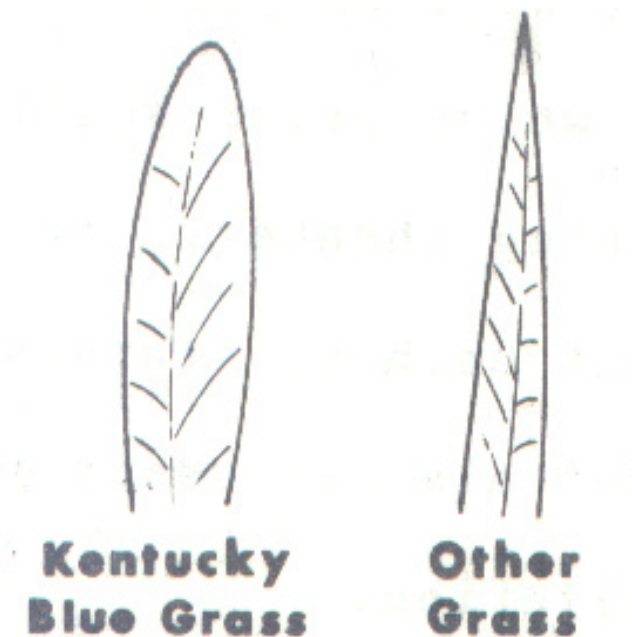

The sod is also required to be free from noxious weeds and substantially free of other objectionable grasses. To comply with this requirement, contact a County Agent or a Weed Supervisor from the area where the sod is to be obtained and ask them to determine if the sod is free of noxious weeds and objectionable grasses. If these people feel that it isn't, then it shouldn't be used. The sod must be moist before cutting so it can be rolled and handled without crumbling or breaking. If the sod crumbles and breaks up during placement, the root system has probably been damaged and you won't get a good growth of grass. It is up to the Contractor and/or the supplier to supply at their expense the water needed to moisten the sod before cutting.

**Figure 5.11 Strips of Sod**



In general, the sod shall be cut a depth of 3/4 inch. The actual cutting depth will vary from area to area and is dependent on the soil and the root system. We want the sod cut so most of the dense root system is retained within the strip and just showing on the bottom. You can check on the root system by picking away dirt. If you find a lot of fine roots, you are getting good sod. Another way to tell if you have most of the dense root system is to pick up sod by one end. If it doesn't tear apart, you probably have most of the root system. Sod cut too thin may not have enough roots left to keep the grass growing. When cut too thick, the roots may not grow through the surface on which it is placed, and it won't stay in place. Usually you don't need to worry about the sod being cut too thick. It is hard to cut and hard to handle because of the weight. If anything, it will be cut too thin.

All sod is to be in its final position within 36 hours after being cut. It is almost impossible to check on this requirement unless the sod is being cut locally. You can get an idea of the time since cutting by unrolling the sod and looking at the color of the grass. If it is turning yellow it is approaching the 36 hour limit. Advise the Contractor that he can lay it; but if it does not appear to be growing after three weeks, he must replace the unsatisfactory strips at his expense.

There are locations where the sod must be anchored to hold it in place. The anchoring is done by using "U" staples that are one inch wide by six inches long, made of No.11 or heavier ungalvanized wire.

## **SURFACE PREPARATION**

---

The surfaces to be sodded shall be constructed to the required cross section and contour and shall be smooth, uniform and free from stones, roots, and other undesirable foreign material. The surfaces shall be undercut to sufficient depth below adjacent areas so the top of the newly laid sod will be flush with any adjacent seeded or turfed areas and one inch below top of sidewalks, curbs, or other structures. Some trenching in of the areas to be sodded and some building up of the adjacent areas may be necessary. The adjacent areas shall smoothly blend with each other, without sharp breaks in the contours.



**Figure 5.12**

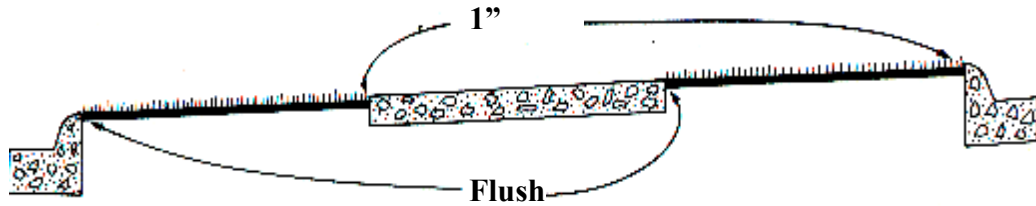

Just prior to placing the sod, the soil is to be worked for a depth of at least one inch to a fine texture. All clods and foreign material must be removed from the surface. Generally, these areas can be worked with equipment, but there will be areas where hand methods must be used. Following sod installation and just prior to watering, fertilize the sod at the specified rate.

If conditions are hot or dry, you can require watering before the sod is placed. A cool, moist bed gives the grass a better chance of surviving. It also caused the roots to start knitting to the bed faster. Generally, apply enough water to moisten the bed at least one inch. If tracking mud around while laying the sod becomes a problem, you should let the surface dry a little before going to work.

## **INSTALLATION**

All strips of sod shall be laid such that the end joints are staggered. This is done to reduce the number of seams. This is particularly important in waterways and on slopes. If all the joints fall at the same place, runoff could get under the whole area and wash it out. Care must be taken to ensure strips are butted snugly without overlapping. Gaps between strips must be covered with sod. If the overlapping and gaps are not repaired, the sod could be washed out by runoff during rain. All outside edges of a laid area are to be turned into the ground approximately two inches and covered with topsoil. The soil over the sod is to be compacted and smoothed to blend with the adjacent area.

**Figure 5.13**

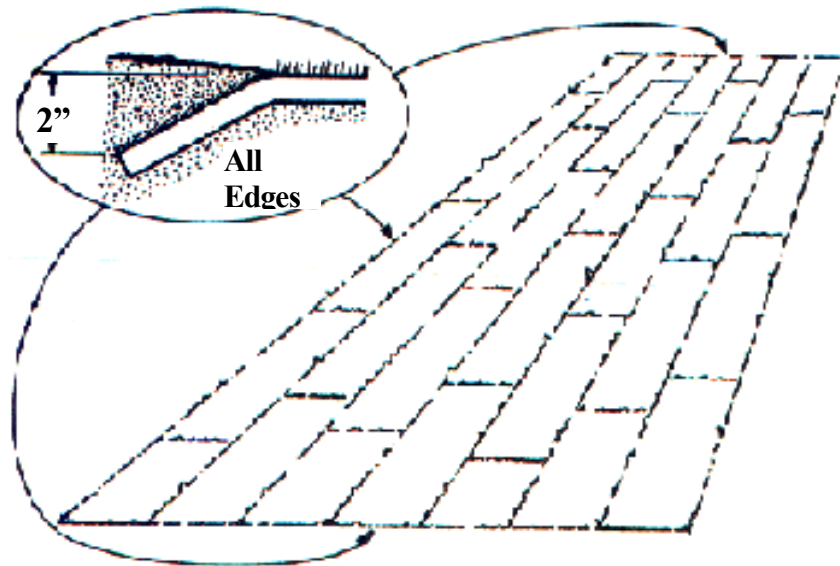

The only exception is this turning under is where the sod is butted to a solid surface such as curb or sidewalk. Sod placed in waterways must be laid so the strips are parallel to the flow. The placement must begin at the lower end with the strips being unrolled

uphill to reduce the possibility of stretching or tearing the strip and opening the end joint. Each sod strip is to be anchored on its upstream end with two "U" staples. The staples are to be driven flush with the sod surface.

**Figure 5.14**

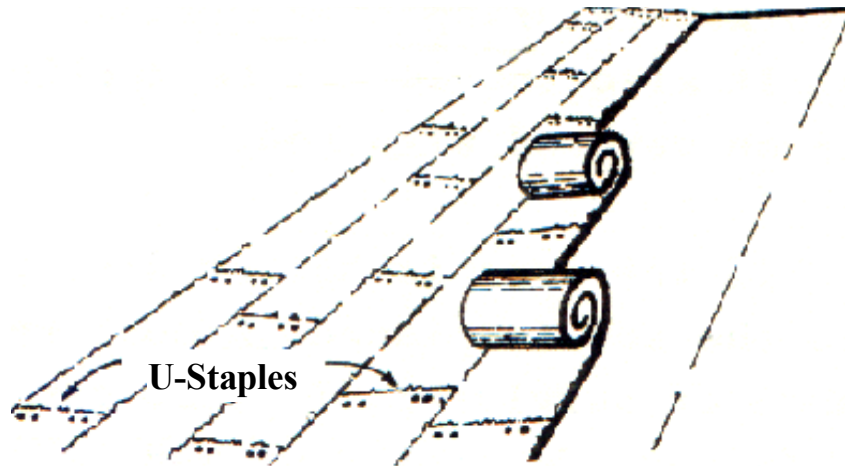

Place sod on a slope horizontally, beginning at the bottom. The strips are to be laid so the end joints are staggered. Care is to be taken to butt all strips smoothly to eliminate gaps and overlaps. On slopes steeper than 6:1 unless you feel there will be enough flow across the sod to cause damage. A minimum of 4 staples per sod strip in every other row should be used to hold the sod in place.

Sod should be watered twice a day for the first three days- preferably early morning and early evening. Then water only in the early morning until the end of week two. One-half inch of water should be applied during each watering. During weeks three and four, apply one inch of water every other day in the early morning. Water may need to be adjusted due to precipitation or extreme heat, but the roots need to be kept moist so that they are able to root into the soil. Avoid watering during the hottest times of the day. If any sod dies or is damaged during the watering, you may require it be replaced. Sod replaced must again be kept watered as above.

Figure 5.15

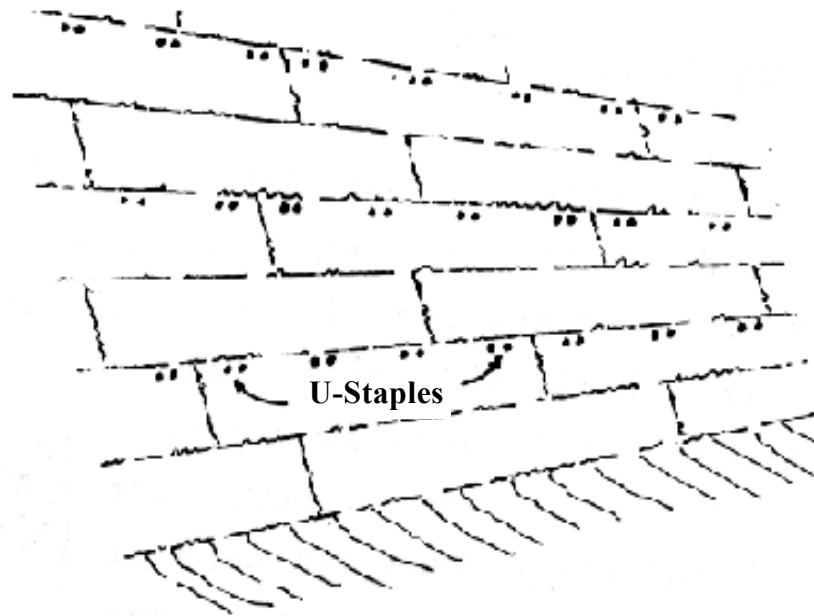

## MEASUREMENT AND PAYMENT

---

All sod is to be measured and documented in a field notebook or the Construction Measurement and Payment System. The measurements are to be taken on the sod surface and made to the nearest 0.1 foot. The field notes should give the location of the sodded area, a sketch showing all dimensions, and be dated and signed.

As sodded areas are generally odd-shaped, you need to take your measurements so you have the shapes. Usually this can be broken into rectangles, triangles or some portion of a circle that you can find the area. But to do this, you need to visualize what shapes you plan to use so you can get all needed measurements. In some cases, the area can't be broken into the common shapes for figuring.

Here are two formulas that can be used to figure odd areas:

Segments of a Circle:  $A = \frac{RD}{2}$

**Figure 5.16** Segment of a circle

EXAMPLE: A circular segment has Length of 17.6 feet.

$$\text{Area} = \frac{15.0 \text{ ft.} \times 17.6 \text{ ft.}}{2} = 132.0$$



**Figure 5.17** Odd Shaped Triangle

Odd Shaped Triangles:

$$\text{Area} = \sqrt{S(S-a)(S-b)(S-c)}$$

$$\text{Where } S = \frac{a+b+c}{2}$$

EXAMPLE: Find A

$$S = \frac{20.0' + 23.6' + 14.4'}{2} = 29.0 \text{ ft.}$$

$$A = \sqrt{29.0'(29.0' - 20.0')(29.0' - 23.6')(29.0' - 14.4')}$$

$$1 = \sqrt{29.0' \times 9.0' \times 5.4' \times 14.6'}$$

$$= \sqrt{20577.24} = 143.45 \text{ sq.ft.}$$

Figure 5.18 Odd Shaped Triangle

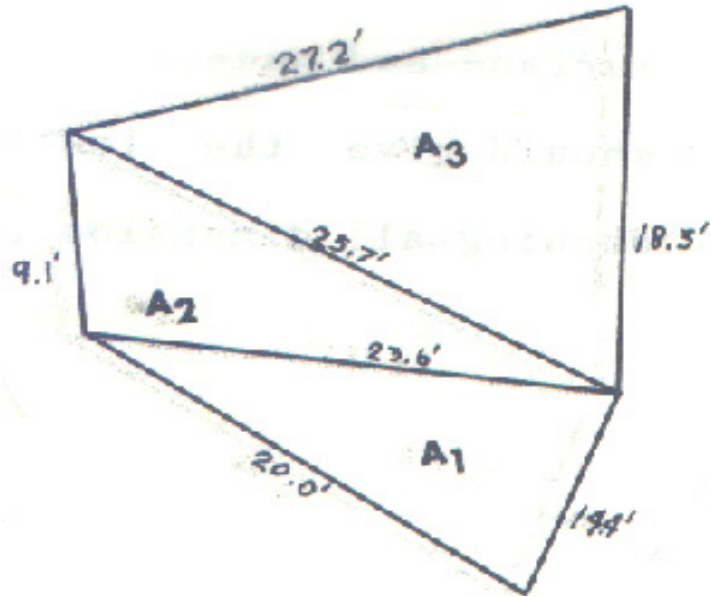

Although there are many calculations involved in this method, it is probably the most accurate way of finding the quantity for most odd shaped areas. It works especially well where sod is placed near bridge berms or where there are curves of varying radii.

Sod is paid for by the square yard to the nearest whole square yard. Figure the individual parts of each area to the nearest 0.01 square foot. Then total the parts and divide by 9 for square yards. Round this to the nearest square yard and you have the quantity that is to be paid for. The water is to be paid for as "Water for vegetation." It is to be measured by MGal and documented the same as it is for water for embankment. The fertilizer used is measured, paid for and documented the same as any other fertilizer.

What is the quantity of sod in the total area of the sketch shown in the last example?

---

## RIPRAP (SECTION 700)

---

**Figure 5.19** Example of RipRap used along channel and bridge berm.



Riprap is a layer of large rock placed on a slope for erosion protection. It is used when the velocities are greater than what the erosion control blanket or sod can withstand. It also is used where there is a continual wave action against the slope. Mostly it is used to protect bridge berms, but occasionally it is also used around inlets and outlets of pipe and in smaller drainage channels.

**Figure 5.20** Rock Check Dams



The material used for riprap can be either quarry rock or field stone, depending on the class of riprap. It must be hard and durable so it won't disintegrate when exposed to the water and weather. This is difficult to check.

Specifications require rock used for riprap to weight at least 155 pounds per cubic foot. Once you determine where the Contractor plans to get his riprap, grab a small rock and weigh it to determine if it meets this requirement.

The plans call for a certain class of riprap. This class defines the size of the material. A gradation specification for the various classes will also be given and will be similar to the following table.

Riprap Class	Rock Size in Feet	Rock Size in Pounds	Percent of Riprap Smaller than
A	1.30	200	100
	0.95	75	50
	0.40	5	15
B	1.80	500	100
	1.30	200	50
	0.40	5	15
C	2.25	1000	100
	1.80	500	50
	0.95	75	15
D	2.85	2000	100
	2.25	1000	50
	1.80	500	15
E	3.60	4000	100
	2.85	2000	50
	2.25	1000	15
F	4.50	8000	100
	3.60	4000	50
	2.85	2000	15

Top of Berm

Source: SD Standard Specifications for Roads & Bridges, 2004 Edition.

The riprap must be checked to see that it meets gradation. The Contractor is required to provide two samples of at least 5 tons each that meets the specified gradation. One sample is to be kept at the source and one at the construction site. By looking at these samples you should be able to determine if the riprap is acceptable. If you and the Contractor disagree on the acceptability of the riprap, you can require that two random truckloads be dumped and actually checked. The Contractor must supply the men and equipment needed to sort and weigh the rock.

## Installation

The plans and cross sections will show where the riprap is to be placed, the thickness and height desired. The locations and dimensions given are based on the assumption that construction will be as planned. If a change is made on construction that affects the channel width, slopes or grade or maybe increases or decreases the contributing drainage area, some changes in the riprap may be needed. Contact the Roadside Development Program for recommendations.

**Figure 5.21**

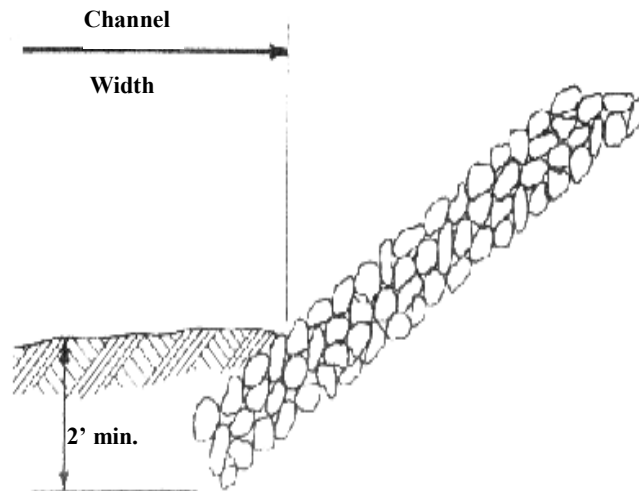

The area where riprap is to be placed must first be shaped to the required cross section. All brushes, stumps, trees, and junk must be removed. Soft spots are to be removed, backfilled and compacted. Unless shown otherwise in the plans, a trench must be built for the riprap toe. The DOT wants this toe ditch dug into solid ground such that the full thickness of the riprap will be below the channel flow line. Generally the plans will show the surface of the riprap being flush with the face of the channel slope. It must be built this way because the design was based on an open waterway. If the riprap is placed on the channel slope, the waterway is reduced which may cause an increase in depth or velocity, causing damage to the area.

The riprap is to be placed to full depth in one operation and not in lifts. Watch the placement closely to see that a uniform well-graded mass is obtained. Watch for segregation of sizes and voids. If this does occur, the method of placement will have to be changed. This might require some rearranging by hand or with equipment.

Probably the biggest problem with riprap is not placing large enough material. Then when we get a "gully washer," out goes the riprap with whatever it was suppose to protect. Don't let the Contractor talk you into using any pile of rock for riprap, unless you are certain that it meets the size required by the plans. If you aren't sure of the size, dump a load and have it checked.

When drainage fabric is specified on the plans to be placed under the riprap, the surface to be covered shall be smooth, free of obstructions, and shall conform to the plans shown in dimensions prior to placement of the drainage fabric.

## **Measurement and Payment**

---

Riprap can be measured for payment in tons to the nearest 0.1 ton or in cubic yards to the nearest 0.1 cubic yard. Usually plans show the quantity in tons. When they do, your documentation is a filled out weight ticket for each load. If the Contractor doesn't have a scale, a commercial scale ticket can be accepted if the scaleperson is bonded.

When the quantity calls for cubic yards, you can measure each truck box and figure the cubic yards it holds. Take the measurement to the nearest 0.1 foot. These measurements and volume computations are your source documentation and are to be put in a field notebook or CMPS system, dated and signed. Make sure that the loads are loaded the same each time.

Drainage fabric will be measured and paid for by the nearest square yard. The lap at joints will not be measured for payment.

# GABIONS (SECTION 1030)

---

Gabions are basically baskets made of wire mesh which are filled with rock. They are used where the water velocity will be greater than what the erosion control blanket or sod can withstand. Generally, the baskets are used for stream bank protection, ditch channel lining and at the ends of pipe.

**Figure 5.22** Gabions



The plans will show where the gabions are to be installed. The plans will also provide a typical section and plan view for the basket installation. The typical section is important to the Contractor, as this is the only way he can determine the size and number of gabions or amount of mesh to order. In some situations, the plans will call for a Geotextile Fabric Liner to be placed prior to and just below the gabions. This is done to keep the soil from washing out from below the gabions, especially in light, silty soils.

Before any of these prefabricated gabions can be used on the project, the Contractor must supply the Engineer with a Certificate of Compliance stating the wire mesh, wire ties and tie wires meet DOT specifications. When gabions are fabricated in the field you also need to have the material tested by the Central Testing Laboratory. Be sure that the Certificates, and where needed, acceptable test reports, are on file before using these materials.

Note: Soil conditions may warrant use of PVC coated bank and channel protection gabions. The Materials and Surfacing Office provides recommendations regarding need for PVC coated bank and channel protection gabions.

## Fabrication

---

Gabions can be supplied in a combination of dimensions; they are suppose to be 3 feet wide and can be either 6, 9, or 12 feet long and can be either 1 foot or 1'6" or 3' high. These are the dimensions shown on Standard Plate 720.01, but in reality they are nominal dimensions. Due to variations in mesh dimensions and methods of fabrication, the measurements will vary. You may consider the baskets acceptable if your measurements are within a couple of inches of what is specified in the plans.

Gabions are made from precut pieces to form a single unit in accordance with these typical sections. Generally the top, sides, ends and bottom will be attached when



delivered. As shown each basket has internal diaphragms to divide it into two or more cells. Regardless of how the other pieces are delivered, the diaphragms must be attached to the bottom section.

**Figure 5.23**

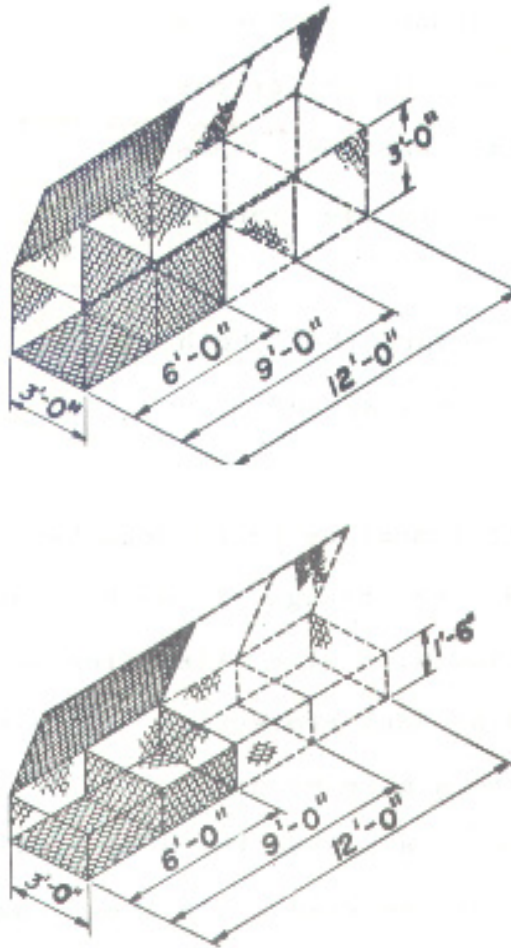

Before installation, each Gabion must be assembled to form an individual unit. All edges where the pieces come in contact must be bound together. They can be bound by lacing No. 9 wire through the mesh on about four inch centers or can be tied with wire ties on about 6 inch centers. When used as bank protection, it is probably best to use lacing due to a more secure connection. When the wire ties are used, be sure that both ends are twisted. If they just twist one end around the other, the tie can be pulled open very easily.

The hog ring type of connection is probably the most popular method because it's quicker. One must make sure that the hog ring is squeezed enough so it's a minimum of 1" overlap.

## Installation

---

Before gabions can be installed, assure that the excavation will not interfere with the utilities (SD One Call). How this is done is up to the Contractor, but you need to see that it is done in accordance with plan details. This is how the gabions are to be installed when used in a ditch channel. Notice that the outside edges are about 6 inches below

the normal slope. This ensures that the runoff will be directed onto the protection. There are several different sections used for ditch protection, so be sure you check your plans.

**Figure 5.24** Typical Section

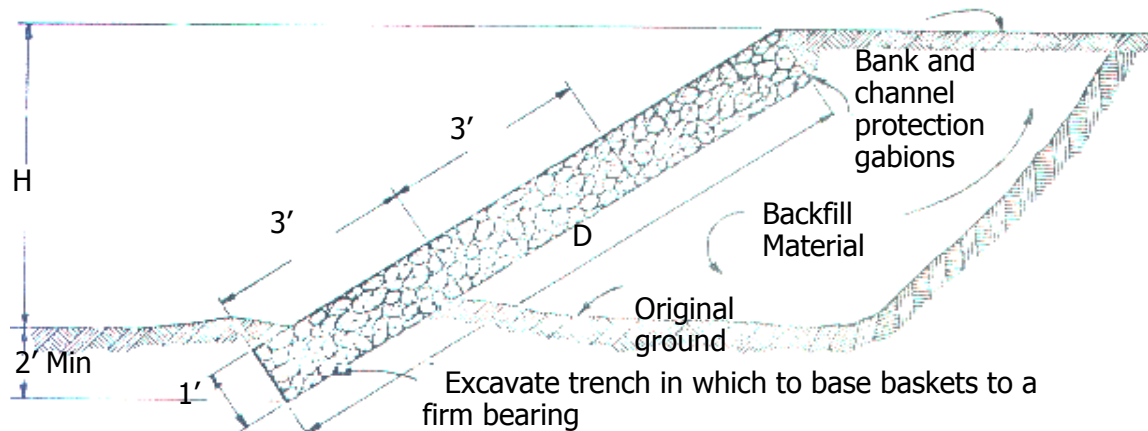

"D" and "H" - Distance variable depending on field conditions

The gabions should be installed for bank protection in a waterway as shown. It requires excavation and backfill. Make sure the backfill is compacted in accordance with the plans or specifications to provide a solid base for the gabions. Also be sure to get the toe down at least two feet below the flowline or as specified in the plans to stop the gabions from being under cut and washed out. When used for bank protection, the cross sections are drawn to show the finished face of the channel. This means the bank slopes must be underbuilt by the depth of the gabions to be placed. If they aren't, the waterway area will be reduced, which could cause a hydraulic problem.

**Figure 5.25** Gabions used in a Channel Application.



When used as ditch protection, the gabions at the beginning and end of each installation and approximately every 100 feet along the protection are to be installed vertically. This

cutoff wall keeps the gabions from being undermined and gives some additional longitudinal support. Although this is not required where gabions are used for bank protection, it can be done where a cutoff wall or longitudinal support is needed. In some cases, the Contractor will dig a trench for the gabions. At other times, he may dig out an area larger than needed. When this occurs, be sure they do a good job of compacting the back fill around the gabions or they could settle causing a dam and tearing some of the ties loose.

In addition to tying the edges, most gabions are required to have internal ties. These basically hold the Gabion in shape. The vertical wires are "C ties" and the horizontal wires are "D ties". All gabions used for ditch or bank protection are required to have four "C ties" uniformly spaced in each Gabion. If they are placed flat, such as for a jetty, each Gabion is required to have four "D ties" instead of the "C ties". "C ties" are not required for gabions. Gabion 1 1/2 feet high must have four "D ties" and those three foot high must have eight "D ties" (two rows about one foot apart). These "D ties" are only required on the outside cells. Also, the Area Engineer can delete them using gabions as slope protection.

Most Contractors use a small jig as shown to put in the "C ties". It holds wires in place while the Gabion is filled with rock. When the Gabion is full, the jig is pulled out, leaving the ties in place. When "D ties" are required, they fill the Gabion part way, put in the ties and then finish filling.

Gabions- They must be tied together along all edges using the same method of tying that was used for fabrication...lacing on four inch centers or ties on six inch centers.

When gabions are used at the outlets of pipe, they are to extend a maximum of two feet under the flared end. On concrete pipe this doesn't cause problems because the flared end will sit on the top of the Gabion. With metal pipe, there is a problem. The metal flared ends have a lip that sticks down about six inches. It is best to bend the lip back up under the flared end so it can be set flush on the Gabion. This gets it out of the way while still giving stiffness to the edge of the flared end.

**Figure 5.26** Gabions used at Pipe Outlet



Gabions used for jetties and ditch channels don't have any side support while being filled. Unless the Contractor uses care, this causes the sides to bulge. It then is almost impossible to get the lit to fit properly without doing some extra work. To eliminate the problem, some Contractors stake boards along the side of the gabions.

Occasionally there will be a place where a Gabion has to fit against or go around an existing feature, you will need to cut it to fit after it is in place, make sure that all the loose ends are tied off.

Gabions shall be filled with rock ranging in size from 4 to 8 inches in diameter. The majority of the stones shall be in the 5 to 6 inch range. The rock used can be either quarried or field stone, but must be hard and durable so it won't disintegrate when exposed to water or weather. You may have some difficulty telling if the material proposed for use meets this requirement. As soon as you find out what material the Contractor plans to use, grab a sample for testing and verify that it will meet the specifications. We want to make use of as much naturally available material as possible. The Contractor may have to do some screening and/or scalping to get the right sizes. If at all possible, you should get a uniform gradation between these sizes. Using all large rock will leave too many voids and makes a poor looking job. Using all small rock will give a good appearing job but they might also work through the mesh. Try to get as compact a mass as possible. This may require handwork to rearrange some rock, but you can require that it be done where necessary.

After the gabions are in place, tied together and filled with rock, the area needs to be backfilled. This is an important step. If the gabions are not backfilled properly, water will wash the dirt away leaving them high and dry. Be sure to be on location during the backfilling operation so you can assure a good job. The compaction must be at least equal to that of the surrounding ground. This may require use of mechanical tampers. Quite often the soil for backfill has been laying a long time and has dried out. If this is the case, you can require that water be added to the soil to help achieve compaction.

## **Measurement and Payment**

---

Bank and Channel Protection Baskets will be measured to the nearest tenth of a cubic yard. If a substitution is made, the dimensions of the baskets installed shall be equal to or greater than the dimensions shown on the plans. Payment will be based on plans quantity, unless changes are ordered in writing.

### **Basis of Payment**

Bank and Channel Protection Baskets will be paid for at the contract unit price. Payment will be full compensation for materials, including baskets, stone and filter blanket, equipment, labor and incidentals, including irregular shapes requiring trimming.

## **SILT FENCE (SECTION 734)**

---

In most applications, silt fence is placed downslope from a construction site or newly disturbed area to prevent eroded soils from being transported by runoff to the surrounding environment. Silt fence is fabric with small openings that allows water to pass through while retaining a majority of the sediment.

**Figure 5.27** Silt fence performing its intended function



The Contractor should provide certification that the fabric meets specifications prior to installing the fabric. Refer to SD Standard Specifications for Roads and Bridges for Silt Fence Specifications.

Silt fence should be installed before earth disturbing activities have begun. Location of the fabric is critical to its performance. Silt fences should be installed where it will capture sediment from the project before it leaves the project. It should not be installed across major creeks or streams because the fabric can not handle that kind of runoff. Silt fence often acts like a temporary dam which causes problems if the silt fence is placed too close to an outlet end of a pipe. The sediment will partially or completely plug these pipes causing a lot of problems. For this reason it is generally better to place silt fence at the inlet end of pipes.

Another thing to be aware of is that silt fence will also catch snow. Be careful of this when selecting the locations.

After the silt fence has been installed it is necessary for the Contractor to perform some maintenance on the fabric. Large amounts of sediment might need to be removed from the upstream side of the silt fence. This work is paid for as Mucking silt fence. Repair of silt fence might also need to be done. This might be necessary to make sure the silt fence still meets the installation requirements specified. This work as directed by the Engineer and is paid for as Repair Silt Fence. Removal of the silt fence should not be done until other sufficient erosion control methods are in place. This could be after the area was seeded and mulched, sod placed or some other erosion control item installed. If the seed doesn't grow fast enough the silt fence often shouldn't be removed by the Contractor. If the project is completed, the silt fence will have to be removed by DOT forces.

## **Installation**

---

The installation of the silt fence should be done according to specifications and the standard plates included in the plans.

## Measurement and Payment

---

Silt fence is paid for by the nearest foot.

Mucking silt fence is paid for by the nearest cubic yard.

Repair of silt fence is paid for by the nearest foot.

Removal of silt fence is paid for by the nearest foot.

**Figure 5.28** Silt Fence Protecting Channel from Sedimentation.



## ANSWERS TO MANUAL'S PROBLEMS

### Page 2-10

A) Handout 1 - Yes

Handout 2 - No

Washington is not in the area allowed

B) Yes

### Page 2-11

C) No

### Page 2-12

40.68 PLS

### Page 3-20

Yes (18.6), No

### Page 4-25

Under fertilized by 26.8%, make corrections and re-fertilize are.

### Page 5-38

1) 4.0

2) 3.7, Yes

3) 4.8, No

### Page 5-39

Yes

### Page 5-51

479.16 sq. ft. = 53 sq. yrds.

## **STANDARD PLATES**

On the following pages are the current Standard Plates for Erosion and Sediment Control.



