

Chapter 12

**STORM DRAINAGE SYSTEMS**

**SOUTH DAKOTA DRAINAGE MANUAL**

*October 2011*



## Table of Contents

<u>Section</u>	<u>Page</u>
12.1 OVERVIEW .....	12-1
12.1.1 Introduction.....	12-1
12.1.2 Inadequate Drainage .....	12-1
12.1.3 General Design Guidelines.....	12-2
12.1.4 Detention Storage.....	12-2
12.2 SYMBOLS AND DEFINITIONS .....	12-3
12.3 DEFINITIONS.....	12-5
12.4 GENERAL DESIGN APPROACH.....	12-7
12.4.1 Design Process .....	12-7
12.4.2 Location and Size Guidelines .....	12-7
12.4.3 Outfall Guidelines .....	12-8
12.4.4 Contributing Drainage Areas .....	12-8
12.4.5 Pipe Length Measurements.....	12-8
12.5 HYDROLOGY.....	12-9
12.5.1 Introduction.....	12-9
12.5.2 Design Frequency .....	12-9
12.5.3 Review Frequency.....	12-9
12.5.4 Rational Method .....	12-10
12.5.4.1 Introduction.....	12-10
12.5.4.2 Time of Concentration .....	12-10
12.6 ROADWAY GEOMETRICS .....	12-12
12.6.1 Introduction.....	12-12
12.6.2 Roadway Cross Section .....	12-12
12.6.2.1 Width .....	12-12
12.6.2.2 Cross Slope .....	12-13

**Table of Contents**  
(Continued)

<u>Section</u>	<u>Page</u>
12.6.3 Vertical Alignment.....	12-13
12.6.3.1 Longitudinal Slope .....	12-13
12.6.3.2 Vertical Curves .....	12-13
12.6.4 Curb and Gutter.....	12-14
12.6.5 Medians.....	12-14
12.7 WATER SPREAD.....	12-16
12.7.1 General.....	12-16
12.7.2 Selection.....	12-16
12.7.3 Allowable Water Spread .....	12-16
12.8 GUTTER FLOW CALCULATIONS .....	12-18
12.8.1 Introduction.....	12-18
12.8.2 Capacity Relationship.....	12-19
12.8.3 Uniform Cross Slope Procedure .....	12-20
12.8.4 Composite Gutter Section Procedure.....	12-21
12.9 INLETS.....	12-24
12.9.1 General.....	12-24
12.9.2 Types.....	12-24
12.9.2.1 Grate Inlets .....	12-24
12.9.2.2 Curb-Opening Inlets.....	12-25
12.9.2.3 Combination Inlets .....	12-25
12.9.2.4 Slotted Drain Inlets .....	12-25
12.9.3 Drop Inlets.....	12-26
12.10 INLET LOCATION, SPACING AND CAPACITY.....	12-27
12.10.1 General.....	12-27
12.10.1.1 Location .....	12-27
12.10.1.2 Spacing Process.....	12-27

**Table of Contents**

(Continued)

<b><u>Section</u></b>	<b><u>Page</u></b>
12.10.2 Grate Inlets on Grade .....	12-28
12.10.3 Grate Inlets In Sag.....	12-32
12.10.4 Curb Opening Inlets on Grade.....	12-36
12.10.5 Curb-Opening Inlets in Sag .....	12-38
12.10.6 Combination Inlet on Grade.....	12-41
12.10.7 Combination Inlet on Sag .....	12-42
12.10.8 Flanking Inlets .....	12-42
12.10.9 Inlet Spacing Computations.....	12-45
12.11 MANHOLES .....	12-49
12.11.1 Location.....	12-49
12.11.2 Spacing .....	12-49
12.11.3 Types.....	12-49
12.11.4 Sizing.....	12-50
12.11.4.1 Rectangular Junction Box Minimum Size .....	12-50
12.11.4.2 Circular Manhole Sizing Procedure .....	12-50
12.12 INITIAL SIZING OF STORM DRAINAGE SYSTEM .....	12-55
12.12.1 Introduction.....	12-55
12.12.2 Design Procedures.....	12-55
12.12.3 Sag Point.....	12-56
12.12.4 SDDOT Practices .....	12-59
12.12.4.1 Minimum Pipe Size .....	12-59
12.12.4.2 Material.....	12-59
12.12.4.3 Minimum Cover and Clearance .....	12-59
12.12.4.4 Joint Seals .....	12-59
12.12.4.5 Pipe-to-Inlet Connections .....	12-60
12.12.4.6 Storm Drainage Gradients.....	12-60
12.12.4.7 Insulation .....	12-61
12.12.5 Hydraulic Analysis .....	12-62
12.12.5.1 SDDOT Practices .....	12-62
12.12.5.2 Methodology .....	12-62

**Table of Contents**  
(Continued)

<b><u>Section</u></b>	<b><u>Page</u></b>
12.12.6 Minimum Grades .....	12-63
12.12.7 Curved Alignment.....	12-64
<b>12.13 HYDRAULIC GRADE LINE .....</b>	<b>12-65</b>
12.13.1 Introduction.....	12-65
12.13.2 SDDOT HGL Practices.....	12-65
12.13.3 Tailwater.....	12-67
12.13.4 Energy Losses.....	12-67
12.13.4.1 Exit Losses .....	12-67
12.13.4.2 Pipe Friction Losses .....	12-68
12.13.4.3 Bend Losses .....	12-68
12.13.4.4 Manhole/Inlet Losses Inlet.....	12-69
12.13.5 Hydraulic Grade Line Design Procedure .....	12-71
<b>12.14 URBAN WATER QUALITY PRACTICES .....</b>	<b>12-72</b>
<b>12.15 INVERTED SIPHONS .....</b>	<b>12-73</b>
<b>12.16 REFERENCES .....</b>	<b>12-74</b>

**List of Figures**

<b><u>Figure</u></b>		<b><u>Page</u></b>
Figure 12.2-A	SYMBOLS AND DEFINITIONS .....	12-4
Figure 12.7-A	ALLOWABLE WATER SPREAD FOR ROADWAYS .....	12-17
Figure 12.8-A	TYPICAL CURB AND GUTTER SECTIONS .....	12-18
Figure 12.8-B	MANNING’S n FOR GUTTERS (after HDS 3, Table 1 (Reference (5)) .....	12-19
Figure 12.10-A	GRATE INLET FRONTAL-FLOW INTERCEPTION EFFICIENCY (Reference (1)) .....	12-30
Figure 12.10-B	SPASH-OVER VELOCITY EQUATIONS.....	12-31
Figure 12.10-C	CURB OPENING INLETS.....	12-39
Figure 12.10-D	FLANKING INLETS AT SAG POINT .....	12-43
Figure 12.10-E	INLET SPACING COMPUTATION SHEET .....	12-48
Figure 12.11-A	MANHOLE SIZING BASED ON LEG ANGLE .....	12-50
Figure 12.11-B	DEGREES REQUIRED FOR PIPE OPENING (For Round and Arch Pipe).....	12-51
Figure 12.11-C	TYPICAL PLAN SECTION.....	12-52
Figure 12.12-A	FULL-FLOW CURVES, CIRCULAR PIPE, n = 0.012 .....	12-57
Figure 12.12-B	FULL-FLOW CURVES, ARCH PIPE, n = 0.012 .....	12-58
Figure 12.12-C	MINIMUM SLOPES NECESSARY TO ENSURE 3 fps IN STORM DRAINS FLOWING FULL (Equation 12.25).....	12-64
Figure 12.13-A	HYDRAULIC AND ENERGY GRADE LINE ILLUSTRATION .....	12-66
Figure 12.13-B	K <sub>M</sub> BASED ON STRUCTURE CONFIGURATION.....	12-69
Figure 12.13-C	DEFINITION SKETCH FOR HEC 22 (2009) MANHOLE LOSS METHOD .....	12-70





## Chapter 12

# STORM DRAINAGE SYSTEMS

### 12.1 OVERVIEW

#### 12.1.1 Introduction

This Chapter provides guidance on all elements of storm drainage design: system planning, pavement drainage, gutter flow calculations, inlet spacing, pipe sizing and hydraulic grade line calculations. The quality of the final in-place system usually reflects the attention provided to every aspect of the design and to the construction and maintenance of the facility.

The design of a drainage system should address the needs of the traveling public and those of the local community through which it passes. The drainage system for a roadway traversing an urban area is more complex than for roadways traversing sparsely settled rural areas. This is due to:

- the wide roadway sections, flat grades (both in longitudinal and transverse directions), shallow water courses and absence of side channels;
- the more costly property damage that may occur from ponding of water or from flow of water through built-up areas; and
- the roadway section must carry traffic but also act as a channel to convey the water to a disposal point. Unless proper precautions are taken, this flow of water along the roadway may interfere with or possibly halt the passage of highway traffic.

#### 12.1.2 Inadequate Drainage

The most serious effects of an inadequate storm drainage system are:

- damage to adjacent property, resulting from water overflowing the roadway curbs and entering such property;
- risk and delay to traffic caused by excessive ponding in sags or excessive spread along the roadway; and
- weakening of the base and subgrade due to saturation from frequent ponding of long duration.

### 12.1.3 General Design Guidelines

A storm drain is defined as that portion of the storm drainage system that receives runoff from inlets and conveys the runoff to some point where it is then discharged into a channel, water body or piped system. A storm drain may be a closed-conduit, open-conduit or some combination of the two. They may be designed with consideration for future development, if appropriate. A higher design frequency (or return interval) should be used for storm drain systems located in a major sag vertical curve to decrease the depth of ponding on the roadway and bridges and potential inundation of adjacent property. Where feasible, the storm drains should be designed to avoid existing utilities. Attention should be provided to the storm drain outfalls to ensure that the potential for erosion is minimized. Drainage system design should be coordinated with the proposed staging of large construction projects to maintain an outlet throughout the construction project.

This Chapter discusses SDDOT design guidelines for storm drainage design and analysis, which are based on [HEC 22 \(Reference \(1\)\)](#). For additional guidance, refer to the AASHTO *Highway Drainage Guidelines*, Chapter 9 ([Reference \(2\)](#)).

### 12.1.4 Detention Storage

The reduction of peak flows can be achieved by the storage of runoff in detention basins, storm drainage pipes, swales and channels, and other detention storage facilities. These should be considered where existing downstream conveyance facilities are inadequate to accommodate peak-flow rates from highway storm drainage facilities. In many locations, the SDDOT, local highway agencies and/or developers are not permitted to increase runoff when compared to existing conditions, thus necessitating detention storage facilities. A dditional benefits may include the reduction of downstream pipe sizes and the improvement of water quality by removing sediment and/or pollutants. See [Chapter 13 "Storage Facilities"](#) for a discussion on detention storage.

## 12.2 SYMBOLS AND DEFINITIONS

To provide consistency within this Chapter, the symbols in [Figure 12.2-A](#) will be used. These symbols have been selected because of their wide use in storm drainage publications.

Symbol	Definition	Units
A	Area of cross section	sq ft
A	Watershed area	ac
$A_g$	Clear opening area of grate	sq ft
a	Depth of depression	in
C	Runoff coefficient or coefficient	—
$C_o$	Orifice coefficient	—
$C_w$	Weir coefficient	—
d	Depth of gutter flow at the curb line	ft
D	Diameter of pipe	ft
E	Efficiency of an inlet	percent
$E_o$	Ratio of frontal flow to total gutter flow ( $Q_w/Q$ )	—
g	Acceleration due to gravity	ft/sec <sup>2</sup>
h	Height of curb-opening inlet	ft
H	Head loss	ft
i	Rainfall intensity	in/hour
K	Coefficient	—
$K_M$	Adjusted loss coefficient	—
$K_u$	Unit conversion factor or coefficient	—
L	Length of curb-opening inlet or grate inlet	ft
L	Pipe length	ft
L	Length of runoff travel	ft
n	Roughness coefficient in Manning's formula	—
P	Perimeter of grate opening, neglecting bars and side against curb	ft
Q	Rate of discharge in gutter	cfs
$Q_b$	Bypass flow	cfs
$Q_i$	Intercepted flow	cfs
$Q_s$	Gutter capacity above the depressed section	cfs
$Q_T$	Total flow	cfs
$Q_w$	Gutter capacity in the depressed section	cfs
R	Hydraulic radius	ft
$R_f$	Ratio of frontal flow intercepted to total frontal flow	—
$R_s$	Ratio of side flow intercepted to total side flow	—
S or $S_x$	Pavement cross slope	ft/ft
S or $S_L$	Longitudinal slope of pavement	ft/ft
$S_e$	Equivalent cross slope	ft/ft
$S_w$	Depressed section slope	ft/ft
T	Top width of water surface (spread on pavement)	ft
$t_c$	Time of concentration	min
$T_s$	Spread above depressed section	ft
V	Vehicle speed	mph
V	Velocity of flow	fps
$V_o$	Gutter velocity where splash-over first occurs	fps
W	Width of gutter	ft
x	Distance to flanking inlets from sag point	ft
y	Depth of flow in approach gutter	ft

Figure 12.2-A — SYMBOLS AND DEFINITIONS

### 12.3 DEFINITIONS

The following definitions are important in storm drainage analysis and design. These definitions will be used throughout this Chapter to address different aspects of storm drainage analysis:

1. Combination Inlet. A drainage inlet usually composed of a curb-opening inlet and a grate inlet.
2. Crown. The crown, sometimes known as the soffit, is the top inside of a pipe.
3. Curb-Opening. A drainage inlet consisting of an opening in the roadway curb.
4. Drop Inlet. A box that is sized to match the storm drainage pipe and provides a base for the grate frame.
5. Equivalent Cross Slope. An imaginary straight cross slope having conveyance capacity equal to that of the given compound cross slope.
6. Flanking Inlets. Inlets placed upstream and on either side of an inlet at the low point in a sag vertical curve. These inlets intercept debris as the slope decreases and act in relief of the inlet at the low point.
7. Frontal Flow. The portion of the flow that passes over the upstream side of a grate.
8. Grate Inlet. A drainage inlet composed of a grate in the roadway section or at the roadside in a low point, swale or channel.
9. Grate Perimeter. The sum of the lengths of all sides of a grate, except that any side adjacent to a curb is not considered a part of the perimeter in weir-flow computations.
10. Gutter. That portion of the roadway section adjacent to the curb used to convey stormwater runoff. A composite gutter section consists of the section immediately adjacent to the curb, which has a cross slope steeper than the adjacent pavement, and the parking lane, shoulder or pavement at a cross slope of a lesser amount. A uniform gutter section has one constant cross slope.
11. Hydraulic Grade Line. The locus of elevations to which the water would rise in successive piezometer tubes if the tubes were installed along a pipe run (pressure head plus elevation head). It is also equal to the energy grade line minus the velocity head.
12. Inlet Efficiency. The ratio of flow intercepted by an inlet to total flow in the gutter.
13. Invert. The inside bottom of the pipe.

14. Lateral Line. A lateral line, sometimes referred to as a lead, has inlets connected to it but has no other storm drains connected. It is usually 24 in or less in diameter and is a tributary to the trunk line.
15. Pressure Head. Pressure head is the height of a column of water that would exert a unit pressure equal to the pressure of the water.
16. Bypass. Carryover flow that bypasses an inlet on grade and is carried in the street or channel to the next inlet downgrade. Inlets can be designed to allow a certain amount of bypass for one design storm and larger or smaller amounts for other storms.
17. Sag Point/Major Sag Point. A low point in a vertical curve. A major sag point refers to a low point that can overflow only if water can pond to a depth of 2 ft or more.
18. Side-Flow Interception. Flow that is intercepted along the side of a grate inlet, as opposed to frontal interception.
19. Slotted Drain Inlet. A drainage inlet composed of a continuous slot built into the top of a pipe that serves to intercept, collect and transport the flow.
20. Storm Drain. A storm drain is a closed or open conduit that conveys stormwater that has been collected by inlets to an adequate outfall. It generally consists of laterals or leads and trunk lines or mains. Culverts connected to the storm drainage system are considered part of the system.
21. Splash-Over. That portion of frontal flow at a grate that skips or splashes over the grate and is not intercepted.
22. Spread. The width of stormwater flow measured laterally from the roadway curb.
23. Trunk Line. A trunk line is the main storm drain line. Lateral lines may be connected at inlet structures, manholes or with pipe tees. A trunk line is sometimes referred to as a "main."
24. Velocity Head. A quantity proportional to the kinetic energy of flowing water expressed as a height or head of water ( $V^2/2g$ ).

## 12.4 GENERAL DESIGN APPROACH

### 12.4.1 Design Process

The design of a storm drainage system is a process that evolves as a project develops. The primary elements of this process are listed below in a general sequence by which they may be implemented:

- coordinate with other agencies (see [Section 4.2](#));
- collect data (see [Chapter 5 “Data Collection”](#));
- prepare preliminary layout;
- determine inlet location and spacing (see [Section 12.10](#));
- plan layout of storm drainage system:
  - + locate main outfall,
  - + determine direction of flow,
  - + locate existing utilities,
  - + locate connecting mains, and
  - + locate manholes;
- size the pipes (see [Section 12.12](#)) and manholes (see [Section 12.11](#));
- review hydraulic grade line (see [Section 12.13](#));
- prepare the plan; and
- provide documentation (see [Chapter 6 “Documentation of Hydraulic Studies”](#)).

### 12.4.2 Location and Size Guidelines

Storm drain pipes should not decrease in size in a downstream direction regardless of the available pipe gradient.

Locate the storm drain to avoid conflicts with utilities, foundations or other obstacles. Coordination with utility owners during the design phase is necessary to determine if an adjustment to the utilities or the storm drainage system is required. The location of the storm drain may affect construction activities and phasing. The storm drain should be located to minimize traffic disruption during construction. Minimizing the depth of the storm drain may produce a significant cost savings. Dual trunklines along each side of the roadway may be used in some cases where it is difficult or more costly to install laterals. Temporary drainage measures may be needed to avoid increases in flood hazards during construction.

### 12.4.3 Outfall Guidelines

The outfall of the storm drainage system is a key component that should accommodate the hydraulic demands and physical characteristics of the system. The identification of an appropriate system outfall includes the following considerations:

- the availability of the channel and associated right-of-way or easement,
- the profile of the existing or proposed channel or conduit,
- the flow characteristics under flood conditions, and
- the land use and soil type through the area of the channel.

Whether the outfall is enclosed in a conduit or is an open channel, the design flows should be conveyed without causing significant risk to the highway and surrounding property.

Because the outfall must be available for the life of the system, SDDOT should have access to all parts of the outfall for maintenance and to ensure adequate operation of the drainage system. This may require that a drainage easement be purchased through private property.

### 12.4.4 Contributing Drainage Areas

In previous upstream developed areas, the contributing drainage area will generally be limited to approximately one block either direction of the State Highway for determining drop inlet locations and pipe sizing of the storm sewer system. Any additional contributing drainage area beyond this distance can be designed into the State Highway storm drainage system, however by agreement the Local Governing Agency will be required to reimburse the State for any additional cost to upsize the storm drainage system along the State Highway.

In circumstances where upstream drainage areas are either undeveloped or has a natural water course that approaches the State Highway, the drainage will be accommodated based on proper year design storm according to [Figure 7.6-A](#).

### 12.4.5 Pipe Length Measurements

When pipe is installed between drop inlet and/or manholes requires that a section be cut, the pipe will be measured from the structure inside wall to inside wall and payment of pipe shall be rounded up to the nearest two feet in all cases.



## 12.5 HYDROLOGY

### 12.5.1 Introduction

[Chapter 7 “Hydrology”](#) discusses SDDOT’s practices with respect to hydrology. This Section discusses the application of the Department’s hydrologic practices specifically to storm drainage systems.

### 12.5.2 Design Frequency

[Figure 7.6-A](#) summarizes SDDOT practices for selecting the design frequency for various drainage appurtenances. The following applies to storm drainage systems:

- The typical design frequency is 10 years.
- If a storm drain provides the outlet for a cross drain, then the design frequency of the cross drain should be used for the storm drainage system downstream from the cross drain inlet.
- If local drainage facilities and practices have provided storm drains of lesser standard, to which the highway system should connect, provide special consideration to whether it is realistic to design the highway system to a higher standard than available outlets.
- For major sag points on Interstate, US and State highways, the design frequency should be 50 years where water can pond 2 ft deep or more on the travel lane and where projected 2-way ADT is greater than 5000.
- With storm drainage systems a risk analysis can be made to see if a five-year storm would be the more appropriate storm design frequency. Also, check with local officials to see if local ordinances require different frequencies to be designed for or analyzed.

### 12.5.3 Review Frequency

The typical review frequency is 100 years when it is determined that larger storm event flows should be evaluated.

Review of larger storm events should be evaluated for critical areas where flow or ponding of water can cause property damage or risk and delay of traffic. This includes review of the flow pathways where surface water not collected by the storm drainage system will be carried and outlet in a major drainage way. [Section 7.6.2.3](#) and [Section 12.1.1 through Section 12.1.3](#) include discussion concerning this.

## 12.5.4 Rational Method

### 12.5.4.1 Introduction

The Rational Method is the most common method used for the design of storm drains when the peak-flow rate is desired. Its use should be limited to systems with drainage areas of 200 ac or less. Drainage systems involving detention storage and pumping stations require the development of a runoff hydrograph.

[Section 7.13](#) discusses SDDOT's application of the Rational Method, which involves:

- the selection of a runoff coefficient (see [Section 7.13.5](#)),
- the time of concentration (see [Section 7.13.6](#)), and
- the rainfall intensity (see [Section 7.13.7](#)).

Of the variables in the Rational Method, only the time of concentration requires elaboration specifically for its application to storm drainage systems. See the following Section.

### 12.5.4.2 Time of Concentration

#### 12.5.4.2.1 Introduction

The time of concentration is defined as the time required for water to travel from the most hydraulically distant point of the watershed to the point of the storm drainage system under consideration. The designer is usually concerned with two different times of concentration — one for inlet spacing and the other for pipe sizing. There is a major difference between the two times, as discussed in the following Sections.

#### 12.5.4.2.2 Inlet Spacing

The time of concentration ( $t_c$ ) for inlet spacing is the time for water to flow from the hydraulically most distant point of the drainage area to the first upstream inlet, which is known as the inlet time. Usually, this is the sum of the time required for water to move across the pavement or overland in back of the curb to the gutter, plus the time required for flow to move through the length of gutter to the inlet. For pavement drainage, when the total time of concentration to the upstream inlet is less than five minutes, a minimum  $t_c$  of five minutes should be used to estimate the intensity of rainfall. The time of concentration for the second downstream inlet and each succeeding inlet should be determined independently, the same as the first inlet. For a constant roadway grade and relatively uniform contributing drainage area, the time of concentration for each succeeding inlet should also be constant.

#### 12.5.4.2.3 Pipe Sizing

The time of concentration for pipe sizing is defined as the time required for water to travel from the most hydraulically distant point of the watershed to the point of the storm drainage system under consideration. In these applications, time of concentration generally consists of two components:

- the time to flow to the inlet, which can consist of sheet flow, shallow concentrated flow and channel or gutter flow segments, and
- the time to flow through the storm drain to the point under consideration.

However, some NRCS Curve Number methods combine segments into a single lag time that is then empirically related to an overland time of concentration.

The sheet flow time of concentration segment is typically developed using the kinematic wave approach. The NRCS velocity equation provides a means to compute sheet flow and shallow concentrated flow travel time segments (see [Section 7.13.6.4](#)). Channel and storm drain times of concentration can be developed using Manning's equation or the HEC 22 ([Reference \(1\)](#)) triangular gutter approach.

#### 12.5.4.2.4 Summary

To summarize, the time of concentration for any point on a storm drain is the inlet time for the inlet at the upper end of the line plus the time of flow through the storm drain from the upper end of the storm drain to the point in question. In general, where there is more than one source of runoff to a given point in the storm drainage system, the longest  $t_c$  is used to estimate the intensity ( $i$ ).

## 12.6 ROADWAY GEOMETRICS

### 12.6.1 Introduction

This Section discusses the role of roadway geometrics on pavement drainage applicable to the hydraulic design of storm drainage systems. Where applicable, the discussion extracts information from or references the [SDDOT Road Design Manual \(Reference \(3\)\)](#). This Section does not discuss the following pavement drainage considerations:

1. Bridge Decks. [Chapter 14 “Bridge Hydraulics”](#) presents SDDOT practices for bridge deck drainage.
2. Roadside Channels. On roadway sections with open drainage and roadside channels, see [Chapter 9 “Roadside Channels”](#) for SDDOT practices.
3. Fill Slopes. Fill slopes should be designed to prevent erosion. In some cases, shoulder gutter and/or curbs may be necessary to channel drainage away from fill slopes especially susceptible to erosion. Chapter 7 “Cross Sections” of the [SDDOT Road Design Manual \(Reference \(3\)\)](#) presents SDDOT practices on the design of fill slopes.

Roadway geometric features that impact gutter, inlet and pavement drainage for storm drainage systems include:

- roadway width and cross slope,
- vertical alignment,
- curb and gutter sections, and
- presence of median barriers.

The pavement width, cross slope and profile control the time it takes for stormwater to drain to the gutter section. The gutter cross section and longitudinal slope control the quantity of flow that can be carried in the gutter section. Each of these is discussed in the following Sections.

### 12.6.2 Roadway Cross Section

#### 12.6.2.1 Width

In general, the wider the roadway width (i.e., traveled way plus shoulder/curb offset width), the greater the quantity of water that can be accommodated by the curb and gutter storm drainage system. See Chapter 7 “Cross Sections” of the [SDDOT Road Design Manual \(Reference \(3\)\)](#) for SDDOT roadway width criteria.

### 12.6.2.2 Cross Slope

The pavement cross slope is a compromise between the need for reasonably steep cross slopes for drainage and relatively flat cross slopes for driver comfort. The *AASHTO Green Book* ([Reference \(4\)](#)) notes that cross slopes of 2% have little effect on driver effort in steering, especially with power steering, or on friction demand for vehicular stability.

Chapter 7 “Cross Sections” of the *SDDOT Road Design Manual* ([Reference \(3\)](#)) presents the Department’s typical practice for cross slopes. SDDOT has adopted the following typical cross slopes on tangent sections of highways:

- Portland Cement Concrete: 2%
- Asphalt Concrete: 2%
- Other Asphalt Surfacing: 2%
- Gravel: 3%

### 12.6.3 Vertical Alignment

#### 12.6.3.1 Longitudinal Slope

A minimum longitudinal gradient is more important for a curbed pavement than for an uncurbed pavement because of the impact on the spread of stormwater against the curb.

Desirable longitudinal gutter grades should not be less than 0.5% for curbed pavements with an absolute minimum of 0.3% allowed on high-type pavements adequately crowned. Minimum grades can be maintained in very flat terrain by use of a rolling profile.

#### 12.6.3.2 Vertical Curves

Chapter 6 “Vertical Alignment” of the *SDDOT Road Design Manual* ([Reference \(3\)](#)) presents SDDOT’s practices for the design of crest and sag vertical curves. However, on curbed roadways, drainage considerations become important. The following presents SDDOT practices:

1. Sag Vertical Curves. On curbed facilities, sag vertical curves should be sufficiently “sharp” to prevent inadequate drainage near the bottom of the vertical curve. This can be achieved by designing the sag vertical curve to provide a minimum longitudinal gradient of 0.3% at the two points 50 ft from the bottom. This yields a maximum value of  $K = 167$  for the vertical curve, which is typically called the drainage maximum.

See [Section 12.10.8](#) for SDDOT practices on the use of flanking inlets at sag vertical curves.

2. Crest Vertical Curves. Drainage considerations are not as critical on crest vertical curves as sag vertical curves. However, good design practice is to design crest vertical curves based on a maximum  $K = 167$ .

#### **12.6.4 Curb and Gutter**

Curbing at the outside edge of pavements is used extensively on urban highways and streets. Curbs serve several purposes, including containing the surface runoff within the roadway and away from adjacent properties, preventing erosion, providing pavement delineation and enabling the orderly development of property adjacent to the roadway. See the [SDDOT Standard Plates](#) for typical curb and gutter sections used by the Department.

A curb and gutter forms a triangular channel that can be an efficient hydraulic conveyance facility to transport runoff of a lesser magnitude than the design flow without interruption to traffic. When a design storm flow occurs, there is a “spread” or widening of the conveyed water surface. The water spread includes, not only the gutter width, but also parking lanes or shoulders and portions of the traveled way. This is the width the designer is most concerned with in curb and gutter flow, and limiting this width becomes a critical design criterion. [Section 12.7.3](#) discusses the allowable water spread.

#### **12.6.5 Medians**

Medians are commonly used to separate opposing lanes of traffic on divided highways. It is preferable to slope median areas and inside shoulders to a center depression to prevent drainage from the median area from running across the traveled pavement. The following applies to surface drainage considerations on facilities with medians that are not depressed:

1. Flush Medians. Flush medians consist of a relatively flat paved area separating the traffic lanes with only painted stripes on the pavement. Flush medians should be either slightly crowned to avoid ponding of water in the median area or slightly depressed (with median drains) to avoid carrying all surface drainage across the travel lanes.
2. Curbed Medians. Curbed, raised medians are most commonly used on lower-speed urban arterials. The roadway is typically crowned to transport a portion of the pavement drainage to the outside and a portion to the median, which then requires a collection and conveyance system for the median drainage.

3. Median Barriers. With narrow medians on high-speed facilities (e.g., Interstates), a median barrier may be used to prevent out-of-control vehicles from crossing into opposing traffic lanes. When median barriers are used, it is necessary to provide inlets, especially on horizontal curves with superelevation, and connecting storm drains to collect the water that accumulates against the barrier.

## 12.7 WATER SPREAD

### 12.7.1 General

The top width of the open channel flow in the gutter is considered the spread. In general, the water spread should be limited to a specified width for the selected design frequency (see [Section 12.7.3](#)). For storms of greater magnitude, the spread can be allowed to use most of the pavement as an open channel. For multilane curb and gutter, or guttered roadways with no parking, it is not practical to avoid travel lane flooding when longitudinal grades are flat (0.2% to 1%).

### 12.7.2 Selection

The major consideration for selecting a design water spread is highway classification, because this reflects public expectations for encountering water on the pavement surface. For example, ponding should be minimized on the traffic lanes of high-speed, high-volume highways where it is not expected. Highway speed is another major consideration because, at speeds greater than 45 mph, even a shallow depth of water on the pavement can cause hydroplaning. Other considerations include inconvenience, hazards and nuisances to pedestrian traffic and buildings adjacent to roadways that are located within the splash zone. In some locations (e.g., commercial areas), these considerations may assume major importance.

### 12.7.3 Allowable Water Spread

[Figure 12.7-A](#) summarizes SDDOT practices for maximum allowable water spread on roadways at the selected design frequency based on the type of facility. See [Section 14.7.3.6](#) for allowable water spread on bridge decks.

The spread width may be adjusted if warranted by an assessment of the costs vs. risks. If the above spread requirement results in very close inlet spacing (i.e., 100 ft or less), then alternative drainage interceptors could be considered. This may include allowing the spread to cover the outside lanes of a roadway with four lanes or more depending on the project conditions.



Type of Facility	Number of Lanes	Design Speed (mph)	Allowable Water Spread
Interstate	Any	Any	Gutter & Shoulder
US and State Highways, Local Roads, Ramps	2	Any	Gutter & Shoulder <sup>1</sup>
	3 or more	≤ 40	Gutter, Shoulder & ½ Driving Lane
	3 or more	≥ 45	Gutter & Shoulder <sup>1</sup>

## Notes:

A parking lane is considered to be included with the shoulder width where applicable. For wide parking lanes, the allowable water spread should be limited so that water does not rise above the curb.

<sup>1</sup> These criteria apply to shoulder widths of 6 ft or greater. Where shoulder widths are less than 6 ft, a minimum allowable water spread of 8 ft from the curb should be considered.

**Figure 12.7-A — ALLOWABLE WATER SPREAD FOR ROADWAYS**

## 12.8 GUTTER FLOW CALCULATIONS

### 12.8.1 Introduction

Gutter flow calculations are necessary to relate the quantity of flow ( $Q$ ) in the curbed channel to the spread of water on the shoulder, parking lane or traveled way section. This Section discusses uniform cross slope roadways and composite gutter sections. Composite gutter sections have a greater hydraulic capacity and are therefore preferred. [Figure 12.8-A](#) presents schematics of typical gutter sections. [Section 12.8.4](#) provides an example problem for the composite gutter commonly used by SDDOT. The uniform gutter computations are provided in [Section 12.8.3](#). If one of the alternative sections illustrated in [Figure 12.8-A](#) are proposed, see [HEC 22 \(Reference \(1\)\)](#) for procedures for calculating spread.

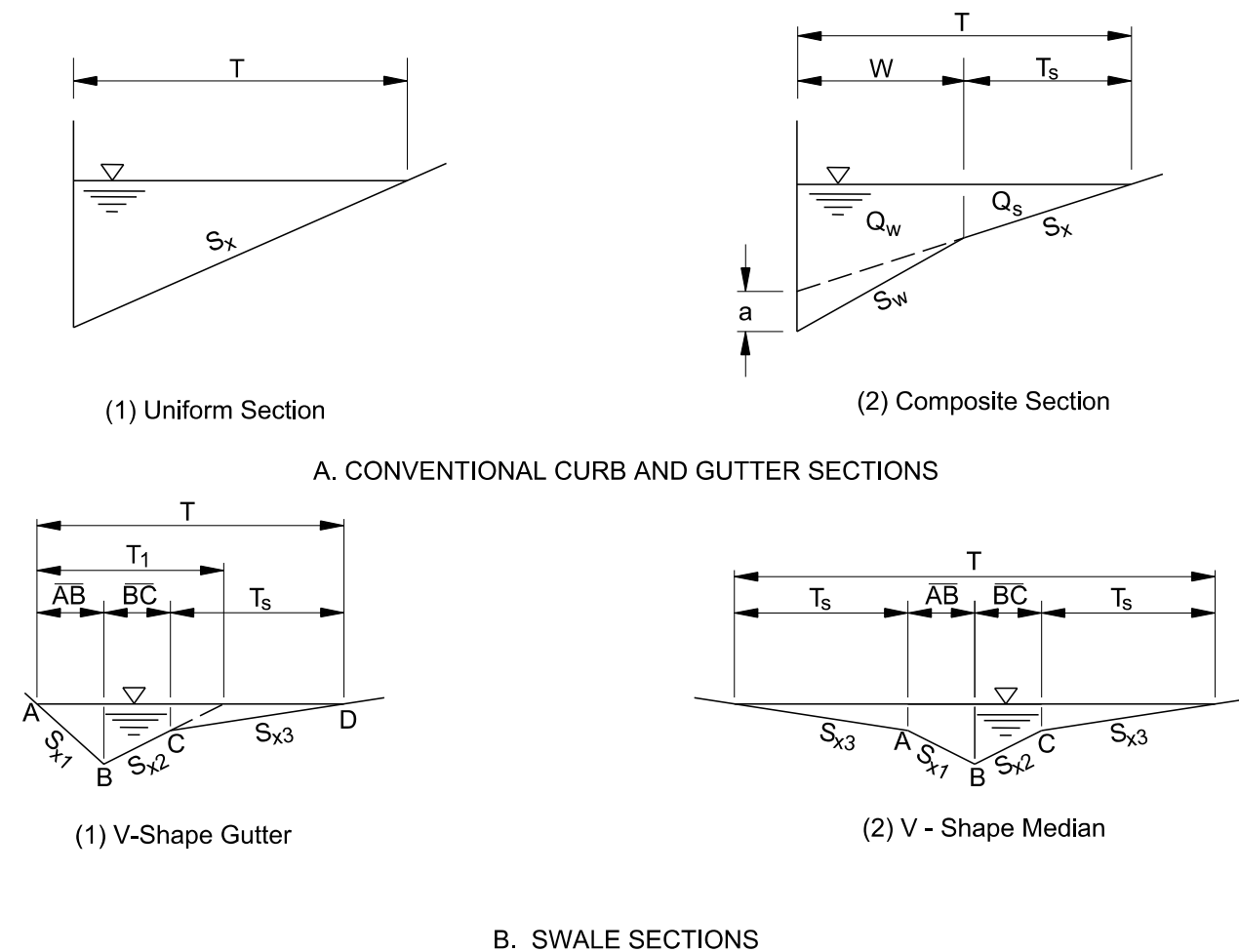

**Figure 12.8-A — TYPICAL CURB AND GUTTER SECTIONS**

**12.8.2 Capacity Relationship**

A modification of Manning’s equation can be used for computing flow in triangular channels:

$$Q = \frac{K_u}{n} S_x^{1.67} S_L^{0.5} T^{2.67} \tag{Equation 12.1}$$

or in terms of T:

$$T = \left( \frac{Qn}{K_u S_x^{1.67} S_L^{0.5}} \right)^{0.375} \tag{Equation 12.2}$$

where:

- Q = flow rate, cfs
- K<sub>u</sub> = 0.56
- n = Manning’s coefficient (see Figure 12.8-B)
- S<sub>x</sub> = cross slope, ft/ft
- S<sub>L</sub> = longitudinal slope, ft/ft
- T = width of flow (spread), ft

Type of Gutter or Pavement	Manning’s n
Concrete Gutter, troweled finish	0.012
Asphalt Pavement: Smooth texture	0.013
Rough texture	0.016
Concrete Gutter, Asphalt Pavement Smooth	0.013
Rough	0.015
Concrete Pavement Float finish	0.014
Broom finish	0.016

*Note: For gutters with small longitudinal slope, where sediment may accumulate, increase above n values by 0.02.*

*Note: The n value is 0.015 for SDDOT typical gutter with pavement. This is based on SDDOT typical pavements being rough texture asphalt or broom finished concrete with troweled finish concrete gutter.*

**Figure 12.8-B — MANNING’S n FOR GUTTERS**  
(after HDS 3, Table 1 ([Reference \(5\)](#)))

### 12.8.3 Uniform Cross Slope Procedure

[Example 12.8-1](#) illustrates the analysis of roadways and gutters with uniform cross slope using the above equations. The equations can also be solved using FHWA Hydraulic Toolbox; see [Section 18.2.4](#).

#### Example 12.8-1

Given: Gutter section illustrated in [Figure 12.8-A](#) (sketch A(1))

$$\begin{aligned} S_L &= 0.01 \text{ ft/ft} \\ S_x &= 0.02 \text{ ft/ft} \\ n &= 0.016 \end{aligned}$$

Find: (1) Spread at a flow of 1.8 cfs  
(2) Gutter flow at a spread of 8.0 ft

Solution (1):

*Step 1* Compute spread, T, using Equation 12.2:

$$\begin{aligned} T &= \left[ (Qn) / (K_u S_x^{1.67} S_L^{0.5}) \right]^{0.375} \\ T &= \left[ (1.8)(0.016) / \left\{ (0.56)(0.02)^{1.67} (0.01)^{0.5} \right\} \right]^{0.375} \\ T &= 9.0 \text{ ft} \end{aligned}$$

Solution (2):

*Step 1* Using Equation 12.1 with T = 8.0 ft and the information given above, determine Qn:

$$\begin{aligned} Qn &= K_u S_x^{1.67} S_L^{0.5} T^{2.67} \\ Qn &= (0.56)(0.02)^{1.67} (0.01)^{0.5} (8.0)^{2.67} \\ Qn &= 0.021 \text{ cfs} \end{aligned}$$

*Step 2* Compute Q from Qn determined in Step 1:

$$\begin{aligned} Q &= Qn / n \\ Q &= 0.021 / 0.016 \\ Q &= 1.3 \text{ cfs} \end{aligned}$$

### 12.8.4 Composite Gutter Section Procedure

The design of a composite gutter section requires the consideration of flow in the depressed segment of the gutter,  $Q_w$ . The equations provided below can be used to determine the flow in a width of gutter in a composite cross section,  $W$ , less than the total spread,  $T$ . The procedure for analyzing composite gutter sections is demonstrated in [Example 12.8-2](#).

$$E_o = 1 / \left\{ 1 + \frac{S_w / S_x}{\left[ 1 + \frac{S_w / S_x}{\frac{T}{W} - 1} \right]^{2.67}} - 1 \right\} \quad (\text{Equation 12.3})$$

$$Q_w = Q - Q_s \quad (\text{Equation 12.4})$$

$$Q = \frac{Q_s}{(1 - E_o)} \quad (\text{Equation 12.5})$$

where:

$Q_w$  = flow rate in the depressed section of the gutter, cfs

$Q$  = gutter flow rate, cfs

$Q_s$  = flow capacity of the gutter section above the depressed section, cfs

$E_o$  = ratio of flow in a chosen width (usually the width of a grate) to total gutter flow ( $Q_w/Q$ )

$S_w$  =  $S_x + a/W$ , ft/ft (see [Figure 12.8-A](#), sketch (A(2)))

#### Example 12.8-2

Given: SDDOT Type B Curb and Gutter  
Gutter section illustrated in [Figure 12.8-A](#) (sketch A(2))

(Note: The 2-in sloping section at the curb is not included).

$$\begin{aligned}
 S_L &= 0.01 \text{ ft/ft} \\
 S_x &= 0.02 \text{ ft/ft} \\
 S_w &= 0.05 \text{ ft/ft} \\
 W &= 2 \text{ ft} \\
 n &= 0.016
 \end{aligned}$$

- Find:
- (1) Gutter flow at a spread (T) = 8.0 ft
  - (2) Spread (T) at a gutter flow (Q) = 2 cfs

Solution (1):

- Step 1** Using the cross slope of the depressed gutter ( $S_w = 0.05$ ), compute “a” and the width of spread from the junction of the gutter and the road to the limit of the spread,  $T_s$ :

$$\begin{aligned}
 S_w &= 0.05 = a/W + S_x = a/2 + 0.02 \quad (a = 0.72 \text{ in}) \\
 T_s &= T - W = 8.0 - 2.0 \\
 T_s &= 6.0 \text{ ft}
 \end{aligned}$$

- Step 2** From Equation 12.1 (using  $T_s$ ):

$$\begin{aligned}
 Q_s n &= K_u S_x^{1.67} S_L^{0.5} T_s^{2.67} \\
 Q_s n &= (0.56) (0.02)^{1.67} (0.01)^{0.5} (6.0)^{2.67} \\
 Q_s n &= 0.0097 \text{ cfs} \\
 Q_s &= (Q_s n)/n = 0.0097/0.016 \\
 Q_s &= 0.61 \text{ cfs}
 \end{aligned}$$

- Step 3** Determine the gutter flow, Q, using Equations 12.3 and 12.5:

$$\begin{aligned}
 T/W &= 8.0/2 = 4.0 \\
 S_w/S_x &= 0.05/0.02 = 2.5 \\
 E_o &= 1 / \{1 + [(S_w/S_x) / ((1 + (S_w/S_x) / (T/W - 1))^{2.67} - 1)]\} \\
 E_o &= 1 / \{1 + [2.5 / ((1 + (2.5) / (4.0 - 1))^{2.67} - 1)]\} \\
 E_o &= 0.618 \\
 Q &= Q_s / (1 - E_o) \\
 Q &= 0.61 / (1 - 0.618) \\
 Q &= 1.6 \text{ cfs}
 \end{aligned}$$

Solution (2):

Because the spread cannot be determined by a direct solution, an iterative approach should be used. This approach is provided in [HEC 22 \(Reference 1\)](#), Section 4.3.2.2. If the FHWA Hydraulic Toolbox (Version 1.0) is used to determine the spread for a given discharge, the results are:

$$Q = 2.0 \text{ cfs}$$

$$T = 8.8 \text{ ft}$$

$$E_o = 0.573$$

$$\text{Area of flow} = 0.834 \text{ sq ft}$$

$$\text{Depth at curb} = 2.83 \text{ in with } a = 0.72 \text{ in}$$

The distribution of the flow is:

$$Q_w = E_o (Q) = 0.573 (2.0) = 1.15 \text{ cfs}$$

$$Q_s = Q - Q_w = 2.0 - 1.15 = 0.85 \text{ cfs}$$

$$T_s = T - W = 8.8 - 2 = 6.8 \text{ ft}$$

## 12.9 INLETS

### 12.9.1 General

Inlets are drainage structures used to collect surface water through a grate, a curb opening or a combination of both (see inlet types figure) and convey it to storm drains or to culverts. This Section discusses the various types of inlets used by SDDOT and recommends guidelines on the use of each type.

Drainage inlets are sized and located to limit the spread of water on the roadway to allowable widths for the design storm as specified in [Section 12.7.3](#). Grate inlets and the depression of curb opening inlets should be located outside the through traffic lanes to minimize the shifting of vehicles attempting to avoid them. All grate inlets should be bicycle safe (like the Type B grate) where used on roadways that allow bicycle travel.

### 12.9.2 Types

Inlets used for the drainage of highway pavements can be divided into four major classes. See the [SDDOT Standard Plates](#) for those grates used by the Department.

#### 12.9.2.1 Grate Inlets

These inlets consist of an opening in the gutter covered by one or more grates. They are best suited for use on continuous grades. Grate inlets have more capacity on steeper grades when compared to curb opening inlets. Because they are susceptible to clogging with debris, the use of standard grate inlets at sag points should be limited to minor sag point locations without debris potential. Special-design (oversize) grate inlets can be used at major sag points if sufficient capacity is provided for clogging. Otherwise, flanking inlets are needed.

SDDOT uses the following grate inlets:

1. Type A Frame and Grate. This is typically used on bridge approach slabs.
2. Type C Frame and Grate. This is typically used as a yard drain behind the curb and gutter.
3. Type E Frame and Grate. This is typically used with a valley-type gutter.

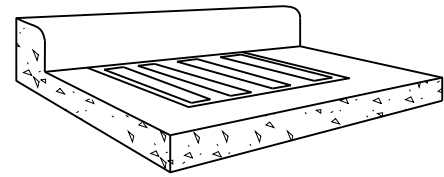

Grate Inlet

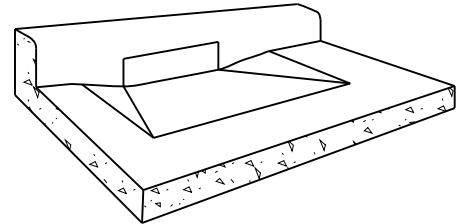

Curb-Opening Inlet

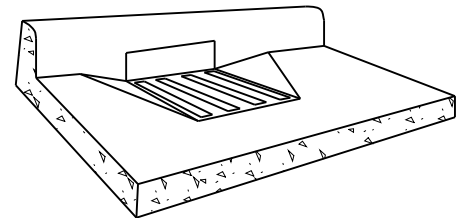

Combination Inlet

### Inlet Types



4. Types L, M and N Median Drains. These are used in depressed medians and roadside ditches.

### **12.9.2.2 Curb-Opening Inlets**

These inlets provide openings in the curb covered by a top slab. Curb-opening inlets are preferred at sag points because they can convey large quantities of water and debris. They may also be a viable alternative to grates in many locations where grates may be hazardous for pedestrians or bicyclists. They are generally not the first choice for use on continuous grades because of their poor hydraulic capacity. However curb opening inlets have more capacity on flatter grades when compared to grate inlets.

The SDDOT curb-opening inlet is designated as a Type S Reinforced Concrete Drop Inlet. SDDOT typical practice is to use the Type S inlet at sag locations.

### **12.9.2.3 Combination Inlets**

Various types of combination inlets are in use. Curb-opening and grate combinations are common, some with the curb opening upstream of the grate and some with the curb opening adjacent to the grate. The gutter grade, cross slope and proximity of the inlets to each other are significant factors when selecting this type of inlet. Combination inlets may be desirable in sags because they can provide additional capacity in the event of plugging.

The SDDOT Type B Frame and Grate is the Department's combination curb-opening and grate inlet. The grate uses 45° tilted bars sloped in the direction of flow to increase hydraulic capacity. The Type B is the most commonly used inlet by SDDOT, especially on continuous grades.

### **12.9.2.4 Slotted Drain Inlets**

These inlets consist of a slotted opening with bars perpendicular to the opening. Slotted inlets function as weirs because the flow usually enters perpendicular to the slot. They can be used to intercept sheet flow, collect gutter flow with or without curbs, modify existing systems to accommodate roadway widening or increased runoff, and reduce ponding depth and spread at grate inlets.

The *SDDOT Standard Plates* do not include any slotted drains; they are designed on a case-by-case basis. Slotted corrugated metal pipes may be used in median crossovers and, at times, in curb and gutter sections where large volumes of water need to be picked up. Slotted reinforced concrete pipe may be used as a median drain. [HEC 22 \(Reference \(1\)\)](#) contains design guidance.

### 12.9.3 Drop Inlets

A drop inlet provides a base for the drainage grate. Basically, the drop inlet represents the below-pavement structure (or basin) to collect the storm drainage from the inlets and to convey the drainage to the underground piping system.

Drop inlets also act as manholes by providing access to the underground piping system for maintenance and inspection. Drop inlets should be designed to follow the same location and spacing requirements as manholes in Section 12.11, in addition to the inlet location, spacing and capacity requirements in Section 12.10.

Precast drop inlet collars should be provided on drop inlets where the grate is placed within or adjacent to paved surfaces, including PCC pavement and asphalt concrete pavement. The collar allows movement of the pavement without affecting the drop inlet structure. SDDOT has developed standard precast drop inlet collars.

SDDOT has also developed drop inlet covers where inlets and access to the piping system are not needed. Use of these may be rare as it is desirable to provide access to the piping system.

Sumps in drop inlets may be provided when requested by the City and where the City is responsible for maintenance of the storm drainage system. The sumps are created by constructing the drop inlet floor 1 ft below the pipe flowline elevation. Sumps are provided to collect debris.

## 12.10 INLET LOCATION, SPACING AND CAPACITY

### 12.10.1 General

#### 12.10.1.1 Location

There are a number of locations where inlets may be necessary without regard to contributing drainage area. These locations should be marked on the plans prior to any hydraulic computations regarding discharge, water spread, inlet capacity or bypass. Examples of such locations are:

- Inlets should be placed on the upstream side of bridge approaches.
- Inlets should be placed at all low points in the gutter grade.
- Inlets should be placed upstream of intersecting streets.
- Inlets should be placed on the upstream side of a driveway entrance, curb-cut ramp or pedestrian crosswalk even if the hydraulic analysis places the inlet further down grade or within the feature.
- Inlets should be placed upstream of median breaks.
- Inlets should be placed to capture flow from intersecting streets before it reaches the major highway.
- Flanking inlets in sag vertical curves are standard practice. See [Section 12.10.8](#).
- Inlets should be placed to prevent water from sheeting across the highway (i.e., place the inlet before the superelevation transition begins).
- Inlets should not be located in the path where pedestrians walk.
- Inlets connected by pips should have a maximum spacing according to the manhole spacing requirements in [Section 12.11.2](#) to limit pipe lengths for maintenance purposes.

#### 12.10.1.2 Spacing Process

Locate inlets from the crest and work downgrade to the sag points. The location of the first inlet from the crest can be found by determining the length of pavement and the area in back of the curb sloping toward the roadway that will generate the design runoff. The design runoff can be computed as the maximum allowable flow in the curbed channel that will meet the design frequency and allowable water spread. Where the contributing drainage area consists of a strip of land parallel to and including a portion of the highway, the location of the first inlet can be calculated as follows:

$$L = \frac{43,560 Q_t}{CiW} \quad (\text{Equation 12.6})$$

where:

- L = distance from the crest, ft
- $Q_t$  = maximum allowable flow, cfs
- C = composite runoff coefficient for contributing drainage area
- W = width of contributing drainage area, ft
- i = rainfall intensity for design frequency, in/hour

Equation 12.6 is an alternate form of the Rational Equation. If the drainage area contributing to the first inlet from the crest is irregular in shape, trial and error may be necessary to match a design flow with the maximum allowable flow.

To space successive downgrade inlets, it is necessary to compute the amount of flow that will be intercepted by the inlet ( $Q_i$ ) and subtract it from the total gutter flow to compute the bypass. The bypass from the first inlet is added to the computed flow to the second inlet, the total of which must be less than the maximum allowable flow dictated by the allowable water spread. [Figure 12.10-E](#) (see [Section 12.10.9](#)) is an inlet spacing computation sheet that can be used to record the spacing calculations. However, inlet calculations are usually accomplished with software.

FHWA has investigated the inlet interception capacity of all types of grate inlets, slotted drain inlets, curb-opening inlets and combination inlets. HEC 22 ([Reference \(1\)](#)) or the FHWA Hydraulic Toolbox (see [Section 18.2.4](#)) may be used to analyze the flow in gutters and the interception capacity of all types of inlets on continuous grades and sags. Both uniform and composite cross slopes can be analyzed.

### 12.10.2 Grate Inlets on Grade

The capacity of a grate inlet depends upon its geometry, cross slope, longitudinal slope, total gutter flow, depth of flow and pavement roughness. The depth of water next to the curb is the major factor in the interception capacity of both gutter inlets and curb-opening inlets. At low velocities, all of the water flowing in the section of gutter occupied by the grate (frontal flow), is intercepted by grate inlets and a small portion of the flow along the length of the grate (side flow) is intercepted. On steep longitudinal slopes, a portion of the frontal flow may tend to splash over the end of the grate for some grates.

The ratio of frontal flow to total gutter flow,  $E_o$ , for a straight cross slope is given by the following equation:

$$E_o = Q_w / Q = 1 - (1 - W / T)^{2.67} \quad (\text{Equation 12.7})$$

where:

- $Q$  = total gutter flow, cfs  
 $Q_w$  = flow in width  $W$ , cfs  
 $W$  = width of depressed gutter or grate, ft  
 $T$  = total spread of water in the gutter, ft

The ratio of side flow,  $Q_s$ , to total gutter flow is:

$$Q_s/Q = 1 - Q_w/Q = 1 - E_o \quad (\text{Equation 12.8})$$

The ratio of frontal flow intercepted to total frontal flow,  $R_f$ , is expressed by the following equation:

$$R_f = 1 - 0.09 (V - V_o) \quad (\text{Equation 12.9})$$

where:

- $V$  = velocity of flow in the gutter, fps  
 $V_o$  = gutter velocity where splash-over first occurs, fps

This ratio is equivalent to frontal-flow interception efficiency. [Figure 12.10-A](#) (from HEC 22, Chart 5) provides a solution of Equation 12.9 that incorporates grate length, bar configuration and gutter velocity at which splash-over occurs. The gutter velocity needed to use [Figure 12.10-A](#) is total gutter flow divided by the area of flow. [Figure 12.10-A](#) shows that parallel bar grates are the most efficient grates on steep slopes but are not bicycle safe. The grates tested in a FHWA research study are described in HEC 22 ([Reference \(1\)](#)).

The equations provided in [Figure 12.10-B](#) can be used to determine splash-over velocities ( $V_o$ ) for various grate configurations. Equation 12.10 can then be used to compute the portion of frontal flow intercepted by the grate.

The ratio of side flow intercepted to total side flow,  $R_s$ , or side-flow interception efficiency, is expressed by:

$$R_s = 1 / [1 + (0.15V^{1.8}/S_x L^{2.3})] \quad (\text{Equation 12.10})$$

where:

- $V$  = velocity of flow in gutter, fps  
 $L$  = length of the grate, ft  
 $S_x$  = cross slope, ft/ft

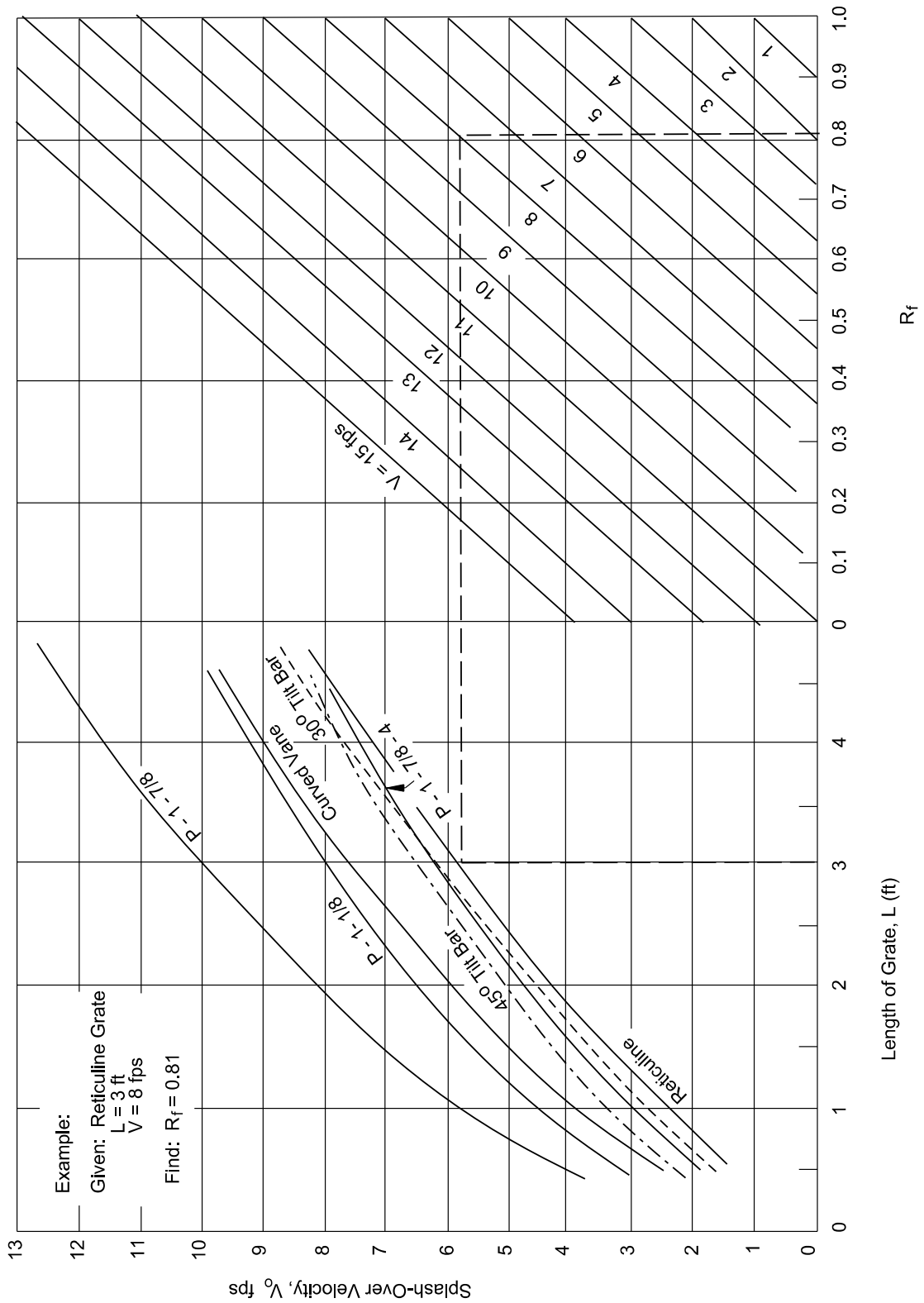

**Figure 12.10-A — GRATE INLET FRONTAL-FLOW INTERCEPTION EFFICIENCY**  
 (Reference (1))

Grate Configuration	Typical Bar Spacing (in)	Splash-over Velocity Equation
Parallel Bars (P-1 $\frac{7}{8}$ )	2.0	$V_o = 2.218 + 4.031L - 0.649L^2 + 0.056L^3$
Parallel Bars (P-1 $\frac{1}{8}$ )	1.2	$V_o = 1.762 + 3.117L - 0.451L^2 + 0.033L^3$
Curved Vane	4.5	$V_o = 1.381 + 2.78L - 0.300L^2 + 0.020L^3$
45° Tilt Bar	4.0	$V_o = 0.988 + 2.625L - 0.359L^2 + 0.029L^3$
Parallel Bars with Transverse Rods (P-1 $\frac{7}{8}$ -4)	2.0 Parallel/ 4.0 Transverse	$V_o = 0.735 + 2.437L - 0.265L^2 + 0.018L^3$
30° Tilt Bar	4.0	$V_o = 0.505 + 2.344L - 0.200L^2 + 0.014L^3$
Reticuline	N/A	$V_o = 0.030 + 2.278L - 0.179L^2 + 0.010L^3$

**Figure 12.10-B — SPASH-OVER VELOCITY EQUATIONS**

The efficiency,  $E$ , of a grate is expressed as:

$$E = R_f E_o + R_s(1 - E_o) \quad (\text{Equation 12.11})$$

The interception capacity of a grate inlet on grade is equal to the efficiency of the grate multiplied by the total gutter flow:

$$Q_i = EQ = Q[R_f E_o + R_s(1 - E_o)] \quad (\text{Equation 12.12})$$

### **Example 12.10-1**

Given: Given the gutter section from [Example 12.8-2](#):

$$\begin{aligned} T &= 8.0 \text{ ft} & S_L &= 0.01 \text{ ft/ft} \\ W &= 2.0 \text{ ft} & S_x &= 0.02 \text{ ft/ft} \\ n &= 0.016 & S_w &= 0.05 \text{ ft/ft (continuous gutter depression, } a = 0.72 \text{ in)} \end{aligned}$$

Find: The interception capacity of a SDDOT Type B Frame and Grate. The grate has outside dimensions of 17.75 in (1.5 ft) by 35.5 in (3 ft) and has 11 tilted bars. The titled bars are 2-in high and at a 45-degree angle to vertical. (Note: Although this is a combination inlet, the grate provides all of the capacity and the curb opening provides for debris).

Solution: From [Example 12.8-2](#):

$$E_o = 0.618$$

$$Q = 1.6 \text{ cfs}$$

**Step 1** Compute the average gutter velocity:

$$V = Q/A = 1.6/A$$

$$A = 0.5T^2S_x + 0.5aW$$

$$A = 0.5(8.0)^2(0.02) + 0.5(0.06)(2.0) = 0.64 + 0.06$$

$$A = 0.70 \text{ sq ft}$$

$$V = 1.6/0.70 = 2.29 \text{ fps}$$

**Step 2** Determine the frontal flow efficiency using [Figure 12.10-A](#):

$$R_f = 1.0$$

**Step 3** Determine the side flow efficiency using [Equation 12.10](#):

$$R_s = 1/[1 + (0.15 V^{1.8}) / (S_x L^{2.3})]$$

$$R_s = 1/[1 + (0.15) (2.29)^{1.8} / [(0.02) (3.0)^{2.3}]$$

$$R_s = 0.27$$

**Step 4** Compute the interception capacity using [Equation 12.12](#). (Because the Type B grate is only 18-in wide, replace  $E_o$  with  $E_o = E_o(A'_w / A_w)$  where  $A_w$  is the area of flow over the 2-ft gutter and  $A'_w$  is the area of flow over the grate):

$$E'_o = E_o(A'_w / A_w) = 0.618(0.27/0.34) = 0.491$$

$$Q_i = Q[R_f E_o + R_s (1 - E_o)]$$

$$= (1.6)[(1.0)(0.491) + (0.27)(1 - 0.491)] = 1.6 (0.491 + 0.137)$$

$$= 1.6(0.628) = 1.00 \text{ cfs}$$

$$E = Q_i/Q = 1.00/1.6 = 0.625 \text{ or } 63\%$$

The calculations show that the Type B inlet is 63% efficient and captures 1.0 cfs while 0.60 cfs is bypassed. The FHWA Hydraulic Toolbox (Version 1.0) gives similar results.

### 12.10.3 Grate Inlets In Sag

Although curb-opening inlets are generally preferred to grate inlets at a sag, grate inlets can be used successfully. For minor sag points where debris potential is limited, grate inlets without a curb-opening inlet can be utilized. An example of a minor sag point might be on a ramp as it joins a mainline. Curb-opening inlets in addition to a grate are preferred at sag points where debris is likely, such as on a city street (see [Section 12.10.7](#)). For major sag points, such as on divided high-speed highways, a curb-opening inlet is preferable to a grate inlet because of its hydraulic capacity and debris-



handling capabilities. When grates are used, it is good practice to assume that half the grate is clogged with debris.

Where significant ponding can occur, in locations such as underpasses and in sag vertical curves in depressed sections, it is good engineering practice to place a minimum of one flanking inlet on each side of the sag point inlet. The flanking inlets should be placed so that they will limit spread on low-gradient approaches to the low point and act in relief of the inlet at the low point if it should become clogged or if the allowable spread is exceeded. [Section 12.10.8](#) presents a further discussion and methodology.

A grate inlet in a sag operates as a weir up to depths dependent on the size of the grate and as an orifice at greater depths. Grates of larger dimension will operate as weirs to greater depths than smaller grates.

The capacity of a grate inlet operating as a weir is:

$$Q_i = C_w P d^{1.5} \quad (\text{Equation 12.13})$$

where:

- P = perimeter of grate excluding bar widths and side against curb, ft
- $C_w$  = 3.0, weir coefficient
- d = average depth across the grate ( $0.5(d_1 + d_2)$ ), ft (see sketch below)

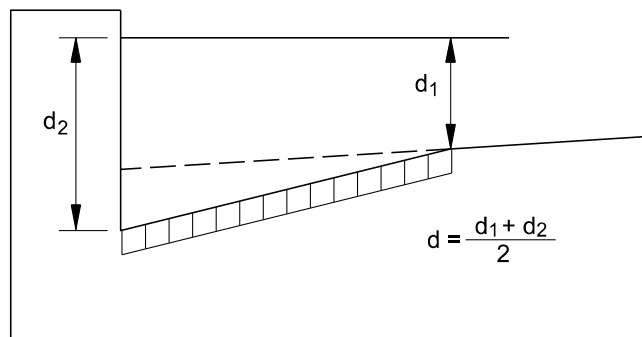

The capacity of a grate inlet operating as an orifice is:

$$Q_i = C_o A_g (2gd)^{0.5} \quad (\text{Equation 12.14})$$

where:

- $C_o$  = 0.67, orifice coefficient
- $A_g$  = clear opening area of the grate, sq ft
- g = 32.2 ft/sec<sup>2</sup>

The use of Equation 12.14 requires the clear area of opening of the grate, which is obtained by multiplying the total area by the opening ratios given in the following table (from HEC 22 ([Reference \(1\)](#)):

<u>Grate</u>	<u>Opening Ratio</u>	<u>SDDOT Inlet</u>
P-1 $\frac{7}{8}$ -4	0.8	
P-1 $\frac{7}{8}$	0.9	
P-1 $\frac{1}{8}$	0.6	
Reticuline	0.8	Types C, D, E, L & M
Curved vane	0.35	
Tilt-bar	0.34	Type B

### **Example 12.10-2**

Given: Given the gutter section from Example 12.8-2:

$$\begin{aligned}
 T &= 8.0 \text{ ft} & S_L &= 0.010 \text{ ft/ft} \\
 & & S_x &= 0.02 \text{ ft/ft} \\
 n &= 0.016 & S_w &= 0.05 \text{ ft/ft (continuous gutter depression, } a = 0.72 \text{ in)}
 \end{aligned}$$

Find: The capacity of a SDDOT Type B Frame and Grate in a sump. The grate has outside dimensions of 17.75 in (1.5 ft) by 35.5 in (3 ft) and has 11 tilted bars. The tilted bars are 2-in high and at a 45-degree angle to vertical. (Note: Although this is a combination inlet, only the grate capacity will be assessed).

Solution: From [Example 12.8-2](#):

$$\begin{aligned}
 E_o &= 0.618 \\
 Q &= 1.6 \text{ cfs}
 \end{aligned}$$

Solution:

**Step 1** Determine the required grate perimeter:

Depth at curb,  $d_2$ :

$$\begin{aligned}
 d_2 &= TS_x + a = (8)(0.02) + 0.72/12 = 0.16 + 0.06 \\
 d_2 &= 0.22 \text{ ft}
 \end{aligned}$$

Average depth over grate:

$$\begin{aligned}
 d &= d_2 - ((\text{grate width})/2)S_w \\
 d &= 0.22 - (1.5/2)(0.05) \\
 d &= 0.18 \text{ ft with no clogging}
 \end{aligned}$$

$d = 0.20$  ft with 50% clogging (assume that the upper half is clogged so that only 25% of the 1.5-ft width is subtracted to determine average depth)

From Equation 12.13:

$$P = Q_i / [C_w d^{1.5}]$$

$$P = (1.6) / [(3.0)(0.20)^{1.5}]$$

$$P = 5.96 \text{ ft (use 6 ft)}$$

Assuming 50% clogging along the grate length (i.e., width is reduced by 50%):

$$P_{\text{effective}} = 6.0 = (0.5)(2)W + L$$

if  $W = 1.5$  ft, then  $L = 4.5$  ft

The Type B Grate is a 1.5 ft by 3 ft grate:

$$P_{\text{effective}} = (0.5)(1.5)(2.0) + (3)$$

$$P_{\text{effective}} = 4.5 \text{ ft (one grate)}$$

$$P_{\text{effective}} = 7.5 \text{ ft (2 grates)} > 6 \text{ ft needed, OK}$$

**Step 2** Check depth of flow at curb using Equation 12.13 using two grates:

$$d = [Q / (C_w P)]^{0.67}$$

$$d = [1.6 / (3.0)(7.5)]^{0.67}$$

$$d = 0.17 \text{ ft or 2 in}$$

Therefore, OK.

**Step 3** Check depth of flow assuming orifice flow, Equation 12.14:

$$A_g = 0.75(3)(0.34) = 0.765 \text{ sq ft (clogged area is further reduced by opening ratio)}$$

$$Q_i = C_o A_g (2gd)^{0.5} = 0.67(0.765)(64.4d)^{0.5} = 1.6 \text{ cfs}$$

$$d = 0.15 \text{ ft (1 grate)}$$

$$d = 0.04 \text{ ft (2 grates)}$$

Because these depths are lower than those in Step 2, orifice flow does not occur.

#### 12.10.4 Curb Opening Inlets on Grade

Curb-opening inlets are effective in the drainage of highway pavements where flow depth at the curb is sufficient for the inlet to perform efficiently. Curb openings are relatively free of clogging tendencies and offer little interference to traffic operation. They are a viable alternative to grates in many locations where grates would be in traffic lanes or would be hazardous for pedestrians or bicyclists.

The length of a curb-opening inlet required for total interception of gutter flow on a pavement section with a straight cross slope is expressed by:

$$L_T = KQ^{0.42} (S_L)^{0.3} (1/(nS_x))^{0.6} \quad (\text{Equation 12.15})$$

where:

$$K = 0.6$$

$L_T$  = curb-opening length required to intercept 100% of the gutter flow, ft

The efficiency of curb-opening inlets shorter than the length required for total interception is expressed by:

$$E = 1 - (1 - L/L_T)^{1.8} \quad (\text{Equation 12.16})$$

where:

$L$  = curb-opening length, ft

The length of inlet required for total interception by depressed curb-opening inlets or curb openings in depressed gutter sections or for a continuously depressed gutter (composite gutter) can be found by the use of an equivalent cross slope,  $S_e$ , in Equation 12.17:

$$S_e = S_x + S'_w E_o \quad (\text{Equation 12.17})$$

where:

$S'_w = (a/12W) = S_w - S_x$  = cross slope of the gutter measured from the cross slope of the pavement, ft/ft

$a$  = gutter depression, in

$E_o$  = ratio of flow in the depressed section to total gutter flow. It is determined by the gutter configuration upstream of the inlet (see [Section 12.8.4](#)).

Note:  $S_e$  can be used to calculate the length of curb opening by substituting  $S_e$  for  $S_x$  in Equation 12.15.

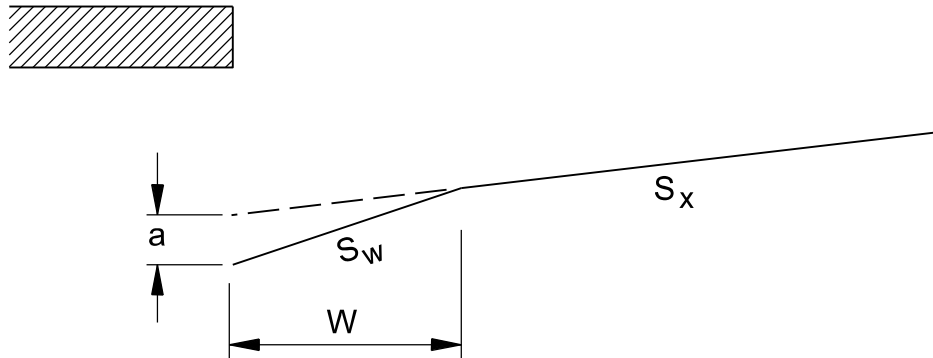

### **Example 12.10-3**

Given: The gutter section from [Example 12.8-2](#):

$$\begin{array}{ll} T = 8.0 \text{ ft} & S_L = 0.010 \text{ ft/ft} \\ W = 2.0 \text{ ft} & S_x = 0.02 \text{ ft/ft} \\ n = 0.016 & S_w = 0.05 \text{ ft/ft} \end{array}$$

Find: The interception capacity of a SDDOT Type S curb opening inlet that is 10-ft long. Use  $a = 4.2$  in for Type S; see [Section 12.10.5](#).

Solution: From [Example 12.8-2](#):

$$\begin{array}{l} S_w = 0.05 \text{ ft/ft} \\ E_o = 0.618 \\ Q = 1.6 \text{ cfs} \end{array}$$

The FHWA Hydraulic Tool box (Version 1.0) indicates that a 10-ft curb opening inlet with a local depression of 4.2 in captures all of the 1.6 cfs. The results can be checked with the equations:

(Because local depression is added,  $S'_w$  is modified.)

$$\begin{array}{l} S'_w = a/12W = 4.2/12(2) = 0.18 \\ S_e = S_x + S'_w E_o = 0.02 + 0.18(0.618) = 0.13 \end{array}$$

Using Equation 12.15:

$$L_T = (0.6)(1.6)^{0.42}(0.01)^{0.3}(1/((0.016)(0.13)))^{0.6}$$

$$L_T = (0.6)(1.22)(0.25)(40.66) = 7.44 \text{ ft}$$

Using Equation 12.16:

$$L/L_T = 10/7.44 > 1, \text{ use } 1 \text{ which gives } E = 1$$

$$Q_i = EQ = (1)(1.6) = 1.6 \text{ cfs}$$

### 12.10.5 Curb-Opening Inlets in Sag

The capacity of a curb-opening inlet in a sag depends on the water depth at the curb, the curb-opening length and the height of the curb opening. The inlet operates as a weir to depths equal to the curb-opening height and as an orifice at depths greater than 1.4 times the opening height. At depths between 1.0 and 1.4 times the opening height, flow is in a transition stage. See [Figure 12.10-C](#) for a definition sketch.

The equation for the interception capacity of a depressed curb-opening inlet operating as a weir is:

$$Q_i = C_W(L + 1.8W)d^{1.5} \quad \text{(Equation 12.18)}$$

where:

$C_W$  = 2.3 (with depression)

$L$  = length of curb opening, ft

$W$  = width of depression, ft

$d$  = depth of water at curb measured from the normal cross slope, ft (i.e.,  $d = TS_x$  for a uniform gutter and  $d = a + TS_x$  for a composite section)

The weir equation is applicable to depths at the curb less than or equal to the height of the opening plus the depth of the depression ( $D \leq h + a$ ).

The weir equation for curb-opening inlets without a depression becomes:

$$Q_i = C_W L d^{1.5} \quad \text{(Equation 12.19)}$$

$C_W$  = 3.0 (without depression)

The depth limitation for operation as a weir becomes  $d \leq h$ .

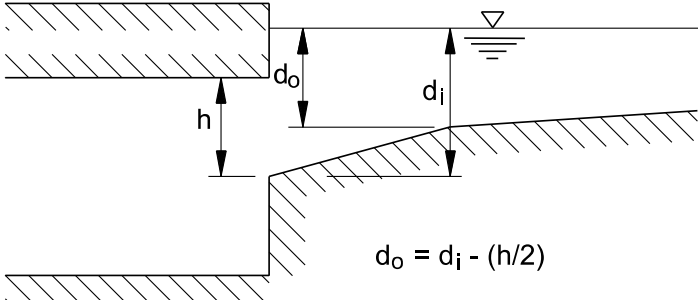

a. Horizontal Throat

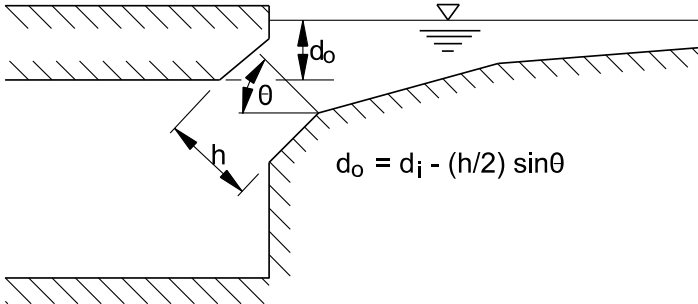

b. Inclined Throat

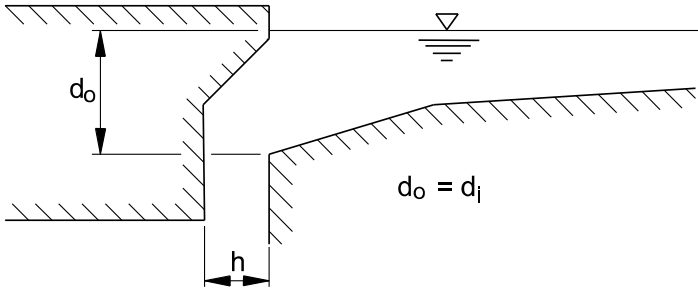

c. Vertical Throat

Figure 12.10-C — CURB OPENING INLETS

Curb-opening inlets operate as orifices at depths greater than approximately 1.4 times the height of curb opening (1.4h). The interception capacity can be computed by Equation 12.20. The depth at the inlet includes any gutter depression:

$$Q_i = C_o h L [2g(d_o)]^{0.5} \quad (\text{Equation 12.20})$$

where:

- $C_o$  = orifice coefficient (0.67)
- $d_o$  = effective head on the center of the orifice throat, ft (see [Figure 12.10-C](#))
- $h$  = height of curb-opening orifice, ft
- $L$  = length of orifice opening, ft
- $d_i$  = depth at lip of curb opening, ft =  $d + a/12 = TS_x + a/12$  ( $a$  = local depression)

The following applies to the local depression:

1. Weir Flow.  $a$  = local gutter depression, in. This depression is used to determine if the inlet is in weir flow only. Local depression is only used to check if the orifice is submerged.
2. Orifice Flow.  $a$  = local depression at curb opening, in. This depression is used in orifice flow inlet capacity computations.

The SDDOT Type S drop inlet has an inclined throat that has an angle  $\theta = \tan^{-1}(12/4) = 71.6$  degrees,  $h = 5.75$  in (0.48 ft), and local depression slope,  $S_w = 0.125$  ft/ft (1.5 in/ft) for the first 16 in and then 4 in/ft for the remainder. The following applies:

1. Weir Flow. Use Equation 12.18 with  $W = 2$  ft and  $d$  calculated with the Type B curb & gutter, which has  $S_w = 0.05$  ft/ft (0.75 in/ft).
2. Orifice Flow. Use Equation 12.20 with the following:

$$\begin{aligned} a &= 16 \text{ in } (1.5 \text{ in/ft})/12 + (8 \text{ in})(4 \text{ in/ft})/12 - 2 \text{ ft}(S_x)(12) \\ &= 4.67 - 24S_x \text{ inches, where } S_x \text{ is in ft/ft} \end{aligned}$$

$$a = 4.2 \text{ in for } S_x = 0.02 \text{ ft/ft}$$

$$d_i = d + a/12 = TS_x + (4.67 - 24S_x)/12 = TS_x - 2S_x + 0.39$$

$$d_i = S_x(T - 2) + 0.39$$

$$d_o = d_i - (h/2)\sin\theta = S_x(T - 2) + 0.39 - (0.48/2)0.949$$

$$d_o = S_x(T - 2) + 0.16$$



**Example 12.10-4**

Given: Type S curb opening inlet in a sump location with Type B curb & gutter for approach. Use [Example 12.8-2](#), Type B gutter flow ( $Q = 1.6$  cfs) for  $T = 8.0$  ft and  $a = 0.72$  in (local gutter depression), and:

$$\begin{aligned} L &= 10 \text{ ft} \\ h &= 0.48 \text{ ft} \\ a &= 4.2 \text{ in (local depression at curb opening)} \\ W &= 2 \text{ ft} \end{aligned}$$

Find:  $Q_i$

Solution:

**Step 1** Determine depth in gutter at curb,  $d$ :

$$\begin{aligned} d &= d + a \text{ (Use "a" for gutter depression)} \\ d &= TS_x + a \\ d &= (0.02)(8.0) + 0.72/12 \\ d &= 0.22 \text{ ft} \\ d &< (h + a) = 0.48 + 0.06 = 0.54 \text{ ft; therefore, weir flow controls} \end{aligned}$$

**Step 2** Use Equation 12.18 to find  $Q_i$ :

$$\begin{aligned} P &= L + 1.8 W \\ P &= 10 + (1.8)(2) \\ P &= 13.6 \text{ ft} \\ Q_i &= C_w (L + 1.8 W) d^{1.5} \\ Q_i &= (2.3) (13.6) (0.22)^{1.5} \\ Q_i &= 3.2 \text{ cfs} \end{aligned}$$

The FHWA Hydraulic Toolbox also indicates that the inlet is in weir flow and will accept all the flow. By trial and error, the flow must be 51.4 cfs for this inlet to operate in orifice flow. At this flow, the depth at the curb is 8.3 in.

**12.10.6 Combination Inlet on Grade**

The interception capacity of a combination inlet consisting of a curb opening and grate placed side-by-side is no greater than that of the grate alone. Capacity is computed by neglecting the curb opening. The Type B inlet is treated in this manner. A combination inlet is sometimes used with a part of the curb opening placed upstream of the grate. The curb opening in such an installation intercepts debris which might otherwise clog the grate and is called a "sweeper" inlet. A sweeper combination inlet has an interception capacity equal to the sum of the curb opening upstream of the grate plus

the grate capacity, except that the frontal flow and thus the interception capacity of the grate is reduced by interception by the curb opening.

### **12.10.7 Combination Inlet on Sag**

Combination inlets consisting of a grate and a curb opening are considered advisable for use in sags where hazardous ponding can occur. Equal length inlets refer to a grate inlet placed alongside a curb opening inlet, both of which have the same length. The interception capacity of the equal length combination inlet is essentially equal to that of a grate alone in weir flow. In orifice flow, the capacity of the equal length combination inlet is equal to the capacity of the grate plus the capacity of the curb opening. If two Type B grates are added to the 10-ft curb opening in [Example 12.10-3](#) and the inlet is treated as a sweeper inlet, the FHWA Hydraulic Toolbox shows that the combination will accommodate 44 cfs before going into orifice flow. This example is provided only to demonstrate the potential additional capacity that can be gained using inlets in combination. The Type B grate should not be used in a sump condition, because it is designed to be used on a grade. A better use of the two Type B grates is to use them upstream of the sump as flanking inlets (see [Section 12.10.8](#)).

### **12.10.8 Flanking Inlets**

At major sag points where significant ponding may occur, such as underpasses or sag vertical curves in depressed sections, it is recommended practice to place a minimum of one flanking inlet on each side of the inlet at the sag point. The flanking inlets can be located so that they will function before the water spread exceeds the allowable spread at the sump location. The flanking inlets should be located so that they will receive all of the flow when the primary inlet at the bottom of the sag is clogged. They should do this without exceeding the allowable spread at the bottom of the sag.

If the flanking inlets are the same dimension as the primary inlet, they will each intercept one-half the design flow when they are located so that the depth of ponding at the flanking inlets is 63% of the depth of ponding at the low point. See [Figure 12.10-D](#). If the flanking inlets are not the same size as the primary inlet, it will be necessary to either develop a new factor or perform a trial-and-error solution using assumed depths with the weir equation to determine the capacity of the flanking inlet at the given depths (see HEC 22 ([Reference \(1\)](#))). The AASHTO *Green Book* ([Reference \(4\)](#)) on geometrics specifies maximum K values for various design speeds and a maximum K of 167 considering drainage.

At sag points where a) water cannot obtain significant ponding depth, b) there are minimal overtopping effects, and c) a Type S drop inlet is used, then smaller flanking inlets (Type B) or none at all may be considered. This is because curb opening Type S drop inlets have less potential to clog than grate inlets.

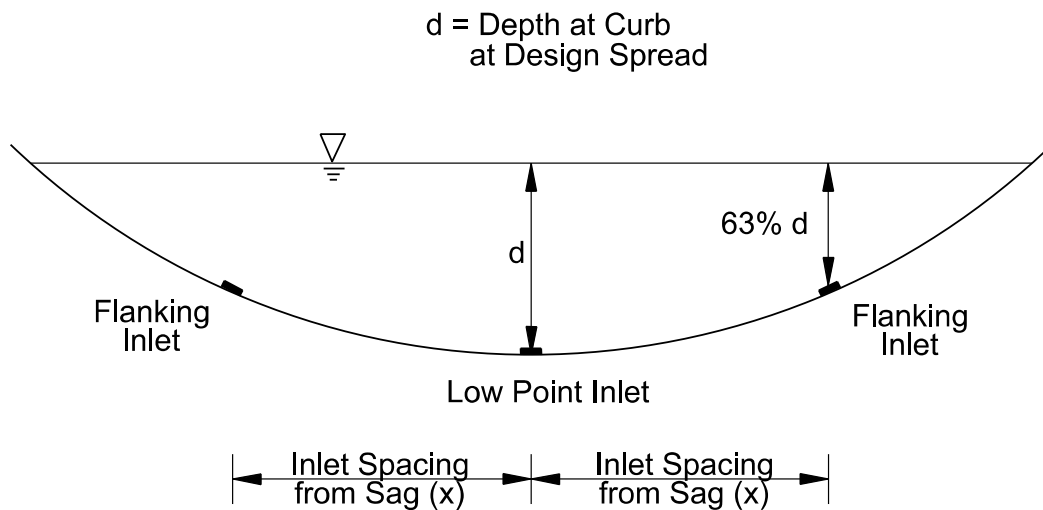

**Figure 12.10-D — FLANKING INLETS AT SAG POINT**

For a symmetrical sag vertical curve, the distance “X” to the flanking inlet is determined as follows:

$$X = (200d_1K)^{0.5} \quad \text{(Equation 12.21)}$$

where:

X = distance to flanking inlets from sag point, ft

K = rate of vertical curve, which is the length of curve per percent difference in grades,  $K = L/(G_2 - G_1)$

d = depth at curb at sag point at design spread, ft

$d_1$  = depth from bottom of sag to flanking inlet =  $(d - d_f)$ , ft

$d_f$  = depth over flanking inlets to carry all the design flow into both flanking inlets, ft

Where flanking inlets are the same size as the primary inlet,  $d_f = 0.63d$  and Equation 12.21 reduces to  $X = (74dK)^{0.5}$ .

### **Example 12.10-5**

Given: A 500-ft sag vertical curve at an underpass on a 4-lane divided highway with beginning and ending slopes of -2.5% and +2.5% respectively. The spread at design Q cannot exceed the shoulder width of 8 ft.

$$S_x = 0.02$$

Find: The location of the flanking inlets if located to function in relief of the Type S inlet at the low point when the inlet at the low point is clogged.

Solution:

**Step 1** Find the rate of vertical curvature, K:

$$K = L/(S_{\text{ending}} - S_{\text{beginning}})$$

$$K = 500 \text{ ft}/(2.5\% - (-2.5\%))$$

$$K = 100 \text{ ft}/\%$$

**Step 2** Determine depth in sump at design spread:

Using the FHWA Hydraulic Toolbox, Type S inlet in a sump will have  $T = 8$  ft for a  $Q$  of 4.2 cfs at  $d = 0.22$  ft.

**Step 3** Determine the depth for the flanking inlet locations:

Using the FHWA Hydraulic Toolbox (Version 1.0):

- Try Type B inlet with  $S = 0.025$ ,  $S_x = 0.02$ ,  $Q = 2.1$  cfs, which gives  $T = 7.4$  ft at a  $d = 2.5$  in (0.208 ft), but intercepted flow is only 1.5 cfs. A second Type B would have to be used downstream to capture the 0.6 cfs of bypass.
- Try Type B in sump with  $Q = 2.1$  cfs gives  $d = 0.24$  ft and  $T = 11.4$  ft which exceeds allowable spread; two Type B inlets also exceeds spread, but three Type B inlets gives  $T = 0.15$  ft and  $T = 7$  ft.
- Try Type S in sump with  $S = 0.025$ ,  $S_x = 0.02$ ,  $Q = 2.1$  cfs which gives  $d = 0.14$  ft and  $T = 3.9$  ft.

Use Type S inlets as flankers with  $d_f = 0.14$  ft. This depth matches the approximation of using  $d = 63\%$  of sag inlet  $= 0.63(0.22) = 0.14$  ft

**Step 4** Determine distance to flanking inlets:

$$d_1 = 0.22 - 0.14 = 0.08 \text{ ft}$$

$$X = (200d_1K)^{0.5} = \{(200)(0.08)(100)\}^{0.5} = 40.0 \text{ ft}$$

or

$$X = (74dK)^{0.5} = \{(74)(0.22)(100)\}^{0.5} = 40.3 \text{ ft}$$

Therefore, flanking inlet spacing = 40 ft from the low point in the sag.

### 12.10.9 Inlet Spacing Computations

To design the location of the inlets for a given project, information such as a layout or plan sheet suitable for outlining drainage areas, road profiles, typical cross sections, grading cross sections, superelevation diagrams and contour maps are necessary. The inlet computation sheet, [Figure 12.10-E](#), should be used to document the computations. A step-by-step procedure is as follows:

- |               |                            |  |
|---------------|----------------------------|--|
| <i>Step 1</i> |                            | Complete the blanks on top of the sheet to identify the job by project number, route, date and your initials.  |
| <i>Step 2</i> |                            | Mark on the plan the location of inlets that are necessary without consideration of any specific drainage area.  |
| <i>Step 3</i> |                            | Start at a high point, at one end of the project if possible, and work towards the low point. Then, begin at the next high point and work backwards toward the same low point.   |
| <i>Step 4</i> |                            | To begin the process, select a trial drainage area that is approximately 300 ft to 500 ft below the high point and outline the area on the plan. Include any area that may drain over the curb and onto the roadway. Use drainage area maps. Where practical, drainage from large areas behind the curb should be intercepted before it reaches the roadway or gutter. |
| <i>Step 5</i> | Col. 1<br>Col. 2<br>Col.19 | Describe the location of the proposed inlet by number and station in Columns 1 and 2. Identify the curb and gutter type in the Remarks, Column 19. A sketch of the cross section should be provided in the open area of the computation sheet.   |
| <i>Step 6</i> | Col. 3                     | Compute the drainage area in acres outlined in Step 4 and record in Column 3.  |
| <i>Step 7</i> | Col. 4                     | Determine the runoff coefficient C for the drainage area. Select a C value or compute a weighted C value based on area and cover type and record the value in Column 4.  |
| <i>Step 8</i> | Col. 5                     | Compute the time of concentration, $t_c$ , in minutes for the first inlet and record in Column 5. The $t_c$ is the time for the water to flow from the most hydraulically remote point of the drainage area to the inlet. The minimum time of concentration should be 5 minutes.   |
| <i>Step 9</i> | Col. 6                     | Using the $t_c$ , determine the rainfall intensity from the appropriate Intensity-Duration-Frequency (IDF) curve, for the design frequency. Enter the value in Column 6.   |

- Step 10* Col. 7 Calculate the flow in the gutter using  $Q = C_i A$ . The flow is calculated by multiplying Column 3  $\times$  Column 4  $\times$  Column 6. Enter the flow value in Column 7.
- Step 11* Col. 8 From the roadway profile, enter in Column 8 the gutter longitudinal slope,  $S_L$ , at the inlet, considering any superelevation.
- Step 12* Col. 9 From the cross section, enter the cross slope,  $S_x$ , in Column 9  
Col. 13 and the grate gutter width,  $W$ , in Column 13.
- Step 13* Col. 11 For the first inlet in a series, enter the value from Column 7 into  
Col. 10 Column 11 because there was no previous bypass flow. Additionally, if the inlet is the first in a series, enter 0 into Column 10.
- Step 14* Col. 14 Determine the spread  $T$ , enter the value in Column 14. Also,  
Col. 12 calculate the depth  $d$  at the curb by multiplying  $T$  times the cross slope(s) and enter in Column 12. Compare the calculated spread with the allowable spread as determined by the design criteria in [Section 12.7.3](#). Additionally, compare the depth at the curb with the actual curb height in Column 19. If the calculated spread, Column 14, is near the allowable spread and the depth at the curb is less than the actual curb height, continue on to Step 15. Otherwise, expand or decrease the drainage area up to the first inlet, to increase or decrease the spread, respectively. The drainage area can be expanded by increasing the length to the inlet, and it can be decreased by decreasing the distance to the inlet. Then, repeat Steps 6 through 14 until appropriate values are obtained.
- Step 15* Col. 15 Calculate  $W/T$  and enter in Column 15.
- Step 16* Col. 16 Select the inlet type and dimensions and enter in Column 16.
- Step 17* Col. 17 Calculate the flow intercepted by the inlet ( $Q_i$ ) and enter the value in Column 17. Use equations to define gutter flow and the flow intercepted by the inlet.
- Step 18* Col. 18 Determine the bypass flow,  $Q_b$ , and enter into Column 18.  $Q_b$  equals Column 11 minus Column 17.
- Step 19* Cols. Proceed to the next inlet downgrade. To begin the procedure,  
1-4 select a drainage area approximately 300 ft to 400 ft below the first inlet as a first trial. Repeat Steps 5 through 7 considering only the area between the inlets.

- 
- |                |                    |  |
|----------------|--------------------|--|
| <i>Step 20</i> | Col. 5             | Compute a time of concentration for the next inlet based upon the area between the consecutive inlets and record this value in Column 5.   |
| <i>Step 21</i> | Col. 6             | Determine the rainfall intensity from the IDF curve based upon the time of concentration determined in Step 20 and record the value in Column 6.                                   |
| <i>Step 22</i> | Col. 7             | Determine the flow in the gutter by multiplying Column 3 × Column 4 × Column 6. Enter the discharge in Column 7.   |
| <i>Step 23</i> | Col. 11            | Record the value from Column 18 of the previous line into Column 10 of the current line. Determine the total gutter flow by adding Column 7 and Column 10 and record in Column 11. |
| <i>Step 24</i> | Col. 12<br>Col. 14 | Determine the spread, T, and the depth at the curb as outlined in Step 14. Repeat Steps 18 through 24 until the spread and the depth at the curb are within the design criteria.   |
| <i>Step 25</i> | Col. 16            | Select the inlet type and dimensions and enter in Column 16.   |
| <i>Step 26</i> | Col. 17            | Determine the intercepted flow $Q_i$ in accordance with Step 17.   |
| <i>Step 27</i> | Col. 18            | Calculate the bypass flow by subtracting Column 17 from Column 11 and enter in Column 18. This completes the spacing design for this inlet.  |
| <i>Step 28</i> |                    | Repeat Step 19 through Step 27 for each subsequent inlet down to the low point.  |

An example problem that illustrates this procedure is provided in [HEC 22 \(Reference 1\)](#).

INLET SPACING COMPUTATION SHEET														ROUTE _____ of _____					
Date Computed By: _____ SP _____ Sheet _____ of _____																			
INLET		GUTTER DISCHARGE Design Frequency				GUTTER DISCHARGE Allowable Spread				GUTTER DISCHARGE				INLET DISCHARGE			REMARK		
		Drain. Area A ( ) (3)	Runoff Coeff. C. (4)	Time of Conc. $t_c$ (min) (5)	Rainfall Intens. $I$ (/hr) (6)	$Q = CIA/K_c$ ( <sup>3</sup> /s) (7)	$L_{max} S_c$ ( / ) (8)	Cross Slope $S_x$ or $S_w$ ( / ) (9)	Prev. Bypass Flow ( <sup>3</sup> /s) (10)	Total Gutter Flow ( <sup>3</sup> /s) (11)	Depth d ( ) (12)	Grate or Gutter Width ( ) (13)	Spread T ( ) (14)	W/T (15)	Inlet Type (16)	Intercept Flow $Q_i$ ( <sup>3</sup> /s) (17)		Bypass Flow $Q_b$ ( <sup>3</sup> /s) (18)	
(1)	(2)																	(19)	

Figure 12.10-E — INLET SPACING COMPUTATION SHEET



## 12.11 MANHOLES

### 12.11.1 Location

Manholes are used to provide entry to continuous underground storm drains for inspection and cleanout. Grate inlets can be used in lieu of manholes when entry to the system can be provided at the grate inlet, so that the benefit of extra stormwater interception can be achieved with minimal additional cost. Typical locations where manholes should be located are:

- where two or more storm drains converge,
- where cleanouts and/or inspections may be required, and
- where storm drain alignment or grade changes.

Manholes may be located at other locations where drop inlets/other structures could be used. Manholes should not be located in traffic lanes. However, where it is impossible to avoid locating a manhole in a traffic lane, ensure that it is not in the vehicular wheel path.

### 12.11.2 Spacing

The maximum spacing of manholes is as follows:

Size of Pipe (in)	Maximum Distance (ft)
≤ 48	300
> 48	600

### 12.11.3 Types

See the [SDDOT Standard Plates](#) for manhole lid types used by the Department. Their usage is as follows:

1. Type A Manhole Frame and Lid. SDDOT typically uses the Type A manhole.
2. Type C Manhole Frame and Lid. The Type C manhole is rarely used; it can be used to provide a 2 ft by 3 ft opening for equipment.
3. Type S Manhole Frame and Lid. SDDOT only uses the Type S manhole with the Type S drop inlet in locations that are not subject to traffic.

A manhole frame and lid provides entry to the below ground junction box. The junction can be rectangular or a precast circular section. In either case, the junction provides a location for the storm drain to change size, direction or grade.

### 12.11.4 **Sizing**

#### 12.11.4.1 **Rectangular Junction Box Minimum Size**

The outside diameter of all pipes entering the junction box should fit between the inside faces of the walls.

#### 12.11.4.2 **Circular Manhole Sizing Procedure**

SDDOT uses the following procedure to determine the size of precast circular manholes. A blank worksheet and software are available online; see ([Reference \(6\)](#)):

1. Assume a manhole size and determine a minimum leg angle (minimum  $L^\circ$ ) from Figure 12.11-A.

Manhole Size	Minimum L Angle
48 in	32°
60 in	29°
72 in	24°
84 in	24°
96 in	24°
120 in	24°

**Figure 12.11-A — MANHOLE SIZING BASED ON LEG ANGLE**

2. Determine the degrees required ( $A^\circ$ ) for each pipe opening from [Figure 12.11-B](#) for the assumed manhole size.
3. Find the leg angle ( $L^\circ$ ) between pipe openings.  $L^\circ = Y^\circ - 0.5 (A1^\circ + A2^\circ)$ . See [Figure 12.11-C](#).  $L^\circ$  must be larger than or equal to the minimum  $L^\circ$  given in [Figure 12.11-A](#).  $L^\circ \geq$  minimum  $L^\circ$ .
4. Use Figure 12.11-B and check the manhole height. The remaining full barrel height must be 1.3 ft minimum. See [Example 12.11-1](#) and the height considerations in the next paragraph.

This above sizing procedure is intended to be used only as a guide. The following should be considered:

Pipe Size (in)	"A" (degrees) Per Manhole Barrel Size						Blockout Height (ft)
	48 in	60 in	72 in	84 in	96 in	120 in	
<u>Round Pipe</u>							
12	52°	41°	34°	29°	26°	20°	1.7
15	60°	47°	39°	33°	29°	23°	2.0
18	72°	56°	46°	39°	34°	27°	2.3
24	94°	72°	59°	49°	43°	34°	2.9
30	122°	89°	72°	60°	52°	41°	3.5
36	*	110°	86°	72°	62°	48°	4.1
42		138°	102°	84°	72°	56°	4.7
48**		*	122°	97°	82°	64°	5.3
54**			153°	113°	94°	72°	5.8
60**			*	133°	107°	80°	6.4
<u>Arch Pipe</u>							
18	84°	65°	53°	45°	39°	31°	2.0
24	113°	84°	68°	57°	49°	39°	2.5
30	*	107°	84°	70°	60°	47°	3.0
36		*	105°	86°	73°	57°	3.4
42			129°	102°	85°	66°	3.8
48			*	124°	101°	76°	4.3
54				*	115°	85°	4.7
60**					140°	97°	5.2

\* Select a larger diameter manhole.

\*\* These sizes are too tall for a standard 6-ft manhole barrel section height. Check with the manufacturer for other possibilities (e.g., bends, tees).

**Figure 12.11-B — DEGREES REQUIRED FOR PIPE OPENING  
(For Round and Arch Pipe)**

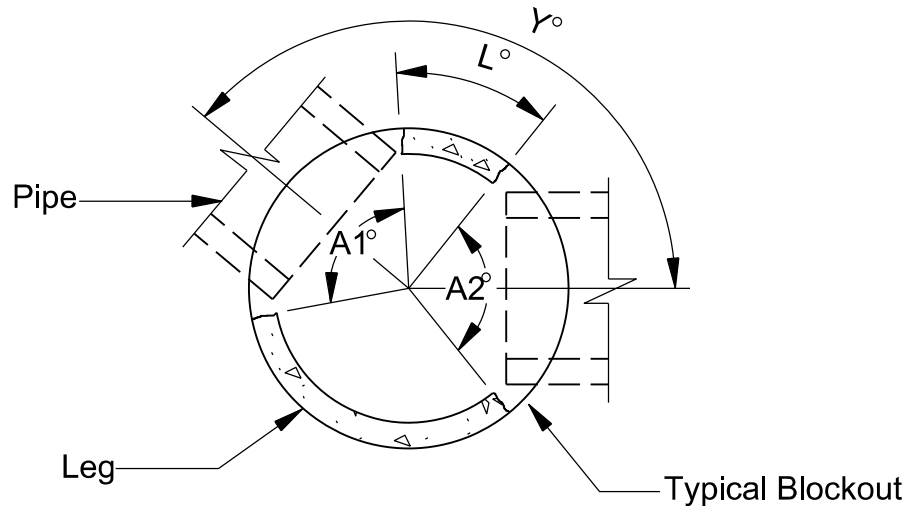

**Figure 12.11-C — TYPICAL PLAN SECTION**

1. **Scale Drawing.** A scale drawing should be prepared when deviating from these minimums. The blockout width must provide 3 in of clearance around the pipe, and the minimum leg angle ( $L^\circ$ ) must also be provided in the barrel.
2. **Height.** The remaining full barrel height in Step 4 of the sizing procedure can be less than the 1.3 ft minimum shown if the structure is made with a monolithic base slab.
3. **Size.** Smaller barrel sections may be possible if it is acceptable to offset the incoming pipe from centerline. For example, a 60-in manhole barrel would work in [Example 12.11-1](#) if the 18-in pipe could be moved closer to the 30-in pipe, thereby providing the minimum leg angle between the 18-in and 24-in pipe. The leg between the 18-in and 24-in pipe could also be eliminated by moving the two pipes closer together and using one large blockout for both. To make this work, the minimum leg angle ( $L^\circ$ ) must be provided in each 180 degrees such that the barrel can stand without tipping.
4. **Tee Sections/Bends.** Use manhole tee sections and bends for pipes larger than shown in [Figure 12.11-B](#).

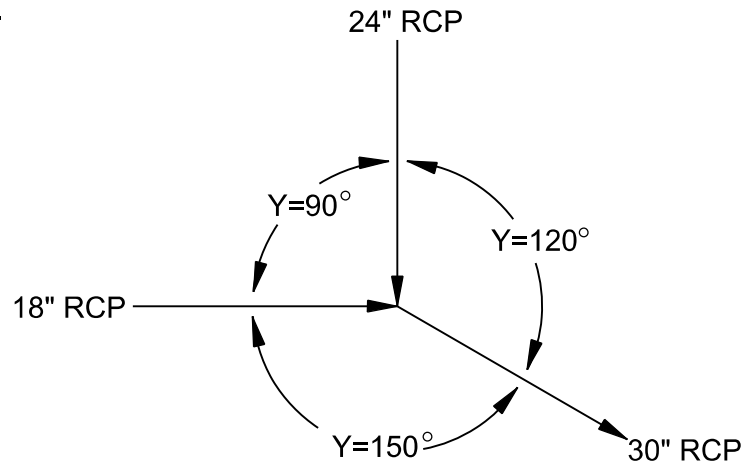
**Example 12.11-1**

**Given:** Use pipe layout above. Overall manhole height is 7.2 ft.

**Find:** Find smallest diameter and shortest manhole barrel that can accept the above pipe layout.

**Solution:**

**Step 1** Assume a manhole size and determine minimum  $L^\circ$  from [Figure 12.11-A](#):

Try a 60-in manhole. From [Figure 12.11-A](#), minimum  $L^\circ = 29^\circ$ .

**Step 2** Check  $L^\circ$  provided between each incoming leg against minimum  $L^\circ$ :

From [Figure 12.11-B](#):

60-in mh, 18-in to 30-in leg.  $L^\circ = 150^\circ - 0.5 (56^\circ + 89^\circ) = 77^\circ > 29^\circ$ ; ok

60-in mh, 18-in to 24-in leg.  $L^\circ = 90^\circ - 0.5 (56^\circ + 72^\circ) = 26^\circ < 29^\circ$ ; too small, try a larger manhole.

**Step 3** Try a 72-in manhole, minimum  $L^\circ = 24^\circ$ :

72-in mh, 18-in to 30-in leg.  $L^\circ = 150^\circ - 0.5 (46^\circ + 72^\circ) = 91^\circ > 24^\circ$ ; ok

72-in mh, 18-in to 24-in leg.  $L^\circ = 90^\circ - 0.5 (46^\circ + 59^\circ) = 37^\circ > 24^\circ$ ; ok

72-in mh, 24-in to 30-in leg.  $L^\circ = 120^\circ - 0.5 (59^\circ + 72^\circ) = 55^\circ > 24^\circ$ ; ok

**Step 4** Check the remaining full barrel height above the tallest blockout:

Overall manhole height including cover, casting, etc.:	7.2 ft
Less cover slab, 2-in grade ring and casting:	<u>-1.5 ft</u>
Net manhole barrel height:	5.7 ft
Less the tallest blockout height (Figure 12.11-B, 30-in RCP):	<u>-3.5 ft</u>
Remaining full barrel height above the blockouts:	<u>2.2 ft &gt; 1.3 ft; ok</u>

Answer: A 72-in manhole with an overall height of 7.2 ft will accept the above pipe layout.

## 12.12 INITIAL SIZING OF STORM DRAINAGE SYSTEM

### 12.12.1 Introduction

After the preliminary locations of inlets, connecting pipes and outfalls with tailwaters have been determined, the next step is the computation of the rate of discharge to be carried by each reach of the storm drain and the determination of the size and gradient of pipe required to convey this discharge. This is done by starting at the upstream reach, calculating the discharge and sizing the pipe, then proceeding downstream, reach by reach, to the point where the storm drainage system connects with other storm drains or the outfall.

The rate of discharge at any point in the storm drainage system is not necessarily the sum of the inlet flow rates of all inlets above that section of the storm drain. It is generally less than this total. The time of concentration is most influential and, as the time of concentration grows larger, the rainfall intensity to be used in the design grows smaller. In some cases, where a relatively large drainage area with a short time of concentration is added to the system, the peak flow may be larger using the shorter time even though the entire drainage area is not contributing. The prudent designer will be alert for unusual conditions and determine which time of concentration controls for each pipe segment. See [Section 12.5.4.2](#) for a discussion on time of concentration.

For ordinary conditions, storm drainage systems should be sized on the assumption that they will flow full or almost full under the design discharge but will not flow under pressure head. The Manning's formula is recommended for capacity calculations. The main storm drainage system should be designed by computing the hydraulic grade line and keeping the water surface elevations below the grates and/or established critical elevations for the design storm.

### 12.12.2 Design Procedures

The following procedures are used for the design of storm drainage systems:

*Step 1* Determine inlet location and spacing as outlined in [Section 12.10](#).

*Step 2* Prepare the plan layout of the storm drainage system establishing the following design data:

- location of storm drains;
- direction of flow;
- location of manholes/junction boxes (see [Section 12.11](#)); and

- location of existing utilities (e.g., water, gas, underground cables and existing and proposed foundations).
- Step 3* Determine drainage areas, runoff coefficients and a time of concentration to the first inlet. Using an Intensity-Duration-Frequency (IDF) curve, determine the rainfall intensity. Calculate the discharge with the Rational Method.
- Step 4* Size the pipe to convey the discharge by varying the slope and pipe size as necessary. The storm drainage systems are normally designed for full gravity-flow conditions using the design frequency discharges. Initial pipe size and slope can be estimated using the FHWA Hydraulic Toolbox, Channel Analysis, which contains both circular and rectangular sections. See [Figures 12.12-A](#) and [12.12-B](#), which provide full-flow curves for circular and arch pipes where  $n = 0.012$ .
- Step 5* Calculate travel time in the pipe to the next inlet or manhole by dividing pipe length by the velocity. This travel time is added to the time of concentration for a new time of concentration and a new rainfall intensity at the next entry point.
- Step 6* Calculate the new area ( $A$ ) and multiply by the runoff coefficient ( $C$ ), add to the previous ( $CA$ ) and multiply by the rainfall intensity ( $i$ ) to determine the discharge at this inlet. Determine the size of pipe and slope necessary to convey the discharge.
- Step 7* Continue this process to the storm drainage outlet.
- Step 8* Complete the design by calculating the hydraulic grade line as discussed in [Section 12.13](#).

Software is normally used to design and analyze storm drains. If the designer designs a storm drain with only a few links or wants to confirm the results of the software calculations, refer to the detailed design procedures and design example in [HEC 22 \(Reference \(1\)\)](#).

### 12.12.3 **Sag Point**

As discussed in [Section 12.5.2](#), the storm drain that drains a major sag point should be sized to accommodate the runoff from a 50-year frequency rainfall. This can be accomplished by computing the bypass occurring at the last inlet during a 50-year rainfall. The inlet at the sag point should be designed to accommodate this bypass, and the storm drainage pipe leading from the sag point should be sized to accommodate this additional bypass within the criteria established. To design the pipe leading from



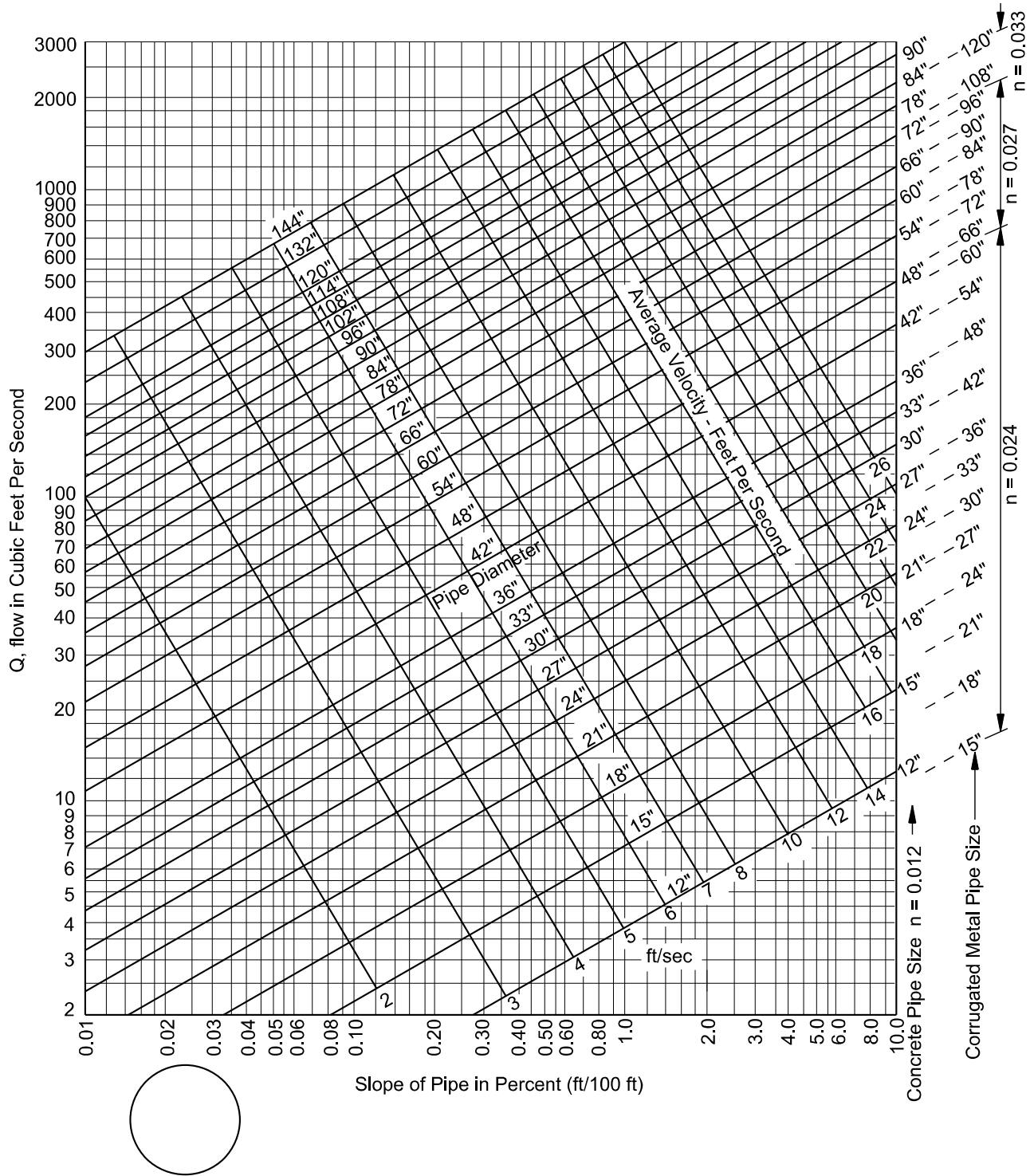

Figure 12.12-A — FULL-FLOW CURVES, CIRCULAR PIPE, n = 0.012

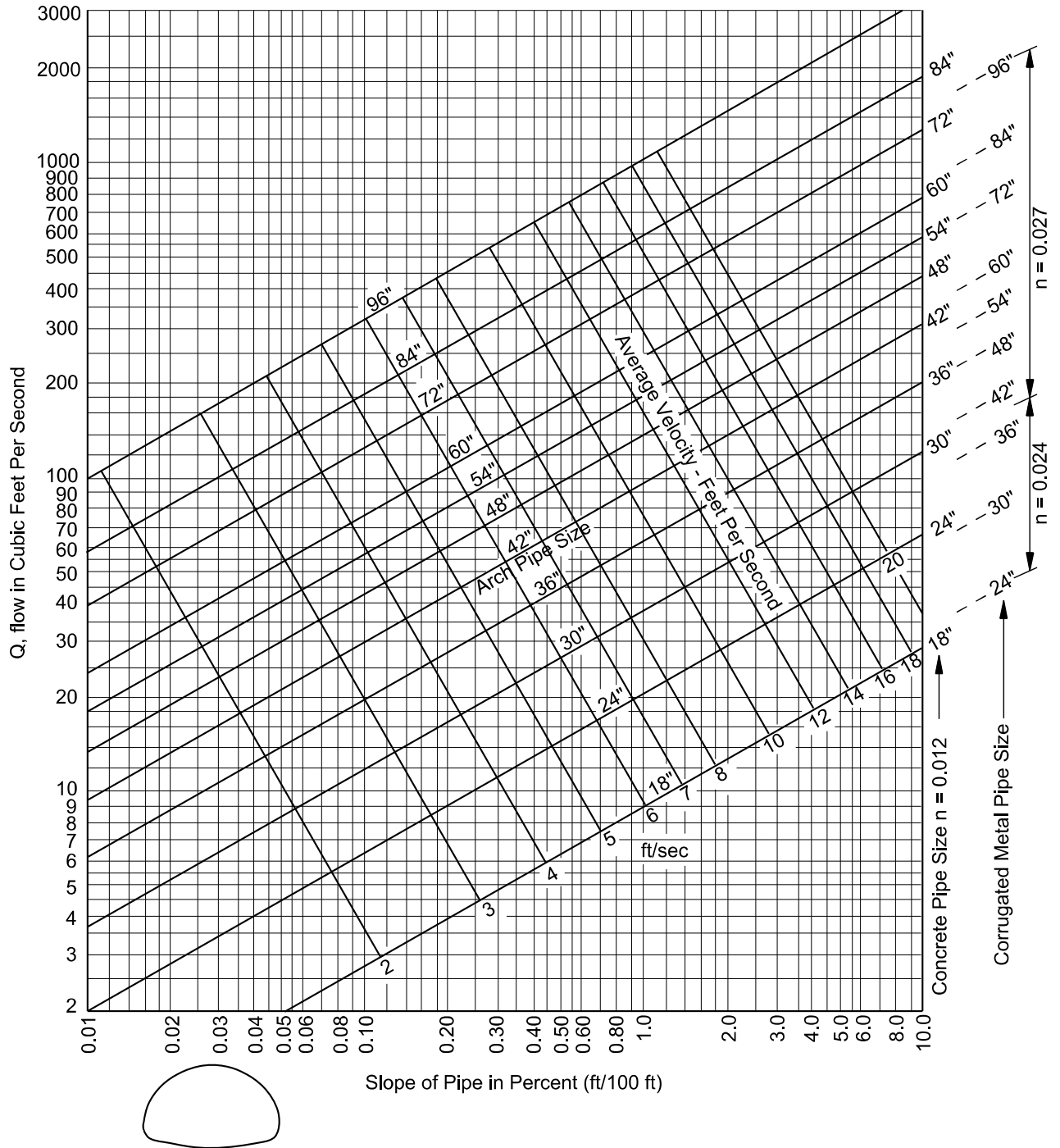

Figure 12.12-B — FULL-FLOW CURVES, ARCH PIPE,  $n = 0.012$

the sag point, it may be helpful to convert the additional bypass created by the 50-year rainfall into an equivalent CA that can be added to the design CA. This equivalent CA can be approximated by dividing the 10-year bypass by ( $i_{10}$ ) in the pipe at the sag point.

Some designers may want to design separate systems to prevent the above-ground system from draining into the depressed area. This concept may be more costly but, in some cases, may be justified. Another method would be to design the upstream system for a 50-year design to minimize the bypass to the sag point. Each case should be evaluated individually to assess the impacts and risk of flooding a sag point location.

#### **12.12.4 SDDOT Practices**

The following documents SDDOT practices (not related to the hydraulic analysis) for the underground portion of a storm drainage system.

##### **12.12.4.1 Minimum Pipe Size**

The typical minimum pipe size is 18 in. In special cases, a 12-in pipe may be used where it is not possible/practical to provide an 18-in pipe. Justification for a 12-in pipe should be documented. Pipe sizes increase in 3-in increments, although SDDOT normally uses 6-in increments for storm drainage pipes.

##### **12.12.4.2 Material**

SDDOT uses reinforced concrete pipes almost exclusive for storm drains. Corrugated metal pipe should be used for downspout outfalls from drop inlets in bridge approach slabs.

##### **12.12.4.3 Minimum Cover and Clearance**

A minimum cover of 1 ft should be provided between the top of pipe and the top of subgrade. A minimum clearance of 1 ft should be provided between storm drainage pipes and other underground facilities (e.g., sanitary sewers).

##### **12.12.4.4 Joint Seals**

Joints should have mastic seals where conditions warrant, such as:

- pressure flow,
- areas of rock or high water table, and/or
- as required by local ordinances.

Watertight joints are required for storm drainage pipes, drop inlets and manholes where storm drainage systems run parallel to and within 10 ft horizontally from existing or proposed water mains and where storm drainage systems cross water mains and are separated by a distance of 18 in or less, above or below, the water main.

If watertight joints are required, then the watertight joints should extend for a distance of 10 ft beyond the water main. This measurement should be from the sealed concrete joint to the outer most surface of the water main.

Watertight joint seals should conform to the following requirements:

1. Reinforced Concrete Pipe (Circular). Gasketed pipe should conform to the requirements of ASTM C443. Non-gasketed concrete pipe should be sealed with a mastic joint seal conforming to the requirements of ASTM C990 and encased with a minimum 2-ft wide by 6-in thick M6 concrete collar reinforced with 6 by 6 W2.9 by W2.9 wire mesh.
2. Reinforced Concrete Pipe (Arch). Joints should be sealed with a waterstop seal meeting the requirements of ASTM C990. Waterstop seals should consist of hydrophilic compounds (e.g., Waterstop-RX, ConSeal CS-231).
3. Drop Inlets, Manholes and Junction Boxes. Joints should be sealed with a waterstop seal or seal wrap meeting the requirements of ASTM C990 or encased with a minimum 2-ft wide by 6-in thick M6 concrete collar reinforced with 6 by 6 W2.9 by W2.9 wire mesh. Waterstop seal should contain hydrophilic compounds (e.g., Waterstop-RX, ConSeal CS-231). Seal wrap should be a self-adhesive external joint wrap (e.g., ConWrap CS-217, Mar Mac Seal Wrap).

#### **12.12.4.5 Pipe-to-Inlet Connections**

Pipes must connect with inlets on the flat side of the walls and not at the corners when the drop inlet is to be constructed using SDDOT standard plates. Pipe bends and/or a larger drop inlet may be needed for the pipe to fit into one of the sides of the inlet and to provide a connection away from the inlet corners. This prevents compromising the structural integrity of the drop inlet if the pipe is connected in or near the corner of a wall of the drop inlet.

#### **12.12.4.6 Storm Drainage Gradients**

Storm drainage pipe gradients should be approximately equal to the roadway grade. The same size of pipe will run until the cumulative discharge attains the pipe capacity. When an abrupt reduction in gradient is encountered, an increase of more than one pipe size larger may be required.

When increasing the size of pipe, two alternatives are available for design at the junction:

- align the pipe inverts (bottom of pipe) with a continuous flow line, or
- align the inside top of the pipe (soffit) with an abrupt drop in the flow line.

Each alternative has advantages and disadvantages. The hydraulic characteristics generally are better when the tops of the pipes are aligned. Also, this approach is better where there is a problem with minimum allowable cover over the pipes. In contrast, there may be situations in relatively flat terrain where it is necessary to conserve the elevation of the flow line. Under these conditions, it may be better to avoid the abrupt drops by aligning the pipe inverts at the junction.

Where gradients must be minimized, the flow lines of concrete arch pipe may be aligned more effectively than round pipe when the size is increased consecutively. If possible, a slight drop in the flow line is even preferred.

#### **12.12.4.7 Insulation**

Where there is minimal separation from water mains or individual service lines, it may be appropriate to insulate the water line to prevent damage from freezing conditions. Determination whether insulation is needed or not should be discussed with the local governing agency on a case by case basis based on separation distance and depth of waterline. Insulation is usually done by installing a rigid foam insulation barrier between the two utilities.

### 12.12.5 Hydraulic Analysis

#### 12.12.5.1 SDDOT Practices

The following SDDOT practices govern the hydraulic analysis of storm drainage systems:

1. Pipe Flow. The system should be designed for free surface flow. In difficult circumstances, it is acceptable to design for flowing full, either under pressure or not under pressure. The pipe can flow full at the check flow.
2. Minimum Velocity. The minimum allowable velocity is 2 fps. A lesser velocity may cause silting.
3. Maximum Velocity. The maximum velocity should be 10 fps. Where velocities exceed 10 fps, consider adding a drop inlet to include some of the elevation change at the inlet or consider energy dissipators.
4. Gradients. It is desirable to use a minimum gradient of 0.5% wherever possible. See [Section 12.12.6](#) for more discussion on minimum grades. The hydraulic gradeline will determine the maximum gradient.

#### 12.12.5.2 Methodology

SDDOT has adopted the hydraulic methodology in HEC 22 ([Reference \(1\)](#)) for the hydraulic analysis and design of a storm drainage system. HEC 22 c contains an example problem that illustrates the calculations for a simple system. For complex systems, software should be used for the analysis; see [Section 18.2.4](#).

The methodology for both gravity and pressure flow is Manning's formula, expressed by the following equation:

$$V = \frac{1.486}{n} R^{2/3} S^{1/2} \quad (\text{Equation 12.22})$$

where:

- V = mean velocity of flow, fps
- n = Manning's roughness coefficient
- R = hydraulic radius, ft = area of flow (A) divided by the wetted perimeter (WP)
- S = the slope of the hydraulic grade line, ft/ft

In terms of discharge, the above formula becomes:

$$Q = VA \frac{1.486}{n} AR^{2/3} S^{1/2} \quad (\text{Equation 12.23})$$

where:

Q = rate of flow, cfs  
 A = cross sectional area of flow, sq ft

For circular storm drains flowing full,  $R = D/4$  and Equations 12.22 and 12.23 become:

$$V = \frac{0.59}{n} D^{2/3} S^{1/2} \quad Q = \frac{0.46}{n} D^{8/3} S^{1/2} \quad (\text{Equation 12.24})$$

where:

D = diameter of pipe, ft

[HEC 22](#), Chapter 7 ([Reference \(1\)](#)) provides a comprehensive step-by-step procedure and worksheets for Storm Drain Design. A comprehensive example is provided that demonstrates the procedure.

### 12.12.6 Minimum Grades

All storm drainage systems should be designed such that velocities of flow will not be less than 3 fps at design flow. This criteria results in a velocity of 2 fps when the flow depth is 25% of the pipe diameter. For very flat grades, the general practice is to design components so that flow velocities will increase progressively throughout the length of the pipe system. The storm drainage system should be checked to ensure that there is sufficient velocity in all drains to deter settling of particles. Minimum slopes required for a velocity of 3 fps can be calculated by the Manning's formula (Equation 12.25), which was used to produce the values given in [Figure 12.12-C](#):

$$S = \left[ \frac{nV}{1.486 R^{2/3}} \right]^2 \quad (\text{Equation 12.25})$$

The channel calculator in the FHWA Hydraulic Toolbox can also be used.

### 12.12.7 Curved Alignment

Curved storm drains are permitted where necessary for 48-in or larger pipe using bend sections. Smaller pipes should not be designed with curves. Long-radius bend sections are available from many suppliers and are the preferred means of changing direction in pipes 48 in and larger. Short-radius bend sections are also available and can be used if there is not room for the long-radius bends. Deflecting the joints to obtain the necessary curvature is not desirable, except for very minor curvatures. Using large manholes solely for changing direction may not be cost effective on large-size storm drainage systems.

Pipe Size (in)	Full Pipe (cfs)	Minimum Slopes (ft/ft)		
		n = 0.012	n = 0.013	n = 0.024
8	1.1	0.0064	0.0075	0.0256
10	1.6	0.0048	0.0056	0.0190
12	2.4	0.0037	0.0044	0.0149
15	3.7	0.0028	0.0032	0.0111
18	5.3	0.0022	0.0026	0.0087
21	7.2	0.0018	0.0021	0.0071
24	9.4	0.0015	0.0017	0.0059
27	11.9	0.0013	0.0015	0.0051
30	14.7	0.0011	0.0013	0.0044
33	17.8	0.00097	0.0011	0.0039
36	21.2	0.00086	0.0010	0.0034
42	28.9	0.00070	0.00082	0.0028
48	37.7	0.00059	0.00069	0.0023
54	47.7	0.00050	0.00059	0.0020
60	58.9	0.00044	0.00051	0.0017
66	71.3	0.00038	0.00045	0.0015
72	84.8	0.00034	0.00040	0.0014

**Figure 12.12-C — MINIMUM SLOPES NECESSARY TO ENSURE 3 fps  
IN STORM DRAINS FLOWING FULL (Equation 12.25)**



## 12.13 HYDRAULIC GRADE LINE

### 12.13.1 Introduction

The hydraulic grade line (HGL) is the last important feature to be established for the hydraulic design of storm drainage systems. This grade line aids the designer in determining the acceptability of the proposed system by establishing the elevations along the system to which the water will rise when the system is operating at the design flood frequency; see [Figure 12.13-A](#).

In general, if the HGL is above the crown of the pipe, the pipe is in pressure flow. If the HGL is below the crown of the pipe, the pipe is in open channel flow. A special concern with storm drainage systems designed to operate under pressure-flow conditions is that inlet surcharging and possible manhole lid displacement can occur if the hydraulic grade line rises above the ground surface. A design based on open channel conditions should be carefully planned as well, including evaluation of the potential for excessive and inadvertent flooding created when a storm event larger than the design storm pressurizes the system. As hydraulic calculations are performed, frequent verification of the existence of the desired flow condition should be made. Storm drain systems can often alternate between pressure and open channel flow conditions from one section to another.

The detailed methodology employed in calculating the HGL through the system begins at the system outfall with the tailwater elevation. If the outfall is an existing storm drainage system, the HGL calculation should begin at the outlet end of the existing system and proceed upstream through this in-place system, then upstream through the proposed system to the upstream inlet. The same considerations apply to the outlet of a storm drain as to the outlet of a culvert. Usually, it is helpful to compute the energy grade line (EGL) first, then subtract the velocity head ( $V^2/2g$ ) to obtain the HGL. The software methods (see [Section 18.2.4](#)), which are based on energy loss, follow this practice.

### 12.13.2 SDDOT HGL Practices

The hydraulic grade line should be computed for all storm drainage systems including a determination of the outfall tailwater condition. The following practices should be done where possible when designing a storm drainage system:

- the slope and the pipe sizes are chosen so that the slope is equal to or greater than the friction slope,
- the top surfaces of successive pipes are aligned at changes in size (rather than flow lines being aligned), and

- the surface of the water at the point of discharge does not rise above the top of the outlet.

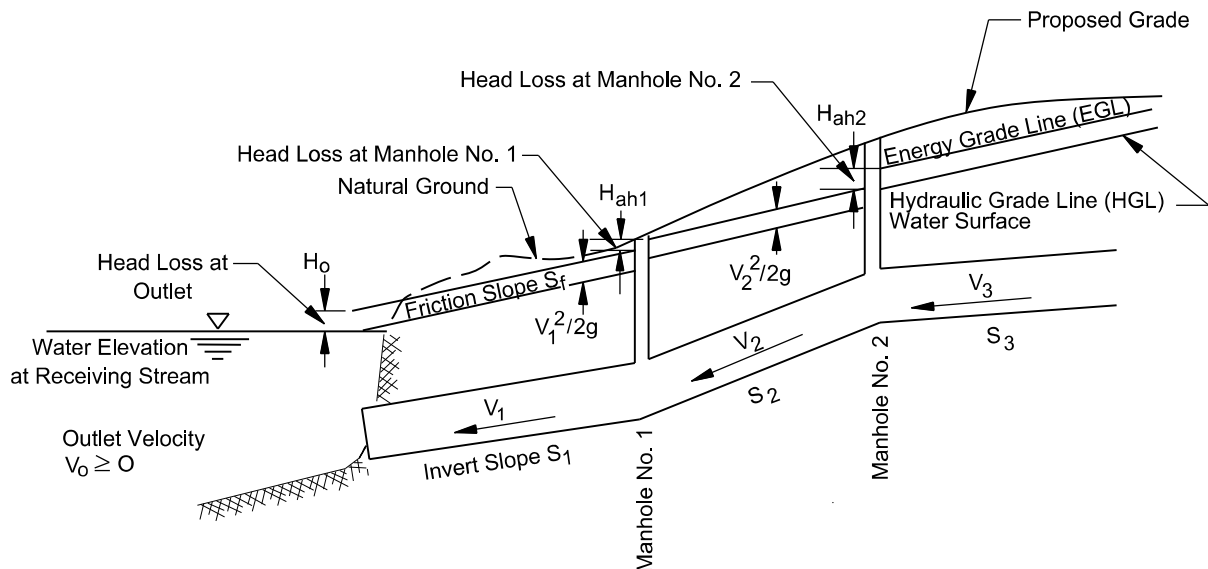

**Figure 12.13-A — HYDRAULIC AND ENERGY GRADE LINE ILLUSTRATION**

The pipe will not operate under pressure in these cases, and the slope of the water surface under capacity discharge will approximately parallel the slope of the pipe invert.

Hydraulic gradeline computations should begin with the tailwater elevation at the storm drainage outfall and progress upward through the entire length of the storm drainage. For every run, compute the friction loss and plot the elevation of the total head at each manhole and inlet.

SDDOT has adopted the methodology in HEC 22 ([Reference \(1\)](#)) for the calculation of the energy losses for a storm drainage system. The remainder of [Section 12.13](#) summarizes the necessary equations for calculating the HGL. See [HEC 22](#) Chapter 7 ([Reference \(1\)](#)) for symbol definitions, design procedures, computation sheets and an example calculation. See [Section 18.2.4](#) for SDDOT's adopted software for the storm drainage analysis, which includes the HGL.

If the hydraulic grade line does not rise above the top of any manhole or above an inlet entrance, the storm drainage system is satisfactory. If the HGL rises above these points, blowouts will occur through manholes and inlets. Pipe sizes or gradients can be increased as necessary to eliminate such blowouts. SDDOT practice is to ensure that the HGL is a minimum of 12 in below the top of the inlet for the design discharge.

### 12.13.3 Tailwater

For most design applications, the tailwater will either be above the crown of the outlet or can be considered to be between the crown and critical depth. To determine the EGL, begin with either the tailwater elevation or  $(d_c + D)/2$ , whichever is higher, add the velocity head for full flow and proceed upstream to adding appropriate losses (e.g., exit, friction, junction, bend, entrance).

An exception to the above procedure is an outfall with low tailwater. In this case, a water surface profile calculation would be appropriate to determine the location where the water surface will either intersect the top or end of the barrel and full-flow calculations can begin. In this case, the downstream water surface elevation would be based on critical depth or the tailwater, whichever is higher.

### 12.13.4 Energy Losses

Prior to computing the hydraulic grade line, all energy losses in pipe runs and junctions must be estimated. In addition to the principal energy involved in overcoming the friction in each conduit run, energy (or head) is required to overcome changes in momentum or turbulence at outlets, inlets, bends, transitions, junctions and manholes. The following sections present relationships for estimating typical energy losses in storm drainage systems. The application of some of these relationships is included in the design example in [HEC 22](#), Section 7.6 ([Reference \(1\)](#)).

#### 12.13.4.1 Exit Losses

The exit loss is a function of the change in velocity at the outlet of the pipe. For a sudden expansion, such as an endwall, the exit loss is:

$$H_o = C_o \left[ \frac{V^2}{2g} - \frac{V_d^2}{2g} \right] \quad \text{(Equation 12.26)}$$

where:

- V = average outlet velocity, fps
- $V_d$  = channel velocity downstream of outlet, fps
- $C_o$  = exit loss coefficient = 1.0

Note that, when  $V_d = 0$  as in a reservoir, the exit loss is one velocity head. For partial full flow where the pipe outlets into a channel with moving water, the exit loss may be reduced to virtually zero.

### 12.13.4.2 Pipe Friction Losses

The friction slope is the energy gradient in ft/ft for that run. The friction loss is simply the energy gradient multiplied by the length of the run in feet. Energy losses from pipe friction may be determined by rewriting Manning's Equation with terms as previously defined:

$$S_f = [Qn / 1.486 AR^{2/3}]^2 \quad (\text{Equation 12.27})$$

The head losses due to friction may be determined by the formula:

$$H_f = S_f L \quad (\text{Equation 12.28})$$

Manning's Equation can also be written to determine friction losses for storm drains as follows:

$$H_f = \left( \frac{Qn}{0.46D^{2.67}} \right)^2 \quad (\text{circular shapes}) \quad (\text{Equation 12.29})$$

$$H_f = \frac{29 n^2 L}{R^{4/3}} \left( \frac{V^2}{2g} \right) \quad (\text{see } \text{Section 10.4.5.6}) \quad (\text{Equation 12.30})$$

where:

- $H_f$  = total head loss due to friction, ft
- $n$  = Manning's roughness coefficient
- $D$  = diameter of pipe, ft
- $L$  = length of pipe, ft
- $V$  = mean velocity, fps
- $R$  = hydraulic radius, ft
- $g$  = 32.2 ft/sec<sup>2</sup>
- $S_f$  = slope of hydraulic grade line, ft/ft

### 12.13.4.3 Bend Losses

The bend loss coefficient for storm drainage system design is minor but can be evaluated using the formula:

$$h_b = 0.0033 (\Delta) (V_o^2 / 2g) \quad (\text{Equation 12.31})$$

where:

- $\Delta$  = angle of curvature, degrees

#### 12.13.4.4 Manhole/Inlet Losses Inlet

The head loss encountered from one pipe to another through a manhole is commonly represented as being proportional to the velocity head at the outlet pipe. Using  $K_M$  to signify this constant of proportionality, the energy loss is:

$$H_M = K_M \left( \frac{V^2}{2g} \right) \quad (\text{Equation 12.32})$$

For simple systems, an estimate or approximation of the  $K_M$  value can be used. For complex systems with complicated junctions, the  $K_M$  value should be determined using the [HEC 22 \(Reference \(1\)\)](#) method.

##### 12.13.4.4.1 Manhole Loss Estimate

The approximate method for computing losses at manholes involves multiplying the velocity head of the outflow pipe by a coefficient as represented in Equation 12.32. [Figure 12.13-B](#) presents applicable coefficients for  $K_M$ . This method can be used to estimate the initial pipe crown drop across a manhole or drop inlet to offset energy losses at the structure.

Structure Configuration	$K_M$
Inlet – Straight Run	0.50
Inlet – Angled Through:	
90°	1.50
60°	1.25
45°	1.10
22.5°	0.70
Manhole – Straight Run	0.15
Manhole – Angled Through:	
90°	1.00
60°	0.85
45°	0.75
22.5°	0.45

**Figure 12.13-B —  $K_M$  BASED ON STRUCTURE CONFIGURATION**

## 12.13.4.4.2 Manhole Losses (HEC 22 Method)

HEC 22 ([Reference \(1\)](#)), (2001 edition) contains a detailed loss-calculation method, which is included as an option in most storm drainage design software:

$$K_M = K_o C_D C_d C_Q C_p C_B \quad (\text{Equation 12.33})$$

where:

- $K_M$  = adjusted loss coefficient
- $K_o$  = initial head loss coefficient based on relative manhole size
- $C_D$  = correction factor for pipe diameter (pressure flow only)
- $C_d$  = correction factor for flow depth (non-pressure flow only)
- $C_Q$  = correction factor for relative flow
- $C_p$  = correction factor for plunging flow
- $C_B$  = correction factor for benching

The equations for calculating the above correction factors are found in HEC 22 (2001). FHWA has improved the above method and published the following method in HEC 22 (2009). The method involves three fundamental steps (with terms as defined in Figure 12.13-C):

- Step 1** Determine an initial manhole energy level ( $E_{ai}$ ) based on inlet control (weir and orifice) or outlet control (partial and full flow) equations.
- Step 2** Adjust the initial manhole energy level based on benching, inflow angle(s), and plunging flows to compute the final calculated energy level ( $E_a$ ).
- Step 3** Calculate the exit loss from each inflow pipe and estimate the energy gradeline (EGL), which will then be used to continue calculations upstream.

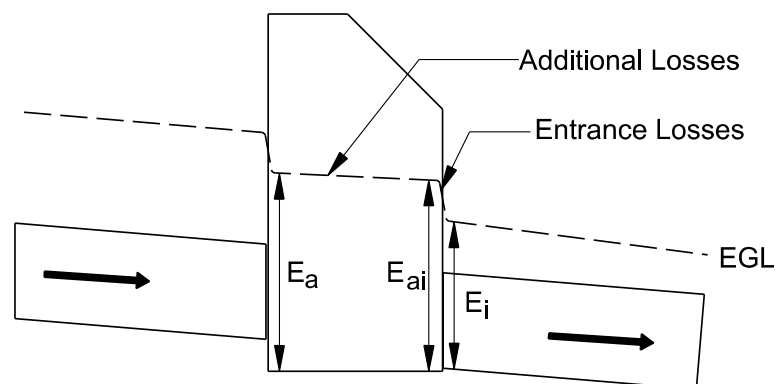

**Figure 12.13-C — DEFINITION SKETCH FOR HEC 22 (2009) MANHOLE LOSS METHOD**

### **12.13.5 Hydraulic Grade Line Design Procedure**

The equations and charts necessary to manually calculate the location of the hydraulic grade line are included in [HEC 22 \(Reference \(1\)\)](#) and are illustrated with an example problem. HEC 22 contains a computation form that permits the use of the approximate  $K_M$  and an additional form for documenting the HEC 22 (2009) loss method.

## 12.14 URBAN WATER QUALITY PRACTICES

The purpose of an urban Best Management Practice (BMP) is to mitigate the adverse impacts of development activity. BMPs can be employed for stormwater control benefits and/or pollutant removal capabilities. Several BMP options are available and should be carefully considered based on site-specific conditions and the overall management objectives of the watershed. Regulatory control for water quality practices are driven by National Pollution Discharge Elimination System (NPDES) requirements under such programs as the *Clean Water Act*. See [Chapter 2 “Legal Aspects”](#) and [Chapter 17 “Permits/Certifications”](#). Water quality practices may not be required depending on local ordinances and regulations in specific project locations. [HEC 22 \(Reference \(1\)\)](#), Chapter 10 provides a brief introduction to the types of BMPs that have been historically used to provide water quality benefits.



## 12.15 INVERTED SIPHONS

An inverted siphon carries the flow under an obstruction such as sanitary sewers, water mains or any other structure or utility line that is in the path of the storm drain line. The storm drain invert is lowered at the obstacle and is raised again after the crossing. A minimum of two barrels with 3 fps velocity is recommended. The inlet and outlet structures should be designed by keeping the normal flow in one barrel to provide the required minimum velocity for self-cleaning and servicing.

The following considerations from HEC 22 ([Reference \(1\)](#)) are important to the efficient design of siphons:

- Self-flushing velocities should be provided under a wide range of flows.
- Hydraulic losses should be minimized.
- Provisions for cleaning should be provided.
- Sharp bends should be avoided.
- The rising portion of the siphon should not be too steep as to make it difficult to flush deposits (some agencies limit the rising slope to 15%).
- There should be no change in pipe diameter along the length of the siphon.
- Provisions for drainage should be considered.

Additional information related to the design of siphons is provided in [USBR Design of Small Canal Structures \(Reference \(7\)\)](#), which includes a design example.

SDDOT does not recommend the use of inverted siphons. If an inverted siphon is proposed, the design must be reviewed by the SDDOT Bridge Hydraulic Engineer and approved by the SDDOT Chief Road Design Engineer and the owner of the waterway.

## 12.16 REFERENCES

- (1) FHWA, [\*Urban Drainage Design Manual, Third Edition\*](#), Hydraulic Engineering Circular No. 22, FHWA-NHI-10-009, Federal Highway Administration, US Department of Transportation, Washington DC, 2009.
- (2) AASHTO, [\*Highway Drainage Guidelines, 4<sup>th</sup> Edition\*](#), Chapter 9 “Storm Drainage Systems,” American Association of State Highway and Transportation Officials, Washington DC, 2005.
- (3) South Dakota Department of Transportation, [\*South Dakota Road Design Manual\*](#).
- (4) AASHTO, [\*A Policy on Geometric Design of Highways and Streets\*](#), Task Force on Geometric Design, 5<sup>th</sup> Edition, American Association of State Highway and Transportation Officials, Washington DC, 2004.
- (5) FHWA, [\*Design Charts for Open Channel Flow\*](#), Hydraulic Design Series No. 3, FHWA-EPD-86-102, FHWA, 1961.
- (6) [\*“Manhole Sizing Procedure”\*](#), Cretex Concrete Products West, 2004.
- (7) US Bureau of Reclamation, [\*Design of Small Canal Structures\*](#), Denver, CO, 1960, 1978.

